

394 MODEL



Annotating Circular Recorder Specification Sheet

- **Up to 6 universal inputs**
- **Modbus communications**
- **Annotation**
- **PID control**

The 394 is a clear step forward in circular trending technology. The optional MODBUS RTU protocol ensures compatibility with standard SCADA software and other industrial instrumentation. Four colour printing together with annotation produces a clear and easy to read chart including printed text of channel values, time, date, scales and totaliser values. The unit is fully configurable from the front panel or via the optional PC card reader. Up to two PID controllers can be added enabling the 394 to control as well as record the process. A host of software and hardware options allows the 394 to exactly fit the requirements of your application.

| | |
|---------------------------------|---|
| Available features |  |
| | 394 |
| Display | Digital |
| Channels | Up to 6 |
| Relays | Up to 18 |
| Annotation | Standard |
| Chart diameter | 10" |
| Retransmission | Up to 4 |
| Modbus communications | Modbus RTU slave, EIA485 |
| Memory card | PCMCIA Type I (SRAM) |
| Math | 16 channels |
| PC Configuration | Configuration Editor |
| Transmitter power supply | Up to 6 channels |
| PID Control | Up to 2 |

Input technology

Use of the very latest in Application Specific Integrated Circuit (ASIC) and Surface Mount technologies, gives the 394 input circuitry high accuracy and stability. Inputs are fully universal accepting signals from thermocouples, resistance thermometers, potentiometers and digital sources, as well as linear dc voltage and current sources.

Annotation

The use of a multi-point printhead provides the 394 with the ability to print text on the chart including channel values, time, date, scales and totaliser values.

Display

The 394 display consists of a 20-character vacuum fluorescent display and alarm indicators.

Control

Two independent controllers can be case mounted to provide PID control of related process variables.

Configuration

The recorder is fully configurable from the front panel using push-button keys to follow a series of text prompts at the display. Access to most functions can be password protected as a part of the configuration process.

The recorder can also be configured from a PC based package, allowing the user to set up the configuration off-site for later downloading to the recorder.

PC-Card Storage

Using the computer industry standard type 1 SRAM PC-card, the recorder's configuration can be stored for transfer to another recorder or to a PC for manipulation using the PC configuration tool. Process data can also be stored on the PC-card in a format readable by standard spreadsheet packages, or, alternatively in a compressed format that can be used with the Eurotherm Review Software, a Windows based package for viewing and printing charts.

Maths, Timers, Counters and Totalisers

These options provide the recorder with integrating and counting facilities, and the ability to carry out calculations ranging from simple arithmetic functions (e.g. subtracting one channel's value from another) to complex application specific functions such as Mass Flow calculations.

MODBUS Communications

The communications option uses the MODBUS RTU protocol to ensure compatibility with standard SCADA software and other types of industrial equipment such as PLCs (the 394 acts as a slave device). The EIA485 specification allows multiple instruments on a single communications link.

Relay Outputs

Up to 18 relay outputs can be fitted, driven by any internal recorder event such as channel alarm, totaliser overflow, totaliser output etc.

Analogue Outputs

Up to four of the input or maths channels can be output as a linearised current or voltage signal.

Transmitter Power Supply

Up to six current loops can be powered by a built-in 25 Volt dc power supply unit which is suitable for most loops.

SPECIFICATION

Recorder

Board types and hardware options

Standard: Universal input / control board
Options: Changeover relay output board
Analogue output board
Communications board
Transmitter Power Supply
PID controller
PC Card

Environmental performance

Temperature limits Operation: 0 to 50°C (options can reduce maximum temp.)
Storage: -20 to +70°C

Humidity limits

(non-condensing): 10 to 90%

Protection: Standard: NEMA3 (IP54)

Waterproof: NEMA4 (IP65)

Shock: BS EN60873 and BS EN61010

Vibration (BS EN60873): 1g peak at 60 Hz to 150Hz

Altitude (max.): <2000 metres

Electromagnetic compatibility (EMC)

Emissions: BS EN50081-2

Immunity: BS EN50082-2

Electrical safety (BS EN61010)

Installation cat. II; Pollution degree 2

Physical

Bezel size: 360mm H x 380mm (When viewed from the front, offset 5mm right with respect to cutout centreline).

Panel cutout dimensions: 340.5mm H x 345mm W (both - 0 + 1 mm)

Depth behind bezel rear face: 150 mm

Weight: 7 kg (typical)

Panel mounting: +5 to -30 degrees from vertical (+ = top overhangs)

Printing system

Pen type: Four colour cartridge

Trace resolution Lateral: 0.2 mm
Time: 0.36mm at outer edge of chart

Default trace colours: See table 5

Printhead life Channel: 1.5 x 10⁶ dots black
1.0 x 10⁶ dots (other colours)

Update rate: 2 Hz (1 Hz for complex configurations)

Print rate (max): 1 pass every 5 seconds

Text characters per line: 39

| Channel | Colour | Channel | Colour |
|---------|--------|---------|-------------|
| 1 | blue | 4 | black |
| 2 | red | 5 | blue/red |
| 3 | green | 6 | green/black |

Table 5 Trace colours

Paper transport

Type: Stepper motor

Chart type: Circular

Chart speeds Menu selectable: 12, 24, 48, 72 hours or 7 days/rev.

User enterable: 1 to 960 hours/rev

Power requirements

Line voltage Standard: 90 to 264V at 45 to 65 Hz.

Low voltage option: 20 to 53 V ac/dc
(ac frequency range: 45 to 400 Hz)

Power requirements (continued)

| | |
|----------------------|--|
| Power (Max): | < 100 VA (20VA typical) |
| Fuse type: | Not user servicable |
| Interrupt protection | Standard: 40 ms at 75% max. instrument load |
| | Enhanced: 120 ms at 75% max. instrument load |

Options

Serial Communications

| | |
|-------------|--|
| Type: | EIA 485 MODBUS® RTU |
| Isolation†: | Terminals to ground 100V RMS/dc (basic insulation) |

Maths pack

| | |
|--|--|
| Number of derived channels: | 16 |
| Level 1 functions: | Off, constant, add, subtract, multiply, divide, modulus. |
| Level 2 functions (additional to level 1): | See table 6 |

| | | | |
|------------------------|--------------------------|-----------------------|----------------|
| Channel average | DV group continuous min. | Sample and hold | Zirconia probe |
| Channel minimum | DV group latching max. | Square root | High select |
| Channel maximum | DV group continuous max. | 3rd order polynomial | Low select |
| Rolling average | e_x | Fvalue | Switch |
| Rate of change | \log_n | Relative humidity | Stopwatch |
| DV group average | 10_x | Linear mass flow | Time stamp |
| DV group latching min. | \log_{10} | Square root mass flow | O2 correction |
| | | | Percentile |

Table 6 Level two maths functions

Customer linearisation tables

| | |
|-------------------------|-----|
| N° of tables available: | One |
| N° of point pairs : | 32 |

Relay outputs

| | |
|----------------------------|--|
| Maximum switching power*: | 500VA or 60W |
| Maximum breaking current*: | 2 Amps within above power ratings |
| Maximum contact voltage*: | 250V within above power ratings |
| Isolation† | Contact to contact: 300V RMS or dc (double insulation) |
| | Contact to ground: 300V RMS or dc (basic insulation) |

Estimated life with resistive loads*:

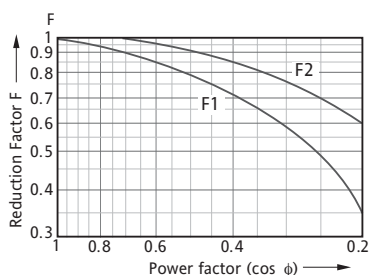

* With inductive loads, derate according to the graph, in which: contact life = resistive life x F1 or F2 where F1 = measured on representative examples and F2 = typical values according to experience.

Analogue (retransmission) outputs

| | |
|-----------------------------------|--|
| Output ranges (user configurable) | |
| | Voltage: 0 to 10V (Source 6.3mA max.) |
| | Current: 0 to 20mA (max. voltage drop = 18V) |
| Update rate: | 1Hz |
| Step response 910% to 90%: | 250msec |
| Linearity (maximum error): | 0.02% of hardware range |
| Performance: | See table 7 |
| Isolation† | Channel to channel: 300V RMS or dc (double insulation) |
| | Channel to ground: 300V RMS or dc (basic insulation) |

| Range | | Error at 20 °C | Temperature coefficient (per °C) |
|-----------|---------|--------------------------------|--------------------------------------|
| 0 to 10 V | Typical | 5.7mV + 0.08% of output | 100 μ V/°C + 50ppm/°C of output |
| | Max | 11.7mV + 0.18% of output | 300 μ V/°C + 70ppm/°C of output |
| 0 to 20mA | Typical | 15.3 μ A + 0.11% of output | 0.2 μ A/°C + 50 ppm/°C of output |
| | Max | 30.5 μ A + 0.21% of output | 1 μ A/°C + 80 ppm/°C of output |

Table 7 Analogue output performance

Transmitter Power Supply

| | |
|-----------------|--|
| Output voltage: | 3 or 6 x 25Vdc (nom) outputs |
| Isolation† | Channel to channel: 100V RMS or dc (double insulation) |
| | Channel to ground: 100V RMS or dc (basic insulation) |

Controllers

| | |
|---------|---|
| Number: | Up to 2 |
| Type: | Eurotherm type 2216 PID temperature controllers |

Input board

General

| |
|---|
| INSTALLATION CATEGORY II |
| The rated impulse voltage for equipment on nominal 230V mains is 2300V. |
| POLLUTION DEGREE 2 |
| Normally, only non-conductive pollution occurs. Occasionally, however, a temporary conductivity caused by condensation shall be expected. |

| | |
|---------------------------|---|
| Input types: | dc Volts, dc millivolts, dc milliamps (with shunt) |
| | Thermocouple, 2 / 3-wire RTD |
| | Contact closure (not channel 1) >500ms |
| Input type mix: | Freely configurable |
| Maximum number of inputs: | 6 |
| Input ranges: | -38 to +38mV; -150 to +150mV; -1V to +1V; -10 to +10mV |

| | |
|------------------------------|--|
| Termination: | Terminal block |
| Noise rejection (48 to 62Hz) | Common mode: >130dB (channel to channel and channel to ground) |
| | Series mode: 60dB |

| | |
|------------------------------|---|
| Maximum common mode voltage: | 250 Volts continuous |
| Maximum series mode voltage: | 45mV at lowest range; 12 Volts peak at highest range |

| | |
|------------------------------------|--|
| Isolation (dc to 65Hz; BS EN1010): | Installation cat. II; pollution degree 2 |
|------------------------------------|--|

| | |
|---------------------------------|------------------------------------|
| Channel-to-channel electronics: | 300V RMS or dc (double insulation) |
| Channel-to-common electronics: | 300V RMS or dc (double insulation) |
| Channel-to-ground: | 300V RMS or dc (basic insulation) |

Eielectric strength (BS EN61010): (1 minute type tests.)

| | |
|---------------------|----------|
| Channel to channel: | 2300 Vac |
| Channel to ground: | 1350 Vac |

Insulation resistance: >10 m Ω at 500 Vdc

| | |
|-------------------|-----------------------------|
| Input resistance: | 38mV, 150mV |
| | 1V ranges: >10 M Ω ; |
| | 10V range: 68.8k Ω |

Over voltage protection (max): 42V RMS (between I and V-); 50V RMS (I and V+) or (V+ and V-)

| | |
|-------------------------------|------------------|
| Open circuit detection drive: | \pm 57 nA max. |
| Recognition time: | 500 msec |
| Minimum break resistance: | 10 M Ω |

DC Input ranges

| | |
|--------------------------------|-------------------------------------|
| Stunt/Attenuator: | Internally mounted resistor modules |
| Additional error due to shunt: | 0.1% of input |

Additional error due to attenuator: 0.2% of input

| | |
|-----------------------|-------------------|
| Leakage current (max) | 38mV range: 1.7nA |
| | Other ranges: 8nA |

Performance: See table 1

| Range | Resolution | Error at 20 °C | | Temperature coefficient (per °C) |
|----------|------------|----------------|-----------------------------|----------------------------------|
| ± 38 mV | 1.4 µV | Typical | 0.035% input + 0.030% range | 37 ppm input + 1.03 ppm range |
| | | Max | 0.085% input + 0.051% range | 80 ppm input + 18.6 ppm range |
| ± 150 mV | 5.5 µV | Typical | 0.035% input + 0.027% range | 35 ppm input + 0.52 ppm range |
| | | Max | 0.084% input + 0.038% range | 80 ppm input + 7.8 ppm range |
| ± 1 V | 37 µV | Typical | 0.035% input + 0.024% range | 35 ppm input + 0.16 ppm range |
| | | Max | 0.084% input + 0.029% range | 80 ppm input + 1.6 ppm range |
| ± 10 V | 370 µV | Typical | 0.076% input + 0.024% range | 76 ppm input + 0.35 ppm range |
| | | Max | 0.275% input + 0.030% range | 272 ppm input + 3.5 ppm range |

Table 1 DC performance

Thermocouple data

Temperature scale: ITS 90
 Bias current (maximum): 1.7 nA
 Cold junction types: Off, internal, external, remote
 CJ error: 1°C max; instrument at 20°C
 CJ rejection ratio: 50:1 minimum
 Remote CJ: Via any user-defined channel
 Upscale / downscale drive: High. Low or None selectable for each thermocouple channel. Channels can be any max of high and none or Low and none, but High and low cannot be mixed.
 Types and ranges: See table 2

| TC Type | Overall range (°C) | Standard | Max linearisation error |
|----------|--------------------|----------------------------|--|
| B | 0 to +1820 | IEC 584.1 | 0 to 400°C: 1.7°C 400 to 1820°C: 0.03°C |
| C | 0 to +2300 | Hoskins | 0.12°C |
| D | 0 to +2495 | Hoskins | 0.08°C |
| E | -270 to +1000 | IEC 584.1 | 0.03°C |
| G2 | 0 to +2315 | Hoskins | 0.07°C |
| J | -210 to +1200 | IEC 584.1 | 0.02°C |
| K | -270 to +1372 | IEC 584.1 | 0.04°C |
| L | -200 to +900 | DIN 43700:1985 (To IPTS68) | 0.20°C |
| N | -270 to +1300 | IEC 584.1 | 0.04°C |
| R | -50 to +1768 | IEC 584.1 | 0.04°C |
| S | -50 to +1768 | IEC 584.1 | 0.04°C |
| T | -270 to +400 | IEC 584.1 | 0.02°C |
| U | -200 to +600 | DIN 43710:1985 | 0.08°C |
| Ni/NiMo | 0 to +1406 | Ipsen | 0.14°C |
| Platinel | 0 to +1370 | Ingelhard | 0.02°C |

Table 2 Thermocouple types and ranges

Resistance inputs

Temperature scale: ITS 90
 Ranges (including lead resistance): 0 to 150Ω, 0 to 600Ω, 0 to 6kΩ
 Influence of lead resistance Error: Negligible (3-wire connection)
 Mismatch: 1Ω/Ω
 Wetting current: 250µA typical
 Resolution and accuracy: See table 3
 RTD types and ranges: See table 4

| Range (Ω) | Resolution | Error at 20 °C | | Temperature coefficient (per °C) |
|-----------|------------|----------------|-----------------------------|----------------------------------|
| 0 to 150 | 5mΩ | Typical | 0.030% input + 0.047% range | 20 ppm input + 2.04 ppm range |
| | | Max | 0.045% input + 0.141% range | 35 ppm input + 36.6 ppm range |
| 0 to 600 | 22mΩ | Typical | 0.030% input + 0.036% range | 20 ppm input + 0.97 ppm range |
| | | Max | 0.045% input + 0.069% range | 35 ppm input + 14.6 ppm range |
| 0 to 6k | 148mΩ | Typical | 0.034% input + 0.026% range | 20 ppm input + 0.19 ppm range |
| | | Max | 0.049% input + 0.032% range | 35 ppm input + 1.9 ppm range |

Table 3 Resistance ranges resolution and accuracy

| RTD Type | Overall range (°C) | Standard | Max linearisation error |
|----------|--------------------|------------------------|-------------------------|
| Cu10 | -20 to + 400 | General Electric Co. | 0.02 °C |
| JPT100 | -220 to + 630 | JIS C1604:1989 | 0.01 °C |
| Ni100 | - 60 to + 250 | DIN43760:1987 | 0.01 °C |
| Ni120 | -50 to + 170 | DIN43760:1987 | 0.01 °C |
| Pt100 | -200 to + 850 | IEC 751 | 0.01 °C |
| Pt100A | -200 to + 600 | Eurotherm Recorders SA | 0.09 °C |
| Pt1000 | -200 to + 850 | IEC 751 | 0.01 °C |

Table 4 RTD types, ranges and accuracies

DIMENSIONS

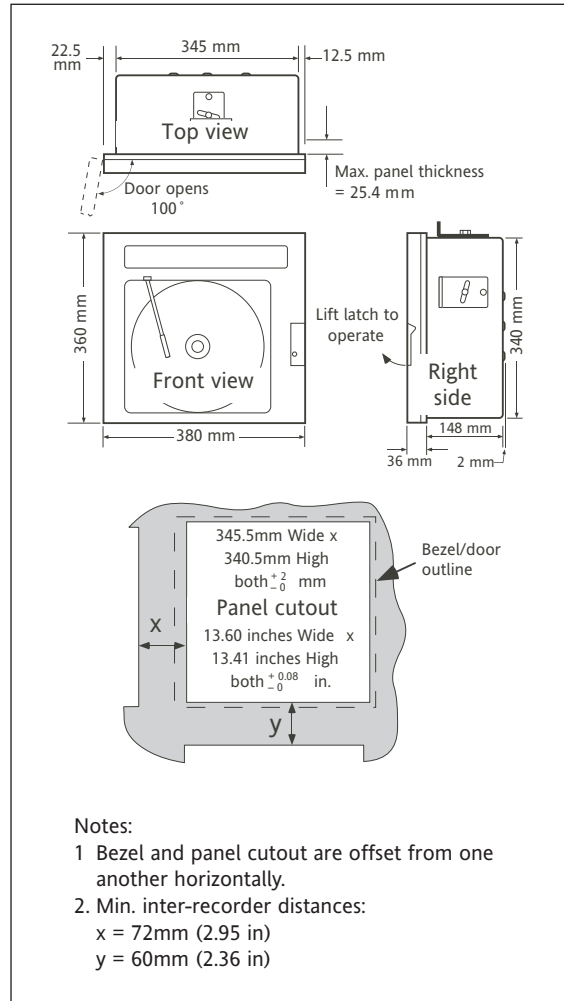

† All isolation figures are: DC to 65Hz; BS EN61010 Installation category II; pollution degree 2

ORDER CODE

| | | | | | | | | | | | | | | | | | | | | | | | | | | |
|-----|---|---|---|---|---|---|---|---|---|----|----|----|----|----|----|----|----|----|----|----|----|----|----|----|----|----|
| 394 | 1 | 2 | 3 | 4 | 5 | 6 | 7 | 8 | 9 | 10 | 11 | 12 | 13 | 14 | 15 | 16 | 17 | 18 | 19 | 20 | 21 | 22 | 23 | 24 | 25 | 26 |
| | | | | | | | | | X | | | | X | | | | | X | | | X | | X | | | X |

| | | | | | | | | | | | | | | | |
|----|----|----|----|----|----|----|----|----|----|----|----|----|----|----|----|
| 27 | 28 | 29 | 30 | 31 | 32 | 33 | 34 | 35 | 36 | 37 | 38 | 39 | 40 | 41 | 42 |
| X | 3 | X | X | X | X | | | 1 | X | | | X | X | | E |

1 No. of Channels

| | |
|---|------------|
| 1 | 1 Channel |
| 2 | 2 Channels |
| 3 | 3 Channels |
| 4 | 4 Channels |
| 6 | 6 Channels |

2 Operating Voltage

| | |
|---|-----------------------|
| 1 | 90-264V ac (50-60Hz) |
| 2 | 24-48V ac/dc 45-400Hz |

3 Input Channel 1 (note 1)

| | |
|---|-------------------------------|
| 0 | None (I/P card not fitted) |
| 1 | Universal V, mV, TC, RTD |
| 2 | 5V to 100V dc (inc 100:1 att) |
| 3 | 4 to 20mA (inc 250 ohm shunt) |

4 Input Channel 2 (note 1)

5 Input Channel 3 (note 1)

6 Input Channel 4 (note 1)

7 Input Channel 5 (note 1)

8 Input Channel 6 (note 1)

9 Fixed Digit

10 O/P Changeover Relays (note 2)

| | |
|---|------------------------|
| 0 | None |
| 2 | Two (one card) |
| 4 | Four (one card) |
| 6 | Six (one card) |
| 8 | Eight (two cards) |
| A | Ten (two cards) |
| B | Twelve (two cards) |
| C | Fourteen (three cards) |
| D | Sixteen (three cards) |
| E | Eighteen (three cards) |

11 Controller One (note 3)

| | |
|---|--------------------------|
| 0 | None |
| 1 | 2216 relay (R1/XX) |
| 2 | 2216 triac (T1/XX) |
| 3 | 2216 mA (D3/XX) |
| 4 | 2216 relay/relay (R1/R1) |
| 5 | 2216 relay/triac (R1/T1) |
| 6 | 2216 triac/triac (T1/R1) |
| 7 | 2216 triac/triac (T1/T1) |
| 8 | 2216 mA/relay (D3/R1) |
| 9 | 2216 mA/triac (D3/T1) |

12 Controller Two (note 3)

14 Case Style

| | |
|---|------------------------------------|
| 0 | IP54 Panel mounting |
| 1 | IP54 Pipe mounting |
| 2 | IP65 Panel mounting |
| 3 | IP65 Pipe mounting |
| 4 | IP65 Panel mount + stainless steel |
| 5 | IP65 Pipe mount + stainless steel |

15 Door Lock

| | |
|---|-----------|
| 0 | None |
| 1 | Door lock |

16 Transducer Pwr Supply

| | |
|---|----------------------------|
| 0 | None |
| 1 | 3 channels, 120V ac supply |
| 2 | 3 channels, 240V ac supply |
| 6 | 6 channels, 120V ac supply |
| 7 | 6 channels, 240V ac supply |

17 Totalisers, Timers & Counters (note 4)

| | |
|---|-----------------------------------|
| 0 | None |
| 2 | Two totalisers |
| 4 | Four totalisers |
| 6 | Six totalisers |
| C | Six timers & six counters |
| T | Six totalisers, timers & counters |

19 Customer Curve

| | |
|---|----------------|
| 0 | None |
| 1 | 32 point pairs |

20 Derived (Maths) Channels

| | |
|---|----------------------------|
| 0 | Maths pack not fitted |
| 1 | Basic maths pack fitted |
| 2 | Advanced maths pack fitted |
| 3 | Adv maths pack & exp disp |

21 Analogue Retransmission (note 2)

| | |
|---|------------------------|
| 0 | None |
| 2 | 2 channel O/P (1 card) |
| 4 | 4 channel O/P (1 card) |

23 Digital Communications (note 2)

| | |
|---|------------|
| 0 | None |
| 1 | Modbus RTU |

25 Window Material

| | |
|---|---------|
| 0 | Glass |
| 1 | Acrylic |

26 Fixed Digit

27 Fixed Digit

28 Certifications

| | |
|---|-----------------------|
| 3 | CE-European standards |
|---|-----------------------|

29 Fixed Digit

30 Fixed Digit

31 Fixed Digit

32 Fixed Digit

33 PC Card Driver

| | |
|---|-----------------------|
| 0 | None |
| A | ASCII logging |
| C | Config save & restore |
| P | Packed data logging |

34 Memory Card

| | |
|---|--------------|
| 0 | None |
| 3 | 2 Mb PC card |
| 5 | 6 Mb PC card |

35 Custom Message

| | |
|---|----------------------------|
| 1 | 20 messages (20 Character) |
|---|----------------------------|

36 Fixed Digit

37 Customer Logo (Door Label)

| | |
|----|-------------------|
| 01 | Eurotherm English |
|----|-------------------|

38 Additional Information

| | |
|---|----------------------------|
| 0 | None |
| 3 | Customer inspection |
| 4 | Calibration Cert 1 Channel |
| 5 | Calibration Cert 2 Channel |
| 6 | Calibration Cert 3 Channel |
| 7 | Calibration Cert 4 Channel |
| 8 | Calibration Cert 6 Channel |

40 Fixed Digit

41 Chart Supplied with Instrument

(note 5)

| | |
|------------|------------------|
| SV0394U050 | 7 Day, 50 Div |
| SV0394U060 | 7 Day, 60 Div |
| SV0394U070 | 7 Day, 70 Div |
| SV0394U080 | 7 Day, 80 Div |
| SV0394U090 | 7 Day, 90 Div |
| SV0394U100 | 7 Day, 100 Div |
| TW0394U050 | 24 Hour, 50 Div |
| TW0394U060 | 24 Hour, 60 Div |
| TW0394U070 | 24 Hour, 70 Div |
| TW0394U080 | 24 Hour, 80 Div |
| TW0394U090 | 24 Hour, 90 Div |
| TW0394U100 | 24 Hour, 100 Div |

42 Installation Operation Manual

| | |
|---|---------|
| E | English |
|---|---------|

- NOTES:**
- Inputs *MUST* be selected in order (e.g. you cannot specify inputs 1 and 3 and enter '0' for input 2). Any universal input can be configured for TC, RTD, mV dc and V dc directly. Inputs are specified as 4-20mA are universal inputs with a 250ohm shunt resistor provided. Inputs specified as 5V to 100 V dc are universal inputs fitted with a 1M ohm voltage divider. Channel 1 cannot be configured to respond to a contact closure.
 - There are THREE option card positions. A relay card takes one position, communications card takes one position, controllers use one position.
 - PID control with 85-264V ac power supply and 1 or 2 outputs as selected requires 1 option slot.
 - Totalisers (integrators) are user assignable to any input or derived (math) channel.
 - One pack of 100 charts is included as standard. Other charts WITH AND WITHOUT RANGE PRINTING are available, consult the factory for further information.

INPUT BOARD SIGNAL WIRING

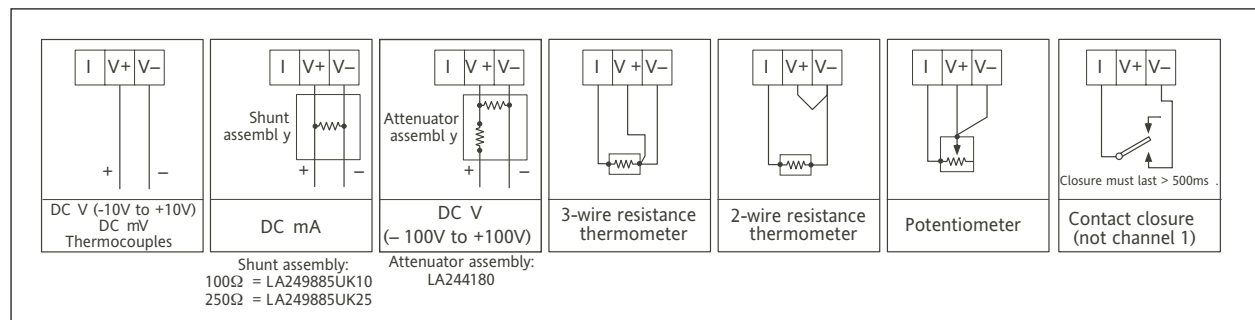

ELECTRICAL INSTALLATION

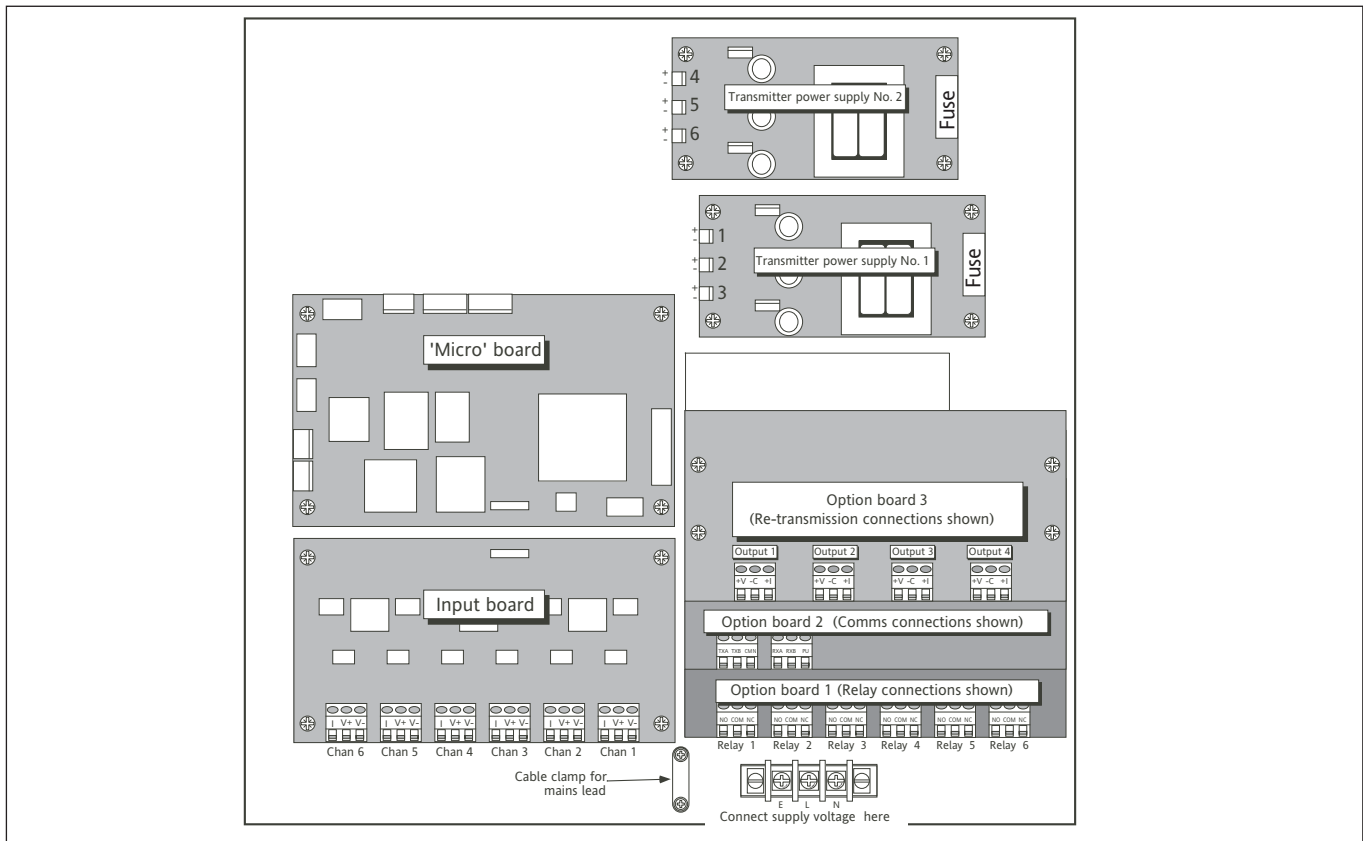

Eurotherm: International sales and service

Understanding and providing local support is a key part of Eurotherm business. Complementing worldwide Eurotherm offices are a whole range of partners and a comprehensive technical support team, to ensure you get a service you will want to go back to.

AUSTRALIA Sydney
Eurotherm Pty. Ltd.
T (+61 2) 9838 0099
F (+61 2) 9838 9288
E info.au@eurotherm.com

AUSTRIA Vienna
Eurotherm GmbH
T (+43 1) 7987601
F (+43 1) 7987605
E info.at@eurotherm.com

BELGIUM & LUXEMBOURG Moha
Eurotherm S.A./N.V.
T (+32) 85 274080
F (+32) 85 274081
E info.be@eurotherm.com

BRAZIL Campinas-SP
Eurotherm Ltda.
T (+5519) 3707 5333
F (+5519) 3707 5345
E info.br@eurotherm.com

DENMARK Copenhagen
Eurotherm Danmark AS
T (+45 70) 234670
F (+45 70) 234660
E info.dk@eurotherm.com

FINLAND Abo
Eurotherm Finland
T (+358) 22506030
F (+358) 22503201
E info.fi@eurotherm.com

FRANCE Lyon
Eurotherm Automation SA
T (+33 478) 664500
F (+33 478) 352490
E info.fr@eurotherm.com

GERMANY Limburg
Eurotherm Deutschland GmbH
T (+49 6431) 2980
F (+49 6431) 298119
E info.de@eurotherm.com

HONG KONG & CHINA
Eurotherm Limited North Point
T (+85 2) 28733826
F (+85 2) 28700148
E info.hk@eurotherm.com

Guangzhou Office
T (+86 20) 8755 5099
F (+86 20) 8755 5831
E info.cn@eurotherm.com

Beijing Office
T (+86 10) 6567 8506
F (+86 10) 6567 8509
E info.cn@eurotherm.com

Shanghai Office
T (+86 21) 6145 1188
F (+86 21) 6145 1187
E info.cn@eurotherm.com

INDIA Chennai
Eurotherm India Limited
T (+91 44) 24961129
F (+91 44) 24961831
E info.in@eurotherm.com

IRELAND Dublin
Eurotherm Ireland Limited
T (+353 1) 4691800
F (+353 1) 4691300
E info.ie@eurotherm.com

ITALY Como
Eurotherm S.r.l.
T (+39 031) 975111
F (+39 031) 977512
E info.it@eurotherm.com

KOREA Seoul
Eurotherm Korea Limited
T (+82 31) 2738507
F (+82 31) 2738508
E info.kr@eurotherm.com

NETHERLANDS Alphen a/d Rijn
Eurotherm B.V.
T (+31 172) 411752
F (+31 172) 417260
E info.nl@eurotherm.com

NORWAY Oslo
Eurotherm A/S
T (+47 67) 592170
F (+47 67) 118301
E info.no@eurotherm.com

POLAND Katowice
Invensys Eurotherm Sp z o.o.
T (+48 32) 2185100
F (+48 32) 2177171
E info.pl@eurotherm.com

SPAIN Madrid
Eurotherm España SA
T (+34 91) 6616001
F (+34 91) 6619093
E info.es@eurotherm.com

SWEDEN Malmo
Eurotherm AB
T (+46 40) 384500
F (+46 40) 384545
E info.se@eurotherm.com

SWITZERLAND Wollerau
Eurotherm Produkte (Schweiz) AG
T (+41 44) 7871040
F (+41 44) 7871044
E info.ch@eurotherm.com

UNITED KINGDOM Worthing
Eurotherm Limited
T (+44 1903) 268500
F (+44 1903) 265982
E info.uk@eurotherm.com
www.eurotherm.co.uk

U.S.A. Leesburg VA
Eurotherm Inc.
T (+1 703) 443 0000
F (+1 703) 669 1300
E info.us@eurotherm.com
www.eurotherm.com

ED55

© Copyright Eurotherm Limited 2007

Invensys, Eurotherm, the Eurotherm logo, Chessell, EurothermSuite, Mini8, Eycon, Eyriss, EPower and Wonderware are trademarks of Invensys plc, its subsidiaries and affiliates. All other brands may be trademarks of their respective owners.

All rights are strictly reserved. No part of this document may be reproduced, modified, or transmitted in any form by any means, nor may it be stored in a retrieval system other than for the purpose to act as an aid in operating the equipment to which the document relates, without the prior written permission of Eurotherm limited.

Eurotherm Limited pursues a policy of continuous development and product improvement. The specifications in this document may therefore be changed without notice. The information in this document is given in good faith, but is intended for guidance only.

Eurotherm Limited will accept no responsibility for any losses arising from errors in this document.