

# Model 392

Continuous-trace circular-chart recorder

Installation and  
Operation Manual



Invensys

EUROTHERM

### Consumables part numbers

| Pens (Pack of two) |          |
|--------------------|----------|
| Channel 1 (blue)   | LA203211 |
| Channel 2 (red)    | LA203212 |
| Channel 3 (green)  | LA203213 |
| Channel 4 (black)  | LA203214 |

| Standard charts |              |
|-----------------|--------------|
| 12 hour         | GD239347Uxxx |
| 24 hour         | GD239347Uxxx |
| 7 day           | GD239347Uxxx |

(xxx = number of chart divisions  
= 050, 060, 070, 080, 100, 150.)  
Example: GD239347U100  
is a 24 hour chart, marked 0 to 100.

### Associated Manuals

|          |  |
|----------|--|
| HA204393 | Controller and Setpoint Generator manual |
| HA204394 | Serial communications manual             |



## Declaration of Conformity

|                                     |  |
|-------------------------------------|--|
| <b>Manufacturer's name:</b>         | <b>Eurotherm Recorders Limited</b>   |
| <b>Manufacturer's address</b>       | <b>Dominion Way, Worthing, West Sussex,<br/>BN14 8QL, United Kingdom.</b>  |
| <b>Product type:</b>                | <b>Industrial Chart Recorder</b>   |
| <b>Models:</b>                      | <b>392 (Status level C05 or higher)<br/>(Basic instrument; also basic instrument plus<br/>Transmitter Power Supply option)</b> |
| <b>Safety specification:</b>        | <b>IEC348:1978</b>   |
| <b>EMC emissions specification:</b> | <b>EN50081-2 (Group1; Class A)</b>   |
| <b>EMC immunity specification:</b>  | <b>EN50082-2</b>   |

Eurotherm Recorders Limited hereby declares that the above products conform to the safety and EMC specifications listed. Eurotherm Recorders Limited further declares that the above products comply with the EMC Directive 89 / 336 / EEC amended by 93 / 68 / EEC, and also with the Low Voltage Directive 73 / 23 / EEC

Signed:

*P. De La Nougerède*

Dated:

*18-12-96*

Signed for and on behalf of Eurotherm Recorders Limited  
Peter De La Nougerède  
(Technical Director)



All rights are strictly reserved. No part of this document may be reproduced, modified, or transmitted in any form by any means, nor may it be stored in a retrieval system other than for the purpose to act as an aid in operating the equipment to which the document relates, without the prior written permission of Eurotherm limited.

Eurotherm Limited pursues a policy of continuous development and product improvement. The specifications in this document may therefore be changed without notice. The information in this document is given in good faith, but is intended for guidance only. Eurotherm Limited will accept no responsibility for any losses arising from errors in this document.



**100 mm CIRCULAR-CHART RECORDER****INSTALLATION AND OPERATION MANUAL****LIST OF CONTENTS**

| <b>Section</b>   | <b>Page</b> |
|--|-------------|
| SAFETY NOTES .....                                       | 5           |
| SYMBOLS USED ON THE RECORDER LABELLING .....             | 6           |
| WARRANTY STATEMENT .....                                 | 6           |
| <b>1 INTRODUCTION .....</b>                              | <b>7</b>    |
| 1.1 MANUAL LAYOUT .....                                  | 7           |
| 1.2 RECORDER DESCRIPTION .....                           | 7           |
| 1.3 UNPACKING AND INSPECTION .....                       | 7           |
| <b>2 INSTALLATION .....</b>                              | <b>8</b>    |
| 2.1 MECHANICAL INSTALLATION .....                        | 8           |
| 2.1.1 Panel mounting .....                               | 8           |
| 2.1.2 Wall mounting .....                                | 8           |
| 2.1.3 Pipe mounting .....                                | 8           |
| 2.2 ELECTRICAL INSTALLATION .....                        | 9           |
| 2.2.1 Supply voltage and case heater option wiring ..... | 9           |
| 2.2.2 Supply Voltage selection .....                     | 10          |
| 2.2.3 Signal wiring .....                                | 10          |
| ATTENUATOR EXAMPLE .....                                 | 10          |
| PINOUTS .....  | 10          |
| TRANSMITTER POWER SUPPLY WIRING .....                    | 11          |
| 2.2.4 Wiring installation .....                          | 12          |
| 2.3 CIRCUIT BOARD LOCATION .....                         | 12          |
| 2.4 INPUT BOARD HARDWARE CONFIGURATION .....             | 13          |
| 2.4.1 Board number .....                                 | 13          |
| 2.4.2 CJC/RTD .....                                      | 13          |
| 2.4.3 TC/RTD .....                                       | 13          |
| 2.4.4 Upscale/Downscale drive .....                      | 13          |
| 2.5 CHART FITTING .....                                  | 14          |
| 2.6 PEN FITTING .....                                    | 15          |
| <b>3 OPERATION .....</b>                                 | <b>16</b>   |
| 3.1 OPERATING DISPLAYS .....                             | 16          |
| 3.1.1 Input/maths channel values .....                   | 16          |
| 3.1.2 Totaliser displays .....                           | 16          |
| 3.1.3 Alarm information .....                            | 17          |
| INDIVIDUAL CHANNEL ALARMS .....                          | 17          |
| GLOBAL ALARM SYMBOL .....                                | 17          |
| INSTRUMENT ALARM .....                                   | 17          |
| 3.2 OPERATOR MENUS .....                                 | 18          |
| 3.2.1 Operator menu items .....                          | 18          |



## List of Contents (Cont.)

| Section   | Page      |
|---|-----------|
| 4.11 RETRANSMISSION OPTION .....                      | 45        |
| 4.11.1 Hardware configuration .....                   | 45        |
| 4.11.2 Software configuration .....                   | 46        |
| CONFIGURABLE ITEMS .....                              | 46        |
| 4.12 CONTACT (EVENT) INPUTS .....                     | 47        |
| 4.13 EVENT PEN .....                                  | 47        |
| <b>5 CALIBRATION .....</b>                            | <b>48</b> |
| 5.1 INPUT CHANNEL CALIBRATION .....                   | 49        |
| 5.1.1 Input channel calibration procedure .....       | 49        |
| 5.2 CJC SENSOR CALIBRATION .....                      | 50        |
| 5.2.1 CJC sensor calibration procedure .....          | 50        |
| 5.3 RESTORE FACTORY CALIBRATION .....                 | 50        |
| 5.3.1 Restore factory calibration procedure .....     | 50        |
| 5.4 PEN CALIBRATION .....                             | 51        |
| 5.4.1 Pen calibration procedure .....                 | 51        |
| 5.5 VIEW OPTIONS .....                                | 51        |
| 5.6 RETRANSMISSION OUTPUT CALIBRATION .....           | 52        |
| 5.6.1 Retransmission calibration procedure .....      | 52        |
| 5.7 RETURN RETRANSMISSION OUTPUT TO FACTORY CAL ..... | 52        |
| 5.7.1 Restore factory calibration procedure .....     | 52        |
| <b>6 UPGRADE AND FAULT LOCATION .....</b>             | <b>53</b> |
| 6.1 PROMS AND RAM .....                               | 53        |
| 6.2 RECORDER UPGRADE .....                            | 53        |
| 6.3 FAULT LOCATION .....                              | 54        |
| <b>ANNEX A SPECIFICATION .....</b>                    | <b>56</b> |
| <b>INDEX .....</b>                                    | <b>58</b> |

This page is deliberately left blank

---

**SAFETY NOTES**

---

**WARNING**

Any interruption of the protective conductor inside or outside the apparatus, or disconnection of the protective earth terminal is likely to make the apparatus dangerous under some fault conditions. Intentional interruption is prohibited.

---

Note: in order to comply with the requirements of safety standard BS EN61010, the recorder shall have one of the following as a disconnecting device, fitted within easy reach of the operator, and labelled as the disconnecting device.

- a. A switch or circuit breaker which complies with the requirements of IEC947-1 and IEC947-3
  - b. A separable coupler which can be disconnected without the use of a tool
  - c. A separable plug, without a locking device, to mate with a socket outlet in the building.
- 

1. Before any other connection is made, the protective earth terminal shall be connected to a protective conductor. The mains (supply voltage) wiring must be terminated within the connector in such a way that, should it slip in the cable clamp, the Earth wire would be the last wire to become disconnected.
2. Before switching on the apparatus, ensure that the connected supply voltage is compatible with the apparatus. Ensure that only fuses with the required rated current and of the specified type are used for replacement. The use of makeshift fuses and the short-circuiting of fuse holders is prohibited.
3. Any adjustment, maintenance and repair of the opened apparatus under voltage, should be avoided as far as possible and, if inevitable, shall be carried out only by a skilled person who is aware of the hazard involved. When the apparatus is connected to its supply, terminals may be live, and the opening of covers or internal assemblies (except for those designed for access to be gained by hand) is likely to expose live parts.





Two large capacitors between the power transformer and the line voltage select switch on the main circuit board may temporarily retain a hazardous charge after the supply voltage has been disconnected. These capacitors must not be touched for at least 10 seconds after supply voltage disconnection.

4. Where conductive pollution (e.g. condensation, carbon dust) is likely, adequate air conditioning/filtering/sealing etc. must be installed in the recorder enclosure.
5. Signal and supply voltage wiring should be kept separate from one another. Where this is impractical, shielded cables should be used for the signal wiring.
6. This apparatus has been designed and tested in accordance with applicable safety standards, and is supplied in a safe condition. This instruction manual (as supplemented by any associated auxiliary manuals) contains some information and warnings which have to be followed by the user to ensure safe operation and to retain the apparatus in safe condition. If the equipment is used in a manner not specified by the manufacturer, the protection provided by the equipment might be impaired. Whenever it is likely that protection has been impaired, the unit shall be made inoperative, and secured against accidental operation. The manufacturer's nearest service centre should be contacted for advice.

\* A full definition of 'Hazardous' voltages appears under 'Hazardous live' in BS EN61010. Briefly, under normal operating conditions, hazardous voltages are defined as being > 30V RMS (42.2V peak) or > 60V dc.

## SYMBOLS USED ON THE RECORDER LABELLING

One or more of the symbols below may appear as a part of the recorder labelling.

|   |                                      |
|---|--------------------------------------|
|  | Refer to the Manual for instructions |
|  | Protective Earth                     |
|  | This recorder for ac supply only     |
|  | This recorder for dc supply only.    |
|  | Risk of electric shock               |

## WARRANTY STATEMENT

This product is warranted against defects in materials and workmanship for the specified period from the date of shipment. During the warranty period the manufacturer will, at its option, either repair or replace products which prove to be defective.

Warranty service at the buyer's facility can be provided only under prior agreement by the manufacturer or its representative, and the buyer may be required to pay round-trip travel expenses.

In all cases, the buyer has the option of returning the product for Warranty service to a facility designated by the manufacturer or its representatives. The buyer shall prepay shipping charges for products returned to a service facility, and the manufacturer or its representative shall pay for the return of the product to the buyer.

## LIMITATION OF WARRANTY

The foregoing warranty shall not apply to defects arising from:

Improper or inadequate maintenance by the user.

Improper or inadequate site preparation

Unauthorized modification or misuse

Operation of the product in unfavourable environments, especially, high temperature, high humidity, corrosive or other damaging atmospheres.

## DISCLAIMER

No other warranty is expressed or implied. The manufacturer specifically disclaims the implied warranties of merchantability and fitness for a particular purpose.

## EXCLUSIVE REMEDIES

The remedies provided are the buyer's sole and exclusive remedies. The manufacturer shall not be liable for any direct, indirect, special incidental or consequential damages.

## CALIBRATION ACCURACY

This product was thoroughly tested to ensure compliance with the published specifications. All instruments used in production and final test are regularly inspected to maintain accuracy of calibration traceable to the National Bureau of Standards. The user should be satisfied that the performance of the product as received meets expectations and, as part of a programme of planned maintenance, should periodically check calibration accuracy against reliable standards,

## 1 INTRODUCTION

This manual is intended to familiarise the user with the basic installation, operations and routine maintenance of a 100 mm continuous-trace circular-chart recorder. For details of other manuals associated with this recorder, please refer to the list of associated manuals on the inside front cover.

### 1.1 MANUAL LAYOUT

This manual is divided into a number of sections as follows:

- Section 1 This describes the manual and its organisation and gives a brief description of the recorder
- Section 2 Installation. Gives mechanical and electrical installation details.
- Section 3 Operation. Gives details of the operating displays of the recorder.
- Section 4 Configuration. Gives details of how to set the recorder up to measure and record the required inputs.
- Section 5 Calibration. Gives details of how to calibrate input and output channels and how to align the pens with the chart.
- Section 6 Diagnostics. This section gives diagnostic and fault-finding details.
- Annex A The technical specification for the recorder.

### 1.2 RECORDER DESCRIPTION

The recorder is a user-configurable 1, 2, 3 or 4-pen instrument producing traces on a circular chart of 100 mm calibrated width. The operator interface is an integral membrane keyboard and associated vacuum fluorescent display (two lines, each of twenty characters).

Configuration is divided into a number of sections, with logical menu-driven steps displayed in plain English. The sectional nature of the menu structure allows the user to select only those items required for a particular application.

Modular construction and the use of surface-mount technology produce a compact design which is easy to maintain and to upgrade.

### 1.3 UNPACKING AND INSPECTION

The recorder is despatched in a special pack designed to give adequate protection during transit. Should the outer box show signs of damage, it should be opened immediately and the recorder examined. If there is evidence of damage, the instrument should not be operated and the local representative contacted for instructions. After the recorder has been removed from its packing, the packing should be examined to ensure that all accessories and documentation have been removed.

Open the door of the recorder by lifting up the bottom of the catch and pulling it outwards and upwards (figure 1.3a). Open the door and loosen the captive Platen locking screw (figure 1.3b) to release the chart platen. Open the platen, and inspect the recorder for mechanical integrity. Re-secure the platen and latch the door shut. If the recorder is to be stored before use, return it to the packing in which it was received. If not, the recorder may now be mounted as described below.

Once the recorder has been installed, any internal packing should be removed, and stored with the external packing against future transport requirements.

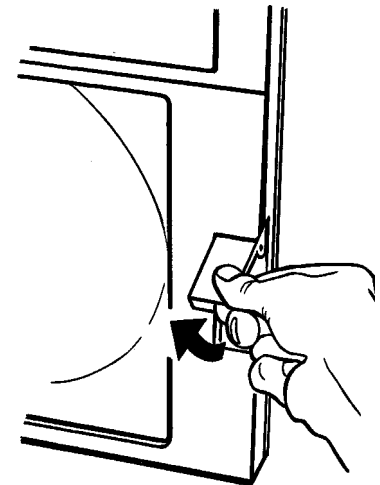

Figure 1.3a Door catch

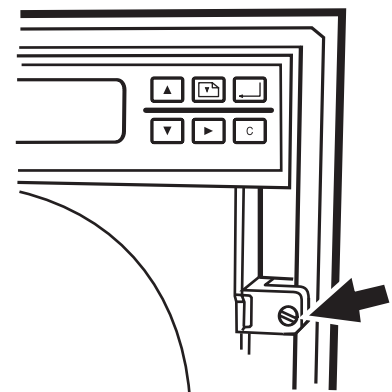

Figure 1.3b Platen securing screw

## 2 INSTALLATION

### 2.1 MECHANICAL INSTALLATION

Mechanical installation details are shown in figure 2.1

#### 2.1.1 Panel mounting

The recorder is inserted through the panel aperture from the front of the panel. With the weight of the recorder supported, the recorder is secured using the two clamp brackets supplied, either at the top and bottom or at the right and left sides of the recorder.

#### 2.1.2 Wall mounting

The clamp brackets are reversed for wall mounting.

#### 2.1.3 Pipe mounting

Mounting brackets to suit a 50 mm (2 inch) pipe are also available.

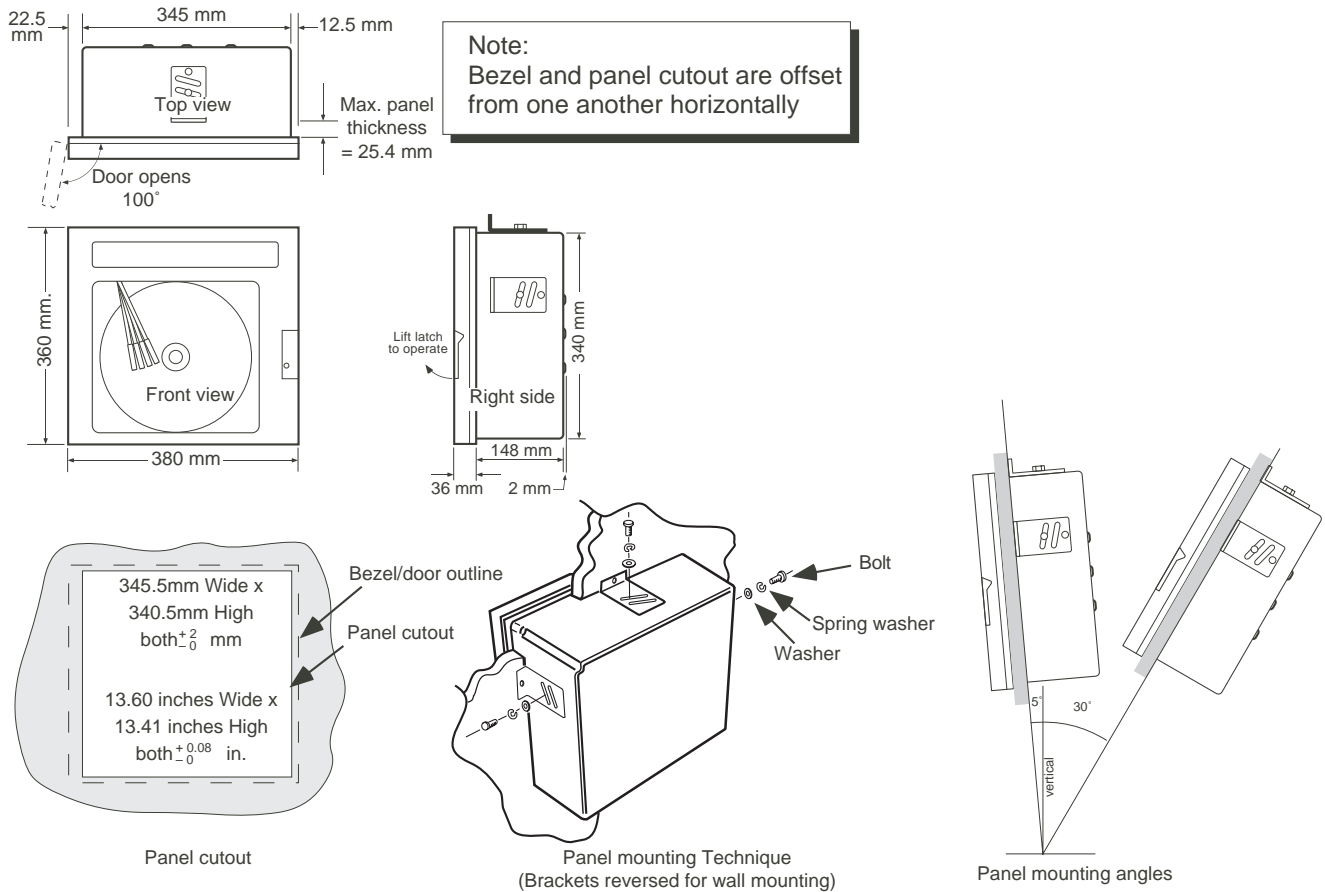

Figure 2.1 Mechanical installation

## 2.2 ELECTRICAL INSTALLATION

Details for connecting the line supply and for signal wiring are shown in figure 2.2.1

### 2.2.1 Supply voltage and case heater option wiring

There are two mains connectors on the board wired in parallel. One is intended for supply voltage connection - the other is for the case heater option. Either connector can be used for either function. The connector for supply voltage connection is in two parts; one part mounted on the main circuit board, the other (mating) part is supplied in the recorder accessory pack. The wiring details for this connector are shown in figure 2.2.1. It must be ensured that the bared ends of the wires are fully inserted before the clamping screws are tightened. The safety earth connection is to be made to the earthing point located in the bottom right hand corner of the case. The safety earth conductor must be of such a length that it would be the last conductor to become disconnected should the mains (line) cord be pulled out of the connector.

The earth connector pin on the main board connector is the same length as the Line and Neutral pins - local codes of practise should be consulted before making an earth connection to this point.

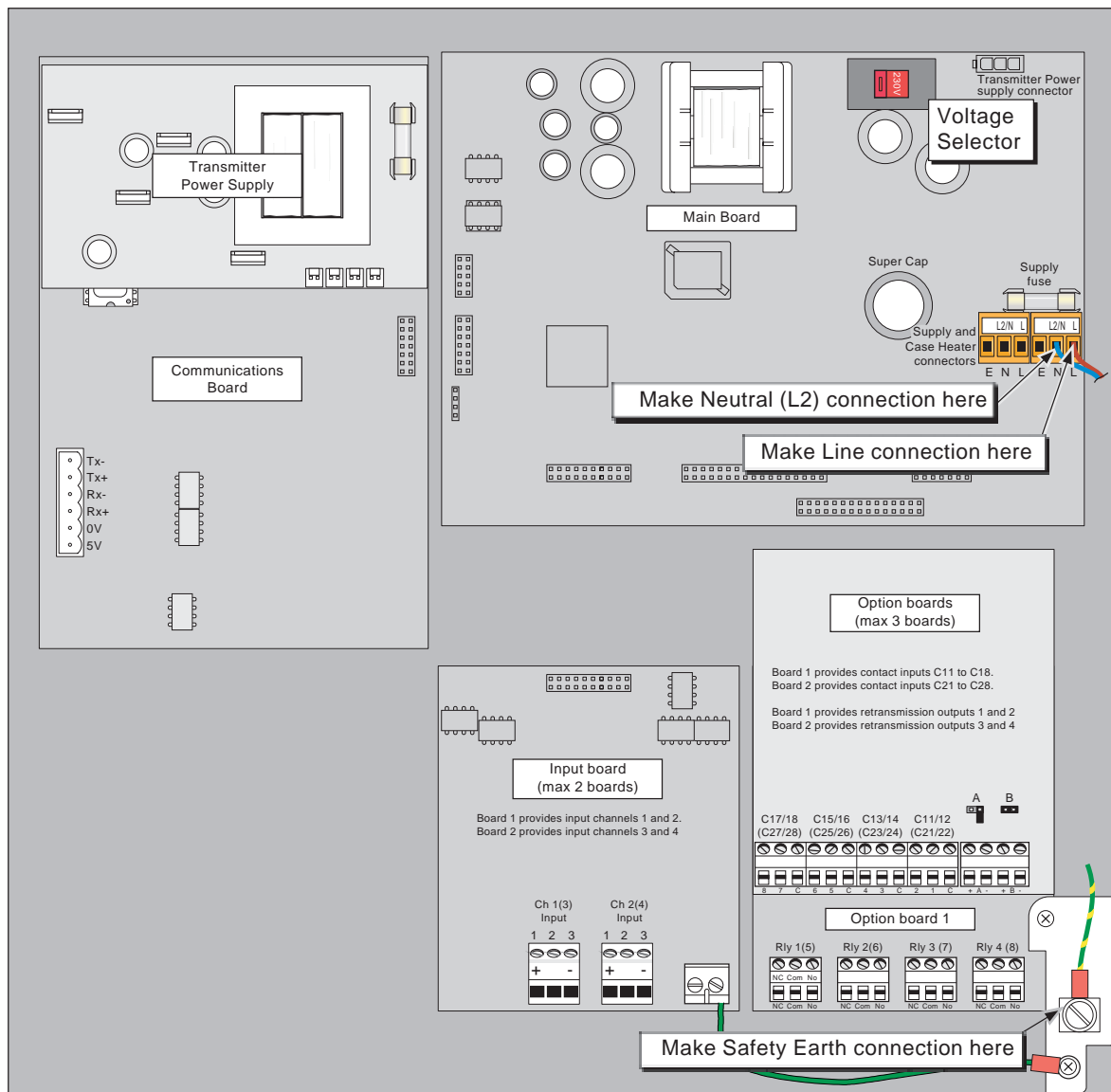

Figure 2.2.1 Circuit board location, and Supply Voltage connection

### 2.2.2 Supply Voltage selection

The supply voltage selector is located on the main circuit board, near the top wall of the case, as shown in figure 2.2.1, above. Ensure that the slider is in such a position that the number displayed (115 or 230) matches the supply voltage that is to be connected. The supply frequency range for both voltage settings is 45 to 65 Hz.

The '115' position is suitable for supply voltages of between 90 and 132 V ac and must be fused with a slow blow, 1 Amp, 20 mm fuse link.

The '230' position is suitable for supply voltages of between 180 and 264 V ac and must be fused with a slow blow, 1/2 Amp (500 mA), 20 mm fuse link.

### 2.2.3 Signal wiring

The recorder can be connected and configured to operate with a variety of signal sources such as thermocouples, resistance thermometers (RTDs), dc current, dc voltage etc.

The configuration of the recorder may require the moving of one or more 'jumpers' on the input amplifier board, and / or the use of input conditioning boards to provide shunts or attenuators.

#### ATTENUATOR EXAMPLE

A voltage of 2 to 10 V dc is to be applied across a channel input. As the maximum input voltage is 5 Volts the 100:1 attenuator must be used, resulting in a recorder input range of 20 mV (2V/100) to 100 mV (10V/100).

#### PINOUTS

The locations of the input and option boards are shown in figure 2.2.1

Signal wiring termination for the input board is shown in figure 2.2.3a. Signal wiring termination for retransmission outputs, relay outputs and event inputs is shown in figure 2.2.3b.

#### Notes

1. When wiring RTDs, lead length and diameter must be chosen such that lead lengths are equal and that each lead exhibits no more than 10 ohms resistance between the recorder and the RTD.
2. For event input closures, high quality, low resistance contacts must be used which are suitable for dry (i.e. non-powered) operation.

#### Caution

The input circuitry is protected against over-voltage up to 24 V dc. Voltages above this can cause damage to the input board.

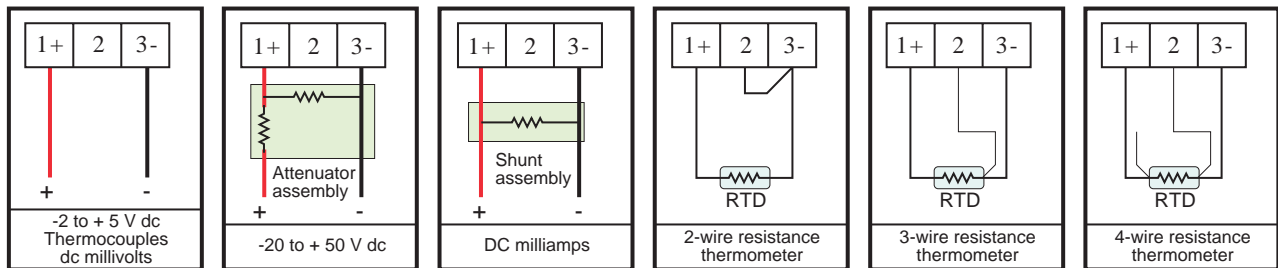

Figure 2.2.3a Input board wiring

2.2.3 SIGNAL WIRING (Cont.)

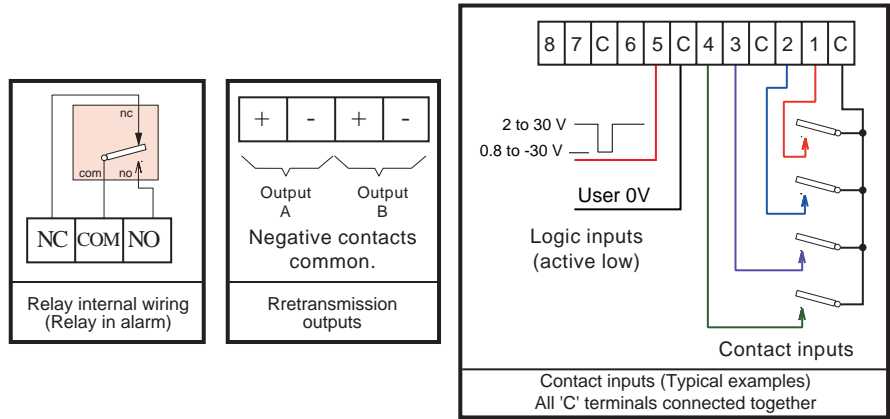

Figure 2.2.3b Option wiring

TRANSMITTER POWER SUPPLY WIRING

Transmitters can be powered by an internal 24V nom. power supply, or by an external supply. Typical wiring for a single channel is given in figure 2.2.3c.

**Caution**

A transmitter in a current loop must not be shorted. If it is, the transmitter power supply is essentially connected directly across the input shunt. In such a case the shunt will almost certainly suffer damage.

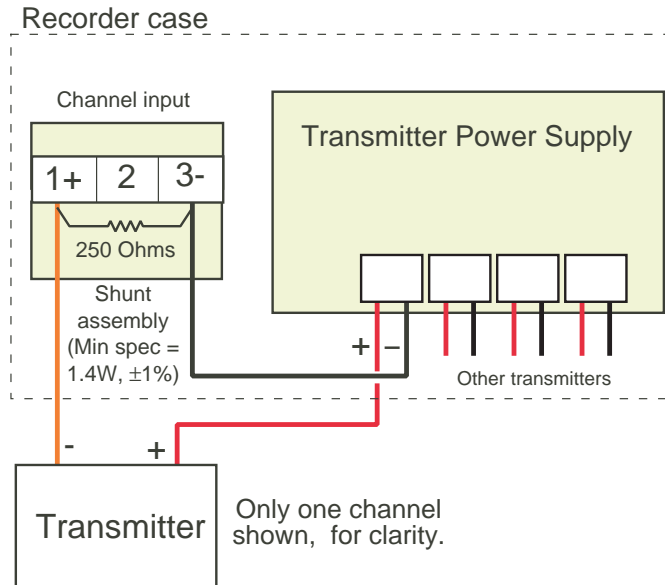

Figure 2.2.3c Typical transmitter power supply wiring

## 2.2.4 Wiring installation

In order to ensure maximum recorder performance, proper wiring installation practises must be followed. Failure to do so can result in a range of problems, from loss of configuration to component failure, caused by transmitted or radiated electrical noise. Proper consideration must be given to local noise sources and appropriate suppression steps taken to minimise any potential problems. Among the most common sources of noise are: Relays, SCRs, valve solenoids, electric motors, power line disturbance, wire-to-wire coupling, electrostatic discharge (ESD) and radio-frequency interference (RFI).

To achieve the best results, the following notes should be considered:

1. Low level signal wiring such as that associated with thermocouples, RTDs and current loops should always be kept separate from power and control output wiring.
2. Signal input wiring should be twisted pairs/triplets etc. and the conductors should be stranded rather than solid in construction. All signal wiring should use ground-shielded wires, or be routed through grounded conduit. This minimises the effects of RFI and ESD.
3. Special care should be taken when wiring to relay or solenoid coils, as large transients are produced when coils (or any other inductive devices) are switched. This problem can be eliminated by the use of suitable suppression devices across the coil. Coil transients can also be transmitted through the air, so the recorder itself should be mounted as far as possible from power control devices and/or wiring.
4. When line power is poorly regulated and / or subject to voltage surges or transients, consideration should be given to the use of a line conditioning/transient suppressing line power regulator. Process control motors, valves, relays and heaters should not be connected to the same power lines that are used for instrumentation.
5. The connection of the recorder to a proper safety earth ground is essential. Such a connection not only reduces the possibility of electric shock, but also provides the required return for the recorder line power filters,
6. All local electrical codes of practise must be followed when installing any instrumentation.

## 2.3 CIRCUIT BOARD LOCATION

The input boards and option boards are located as shown in figure 2.3. There are a number of different types of option board, as listed below, any three of which may be used in any of the three available positions. The card types are as follows:

Two relay board containing either relays 1 and 2 or relays 5 and 6.

Four relay board containing either relays 1 to 4 or relays 5 to 8

Combined board - 8 Event inputs and 1 retransmission channel

Combined board - 8 Event inputs and 2 retransmission channels

The serial communications and transmitter power supply option boards are mounted separately, as shown.

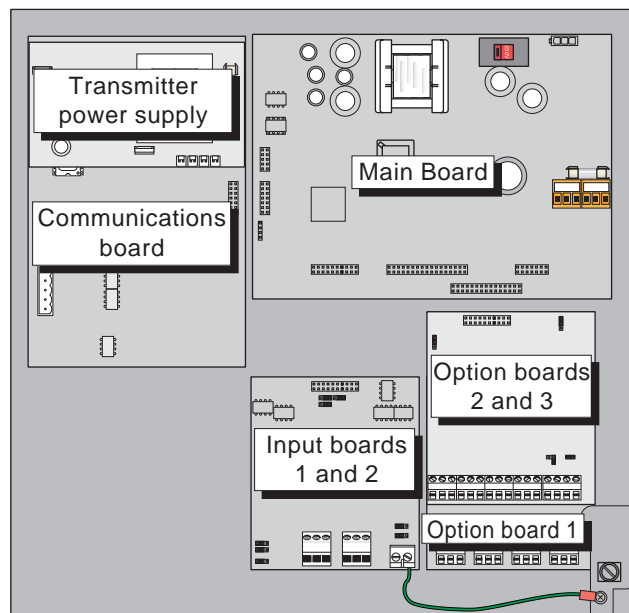

Figure 2.3 Circuit board locations

## 2.4 INPUT BOARD HARDWARE CONFIGURATION

On each input board, there are eight links to be checked or set. The screen printing on the board surface identifies the link positions.

### 2.4.1 Board number

This is set by three links (JP2, JP3, JP4) near the top end of the circuit board, Board 1 (channels 1 and 2) is the lower of the two cards with Board 2 (channels 3 and 4) (If fitted) set above Board 1 on standoffs.

Each of the three links must be fitted across the centre and right-hand pin to define this as board 1.

Each of the three links must be fitted across the centre and left-hand pin to define this as board 2.

### 2.4.2 CJC/RTD

This link (JP1) must be set to RTD if channel 1 (3) is to be used for RTD input, or to CJC for any other input type. This link must be used in a way appropriate to the TC/RTD links described below.

**Notes:**

- 1 If the link is set to RTD neither channel can be used for anything other than RTD inputs.
- 2 If the link is set to CJC, channel 2 (4) may be used for RTD or T/C etc. inputs, but channel 1 (3) cannot be used for RTD measurements.

### 2.4.3 TC/RTD

This link must be set for each channel. Channels with this link set to RTD can be used only for RTD inputs. Channels with this link set to TC, are suitable for all other input types. The setting of the CJC/RT (above) link must be appropriate to the setting of this TC/RTD link.

### 2.4.4 Upscale/Downscale drive

These links define the behaviour of the channel in the case of a broken thermocouple input circuit. Locating the link to 'Upscale' means that if the recorder detects an open circuit, the channel will drive to the full scale position and remain there until the problem is solved. Locating the link to 'Downscale' is similar, but the recorder drives the trace to chart zero instead of full scale.

**Note**

If the associated TC/RTD link is set to RTD, the link must be removed. It is recommended that, for safekeeping, the link be 'parked' sideways on the centre pin of the connector.

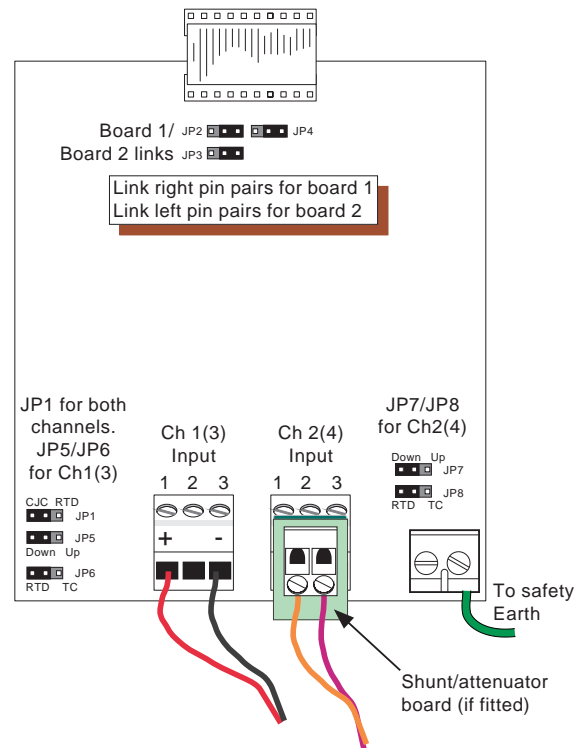

Figure 2.4 Input board link locations



---

## 2.6 PEN FITTING

---

### Caution

Pens may be changed only whilst parked, as described below. An attempt to change pens whilst 'live', will result in damage to the recorder.

---

Note: It is recommended that the operator wear plastic gloves whilst handling pens, in order to avoid ink contamination of the hands.

---

Note: Channel 1 (blue) is the bottom-most pen. Channel 2 (red) is next, followed by channel 3 (green) and channel 4 (top-most) is black.

---

1. Open the recorder door as described in [section 1.3](#).
2. Move the pen lift lever (figure 2.5, above, to the 'Lift' position. With recorder power on, and the recorder initialised, press the right arrow key. Press the Page key repeatedly until 'Pen Park' appears at the display. Use the up or down arrow to change 'Off' to 'On', then press the enter key. This causes recording to stop and the pens to fan for easy access.
3. Carefully, whilst supporting the pen arm, pull the exhausted pen off the relevant pen arm. Remove the replacement pen from its packaging. Remove the tip protector from the pen tip.
4. Carefully, whilst supporting the pen arm slide the new pen onto the pen arm, sliding the pen into the clip until it stops.
5. When all the pens have been replaced, use the up or down arrow key, followed by 'Enter' to set Pen Park to off. The pens swing over to the left edge of the chart.
6. Move the pen lift lever to the mid (Run Lifted) position, until the pens have moved to their tracing positions, then, move the pen lift lever to the lowest (Run) position to resume tracing.
7. Operate the 'C' key to return to the background display, then close and latch the door.

### 3 OPERATION

#### 3.1 OPERATING DISPLAYS

The operating display at the operator interface normally scrolls through all the active channels (where 'channels' includes input channels, totalisers and maths channels) at nine second intervals. To override this scrolling process, the up and/or down arrow keys can be used to step through the 'channels' manually. Operating the 'Enter' key stops the scrolling process, leaving the current 'channel' permanently displayed. Operation of the up or down arrow key restarts the scrolling process.

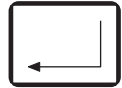

Enter key

**Note:** Refer to the Control Loop and Setpoint Generator manual for details of Control loop and Setpoint Generator displays.

##### 3.1.1 Input/maths channel values

Individual displays show the 16-character descriptor, channel number, value, units and alarm information as shown, for an input channel, in figure 3.1.1. Maths channels are similar, except that the channel number 'Ch1' is replaced by 'DVI' (DV = Derived Variable).

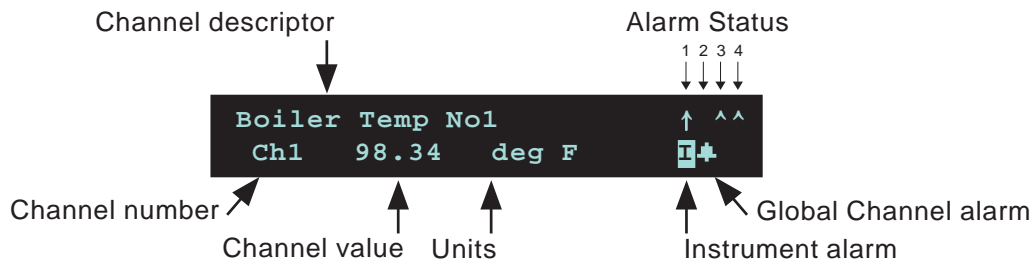

Figure 3.1.1 input channel display

##### 3.1.2 Totaliser displays

Totaliser displays (figure 3.1.2) are similar to other channel displays, but contains only the totaliser descriptor, its value, units and global/instrument alarm symbols.

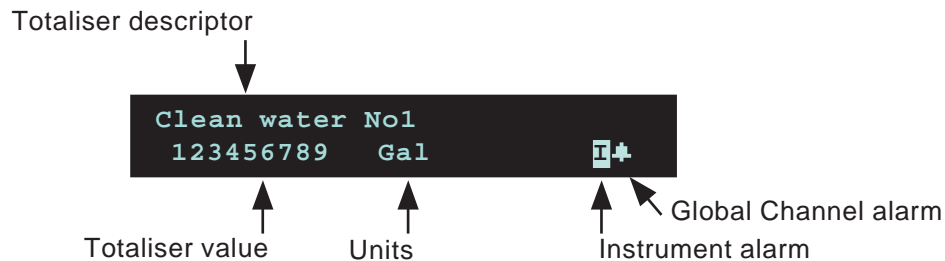

Figure 3.1.2 Totaliser display

### 3.1.3 Alarm information

#### INDIVIDUAL CHANNEL ALARMS

Each input/derived channel can have up to four alarms configured. As shown in figure 3.1.1 above, each alarm has a status icon towards the right-hand end of the top line of the display. These icons can be of one of five types, as shown in table 3.1.3.

The different types are described in 'Alarm Configuration' in section 4.6 of this manual.

|  |                          |
|--|--------------------------|
|  | Absolute high            |
|  | Absolute low             |
|  | Rate-of-change (rising)  |
|  | Rate-of-change (falling) |
|  | Deviation                |

Table 3.1.3  
Alarm symbols

#### GLOBAL ALARM SYMBOL

This bell-like symbol (figure 3.1.1) appears on the lower line of the display if any channel etc. is in an alarm state.

#### INSTRUMENT ALARM

This 'I' symbol in inverse video, appears if any one (or more) of the alarms listed below is active. The alarm may also flash for approximately 5 seconds after initialisation is complete. To view the instrument alarms, the 'Inst Alarms ?' menu item in the Operator Menu (section 3.2) is accessed.

The following messages may appear at the top line of the display, with the word 'Lost' below. For example:

|                      |
|----------------------|
| Input Prog 3<br>Lost |
|----------------------|

- |                |   |
|----------------|---|
| Alarm Prog XY. | This alarm becomes active for any alarm for which configuration data has been lost. 'X' represents the channel associated with the alarm, whilst 'Y' represents the relevant alarm number. E.G. Alarm Prog 13 would mean that there was a problem with the configuration data for alarm 3 on channel 1. See section 4.6, below for alarm configuration details. |
| CJC Cal X      | This alarm becomes active if there is a problem with the Cold Junction Compensation calibration for input board X (where X = 1 or 2). See section 5.2 for calibration details.  |
| Channel Adj X  | Active if channel adjust data for channel X is lost.  |
| Chan Desc X    | This alarm is active if the descriptor data for channel X is lost.  |
| Chan Prog X    | This becomes active if Chart high/low limits have been lost for channel X. See section 4.3 for channel configuration.   |
| Chart Prog     | This alarm becomes active if there is a problem with the pen servo calibration data.  |
| Comms Prog     | Active if there is a problem with the serial communications configuration.  |
| Control Prog X | If controllers are fitted, this alarm becomes active if there is a problem with data for Control loop X (X = 1 or 2). Refer to the Controller manual for details.   |
| Custom Curve   | This becomes active if custom curve data (section 4.5.3) is lost.   |
| DV Prog X      | Active if there is a problem with the configuration data associated with derived channel X. See section 4.4 for derived channel information.  |
| Fact Cal X     | This alarm is active if the factory calibration data for channel X has been lost. If this alarm appears, the recorder supplier should be contacted for advice.  |
| Input Cal X    | This alarm becomes active if calibration data is lost for input channel X. See section 5.1 for channel calibration details.   |
| Input Prog X   | Active if any configuration data (Input Type, Hi/Lo limits, Range Hi/Lo limits, Units and CJC Type) is lost for input channel X. See section 4.3 for channel configuration details.   |
| Misc Prog      | This alarm is active if any item of Instrument configuration (External CJC, Password or Alarm Access) has been lost. See section 4.5 for Instrument configuration.  |
| Relay Prog X   | Active if configuration data for Relay X has been lost.   |
| Retrans Prg X  | This alarm becomes active if configuration data for retransmission channel X has been lost.   |
| Soft Key Prg   | Active if Soft key configuration data (section 4.5.1) has been lost.  |
| Timer Prog X   | The alarm becomes active if configuration data for Timer X (section 4.9) has been lost.   |
| Total Prog X   | The alarm becomes active if configuration data for Totaliser X (section 4.8) has been lost.   |

In addition to these 'Lost' displays, the instrument alarm 'ROM Bad' becomes active if a problem is detected in the recorder software. If this message appears, the recorder supplier should be contacted for advice.

### 3.2 OPERATOR MENUS

The operator menu (figure 3.2) is entered from the normal operating display (the background display) by operating the right arrow key.

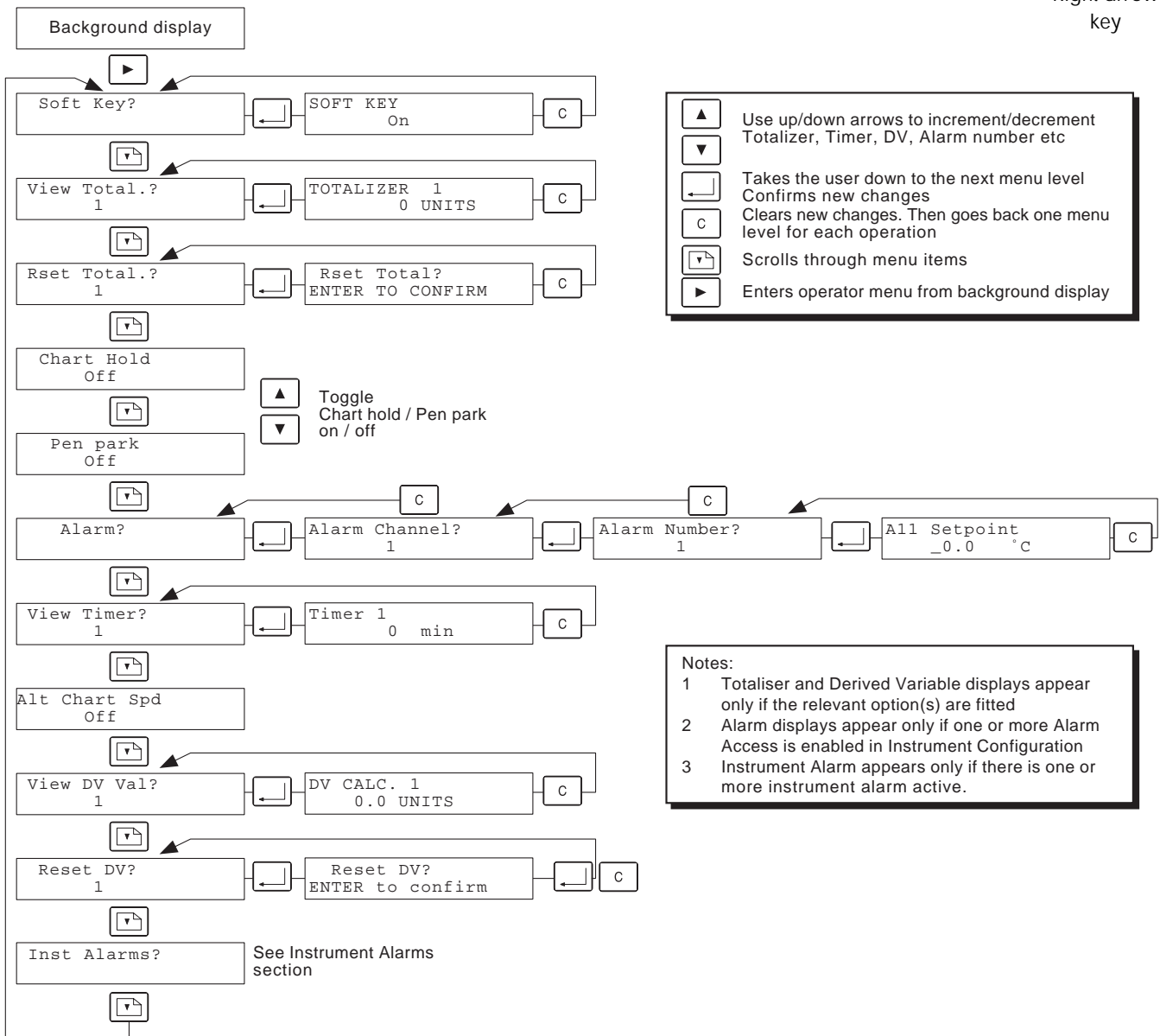

- ▲ Use up/down arrows to increment/decrement Totalizer, Timer, DV, Alarm number etc
- ▼ Takes the user down to the next menu level Confirms new changes
- ← Clears new changes. Then goes back one menu level for each operation
- Scrolls through menu items
- ▶ Enters operator menu from background display

- Notes:
- 1 Totaliser and Derived Variable displays appear only if the relevant option(s) are fitted
  - 2 Alarm displays appear only if one or more Alarm Access is enabled in Instrument Configuration
  - 3 Instrument Alarm appears only if there is one or more instrument alarm active.

Figure 3.2 Operator menu

#### 3.2.1 Operator menu items

##### Soft Key?

This appears only if 'Soft Key' has been enabled in the Instrument Configuration. Operation of the enter key allows the user to set the soft key on or off. When On, the key initiates all action equations (section 4.5.2) which include 'KEY' in their action list, either with a single trigger or continuously, according to action type. For example, a single trigger would be sent for a Totaliser Reset equation, but a continuous on-state is sent to equations such as relay outputs for as long as the softkey is 'On'.

---

### 3.2.1 OPERATOR MENU ITEMS (Cont.)

|              |   |
|--------------|---|
| View Total.? | This menu item appears only if the Totaliser option is fitted. The up/down arrow keys are used to select the required totaliser. The Enter key is then used to display the selected totaliser's value. See <a href="#">section 4.8</a> for totaliser details. |
| Rset Total.? | This menu item appears only if the Totaliser option is fitted. The up/down arrow keys are used to select the required totaliser. The Enter key is then used to reset the selected totaliser.  |

---

Note: The resetting of a totaliser can be used as an input (TTX where X is the totaliser number) to an action equation, and can thus have an effect on the recorder operation.

---

|               |  |
|---------------|--|
| Chart Hold    | The up/down arrow and Enter keys are used to set Chart Hold On or Off. When On, chart rotation is stopped, but pen motion is not. This may eventually lead to the chart becoming worn through.   |
| Pen Park      | The up/down arrow and Enter keys are used to set Pen Park On or Off. When on, the chart is stopped and the pens are lifted from the chart and 'fanned' for easy access during replacement.   |
| Alarm?        | This appears only if 'Alarm Access' is set to 'On' in Instrument configuration. Enter calls the Alarm Channel display:   |
| Alarm Channel | The up/down arrow and Enter keys are used once, to select a channel, then again, to select an alarm number for that channel. Once this has been done, the user can edit the Setpoint value of the selected alarm using the up/down and right arrow keys, followed by Enter. Hysteresis/deadband values cannot be edited from the Operator menu - see section 4.6 |
| View Timer?   | The up/down arrow keys are used to select the required timer. The Enter key is then used to display the selected timer's remaining countdown time. See <a href="#">section 4.9</a> for Timer details   |
| Alt Chart Spd | The up/down arrow keys, followed by "Enter" are used to toggle the alternative chart speed on and off. The alternative chart speed is set up in Instrument configuration (Section 4.5). This operator selection overrides any action equation selections.  |
| View DV Val?  | This appears only if the Maths option is fitted. The up/down arrow keys are used to select the derived channel. The Enter key is then used to display the selected channel's value.  |
| Reset DV Val? | This appears only if the Maths option is fitted. The up/down arrow keys are used to select the derived channel. The Enter key is then used to reset the selected channel's value.  |

## 4 RECORDER CONFIGURATION

### 4.1 INTRODUCTION

The configuration of the recorder is carried out in a number of areas, depending on the options which are fitted. Figure 4.1 shows the top level menu structure, entered from the normal measuring (background) display by using the Page key.

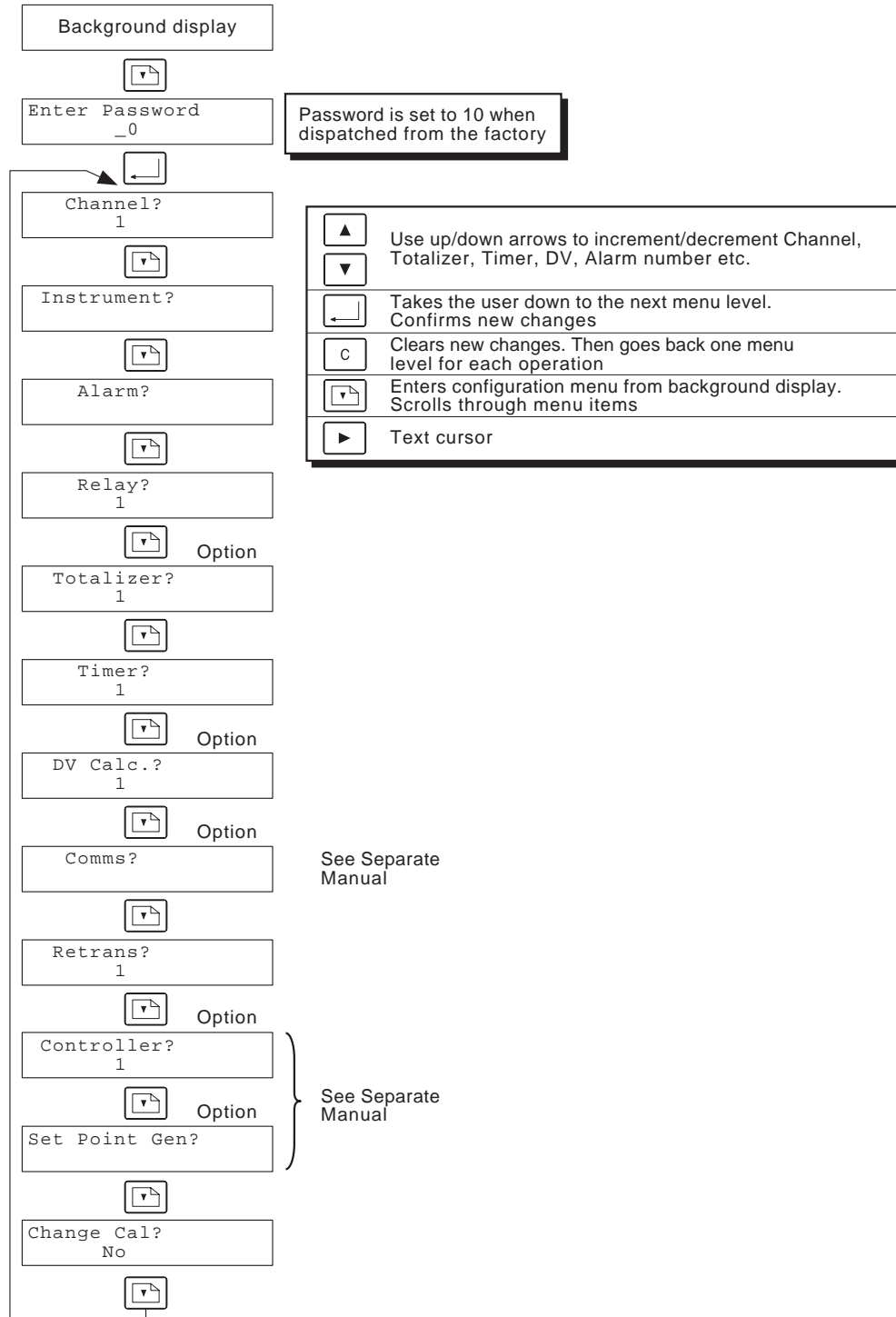

Figure 4.1 Top level configuration menu

## 4.1 CONFIGURATION INTRODUCTION (Cont.)

**Note:** It is not necessary to use any part of the Calibration menu whilst setting up the recorder to measure and record an input. Improper use of Calibration will affect recorder accuracy.

The configuration areas shown in figure 4.1 are each described, in the order in which they appear, in following subsections of this manual.

### 4.1.1 Operator interface

Figure 4.1.1 depicts the operator interface, which consists of a vacuum fluorescent display containing two lines, each of 20 characters, and six navigation keys.

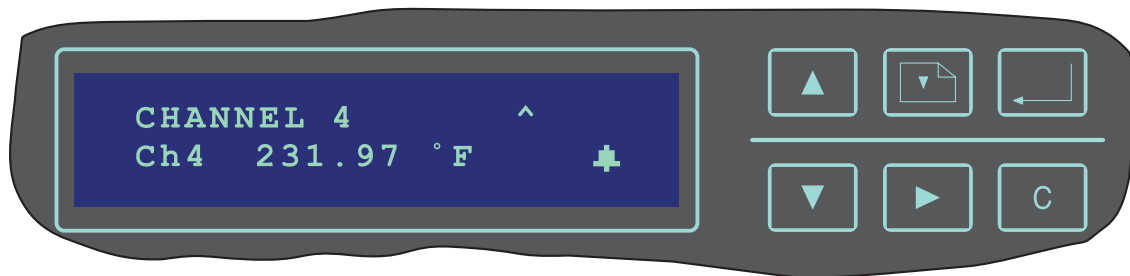







Figure 4.1.1 Operator interface

#### KEY FUNCTIONS

-  Up and down keys.  
 These keys are used to change selections, and to scroll through the character set when entering text strings
- 
-  Page key  
 Used to enter configuration mode and to move between successive menu items
-  Right arrow key  
 This key is used to enter the Operator top level menu ([section 3](#)) and also acts as a cursor whilst entering text strings or numerical values.
-  Enter key  
 Used to move one step down in menu structures, and also to confirm changes.
-  Clear  
 Used to move one step upwards in a menu structure. Also resets any changes that have been made since the last 'Enter'.

#### CONFIGURATION DISPLAY

The basic configuration display format is that the top line contains the configuration item, and the bottom line contains either the current selection of a scroll list of values which are appropriate to that configuration item, or a text or numeric string for editing. Such strings are identified by the cursor symbol displayed to the left of the first character - for example:

```
Pri. Chart Spd
  _24 hr/rv
```

### 4.1.1 OPERATOR INTERFACE (Cont.)

#### ENTRY OF ALPHANUMERIC DATA

The recorder uses a scroll and select method of entry. When a word or number entry is required, a cursor (underscore) is displayed at the left end of the lower line. The right-arrow (cursor) key is used to move the cursor to the character to be edited, and the up and down arrow keys used to scroll through the character set until the required character is reached.

#### CHARACTER SET

The following lists show the available character set. With numeric entries, only numeric characters appear. With text entries, the following characters make up the standard set. The sequence starts with a blank character, and appears in up-arrow sequence:

Space ! " # \$ % & apostrophe ( ) \* + , - . / 0 1 to 9 : ; < = > ? @ A to Z [ \ ] ^ \_ single opening quote { | } ~ Block Space.

The following 'special' characters then appear:

Ä Æ ß É Ñ Ö Û Ü § ç ; € δ ε θ φ π μ ω ∫ Σ ≠ Å <sup>0123456789</sup> √ ± • × ÷ • † ‡ | £ § ≥ √ ♣ ← → ↓ ↑ « » ≪ ≫ 0 1 2 3 4 5 6 7 8 9

before the standard set starts again.

Notes:

- 1 Numeric strings which include spaces will pack (spaces are removed, and the whole string right justified).
- 2 When scrolling through the character set, the scroll speed increases after the sixth character, and again after the 12th character.
- 3 The non-standard character set should not be used in character strings to be sent over the Serial comms link (if fitted). Use of such characters will result in corruption of text strings such as Channel descriptors.

## 4.2 CONFIGURATION ACCESS

Before any configuration changes can be made to the recorder, the Configuration Enable switch must be set to Enable. This switch (SW1) is located on the same circuit board that holds the display (figure 4.2), and is accessible once the door and platen have been opened.

### WARNING

Opening the platen exposes the user to circuitry that may be carrying hazardous voltages. Only qualified service personnel may open the platen whilst hazardous voltages (supply or signal) are connected to the recorder.

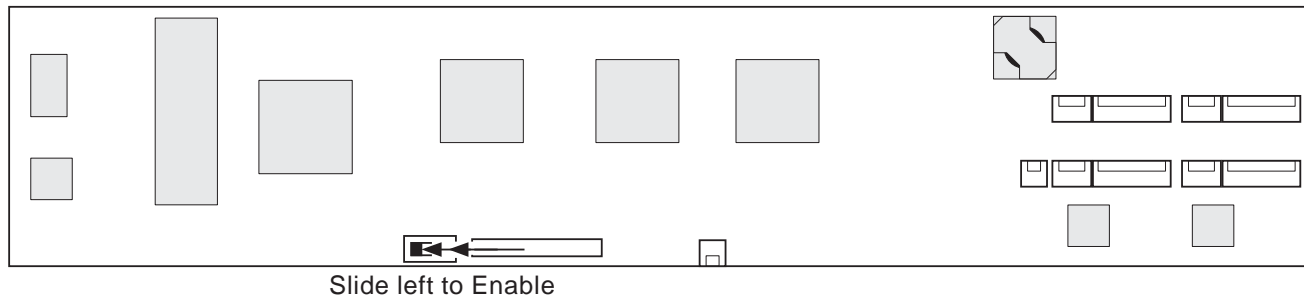

Figure 4.2 Configuration enable switch location

With the recorder in its normal channel value 'background' display, operate the Page key. This calls the password request display:

```
Enter Password
  _0
```

All instruments are shipped with password 10, so, unless the password has been edited (instrument configuration - [section 4.5](#)), operating the Up Arrow key twice, followed by 'Enter' gives access to the first item in the Top-level configuration menu - Channel?. Operating the Page key repeatedly, scrolls through the menu items as shown in [figure 4.1](#) above.

To return to the background display from any point in the configuration process, the Clear (C) key is used as many times as is necessary.

### 4.3 INPUT CHANNEL CONFIGURATION

The Input channel Configuration menu is shown in figure 4.3, below. Note that the menu is context sensitive, so, for example, CJC type appears only if Input Type = thermocouple.

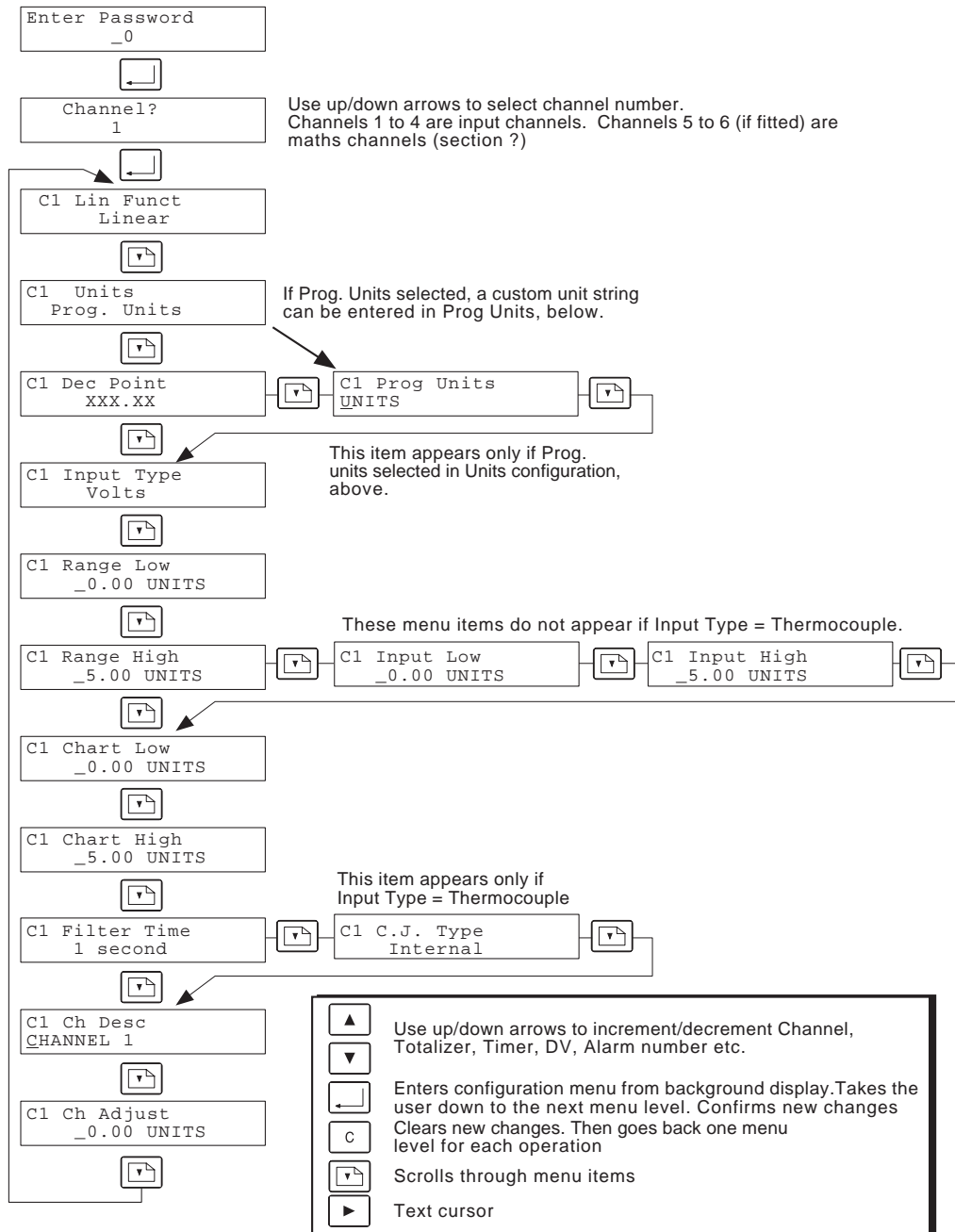

Figure 4.3 Input channel configuration menu structure

### 4.3.1 Configurable items

|                |   |
|----------------|---|
| Lin Funct      | Selectable from:<br>Off, Linear, square root, 3/2 power, 5/2 power. Log <sub>10</sub> , Custom curve, Comms.<br>Thermocouple types: B, C, E, J, K, L, N, Ni/NiMo, R, S, T<br>RTD types: Cu10, Pt100A, PT100D, Ni100, Ni120,   |
| Units          | Select from °C, °F or Programmable units (see Prog Units, below)  |
| Dec.Point      | Use up/down arrow keys to set the number of decimal places (choose none to four). Some thought should be given to this selection, to avoid displaying spurious accuracy, and to avoid rapidly changing numbers that can cause fatigue and confusion.  |
| Prog Units     | This field appears only if 'Prog. Units' was selected in the Units configuration item, above. The up/down/cursor keys are used to enter a units string of up to five characters.  |
| Input type     | Use the up/down arrow keys to select Volts, Millivolts, Ohms or Thermocouple.   |
| Range Low/High | Range Low and high values include the highest and lowest values to be measured in the Engineering units to be used. Range high and low values must be entered for all inputs, to allow the recorder to select the appropriate internal operating range. The recorder will normally operate beyond the specified range values, but the specified recorder accuracy is guaranteed only when the recorder is working within the entered range settings. See table 4.3.1 for details of the recorder's internal ranges. |
| Input Low/High | These fields do not appear for Input type = Thermocouple. Input low/high settings define the electrical input that represents the range inputs entered in Range Low/high configuration. Input values are unnecessary if Input type = Ohms and Lin Funct. is set to one of the RTD tables. The recorder will normally operate beyond the specified input values, but the specified recorder accuracy is guaranteed only when the recorder is working within the entered values.                                      |
| Chart Low/High | These inputs define what part of the input signal is to be represented by chart zero to chart full scale. If Chart Low and High values match the Range Low and High values, then chart zero and chart full scale will match Range Low and Range High respectively.  |
| Filter time    | Input filtering slows the normal zero-to-full scale response of 0.5 second (Filter time = 0) to the selected value of seconds. All functions, including alarm sensing are affected by this filtering.   |
| CJC type       | The cold junction compensation site (where the signal wire changes from thermocouple wire or thermocouple compensation wire to copper) can be defined as internal or external. If external is selected, a temperature for the remote site must be entered in Instrument configuration (Ext CJC Temp) ( <a href="#">section 4.5</a> ).   |
| Ch Desc        | A 16 character (max.) string may be entered here as a channel descriptor to appear in the background display.   |
| Ch Adjust      | In some cases, it might be necessary to adjust the displayed/recorded value to agree with other measurements. For example, Channel adjust can be used to 'zero' an input, such as a load cell, which has a non-zero output for a zero reading. The adjust value is not limited. Positive values add to, and negative values subtract from the measured values.  |

| Input range       | Resolution |
|-------------------|------------|
| - 4 to + 20 mV    | 2 μV       |
| - 12 to + 60 mV   | 6 μV       |
| - 16 to + 80 mV   | 8 μV       |
| - 40 to + 200 mV  | 20 μV      |
| - 80 to + 400 mV  | 40 μV      |
| - 0.34 to + 1.7 V | 170 μV     |
| - 0.5 to + 2.5 V  | 250 μV     |
| - 1 to + 5.0 V    | 500 μV     |

Table 4.3.1 Input ranges and resolutions

## 4.3.2 Examples and application notes

---

### Notes:

1. If Input Type = Millivolts, the Input High value must not be greater than 400mV because the recorder will automatically measure inputs greater than 400mV in Volts, not millivolts. See example 1 below.
  2. For direct thermocouples, set Input type to thermocouple, and select the thermocouple type in Lin. Funct. For indirect thermocouples, set Input type to Volts or Millivolts and select the thermocouple type in Lin. Funct. input Low/High define the actual electrical input.
- 

### EXAMPLE 1: mV RANGING

Input ranges greater than 400mV are always measured using one of the Voltage ranges. Thus, a signal of 250 mV applied to a channel ranged 0 to 500 mV, will display a value of 0.25 units, not 250 units, as might be expected. Further, the resolution of the measured value is lower with a voltage range than it is with a millivolt range (see [table 4.3.1](#), above).

### EXAMPLE 2: MEASURING NEGATIVE VALUES

The negative portion of each input range is 20% of the positive portion. This means that when measuring signals whose negative and positive excursions are equal, a higher range may have to be used. For example, if an input of -1 to +1 Volts is to result in a reading of between -100 and +100, the recorder range must be configured as -100 to +500 with an input range of -1 to +5 Volts.

### EXAMPLE 3: THERMOCOUPLE RANGES

A type J thermocouple range of 0 to 500 °F represents a span of 14.993 mV, causing the recorder to select range 1 (-4 to + 20 mV see [table 4.3.1](#), above). Should the temperature exceed 663 °F (span = 20mV) input range 1 limits are exceeded and the accuracy of the displayed/recorded temperatures will not remain within the specified accuracy.

### EXAMPLE 4: CURRENT LOOP MEASUREMENTS

A transmitter ranged for 0 to 1000 litres/min produces a 4 to 20 mA signal. This is converted to a 1 to 5 Volt signal by a 250Ω shunt across the channel inputs. The channel input values should be set to Input low = 1V; Input high = 5V, Range Low = 0; Range high = 1000, Units = l/min.

### EXAMPLE 5: CHART RANGE

In example 2, only the -100 to +100 portion of the input range is required on the chart. This can be achieved by setting the Chart range low and high values to -100 and +100 respectively.

Similarly, it is possible to compress the input range and trace it on a particular portion of the chart, by setting the chart range greater than the input range. In our example, if the chart range is set to -100 to +500, then the input range of -100 to +100 would be compressed into the 'bottom' 20% of the chart.

## 4.4 DERIVED CHANNEL CONFIGURATION

The Derived channel Configuration menu is shown in figure 4.4, below. Derived channels (if fitted) are channels 5 and 6, and are used to display the values of Derived Variable calculations. It is also possible to allocate a pen to each derived channel, so the computed values may be traced on the chart.

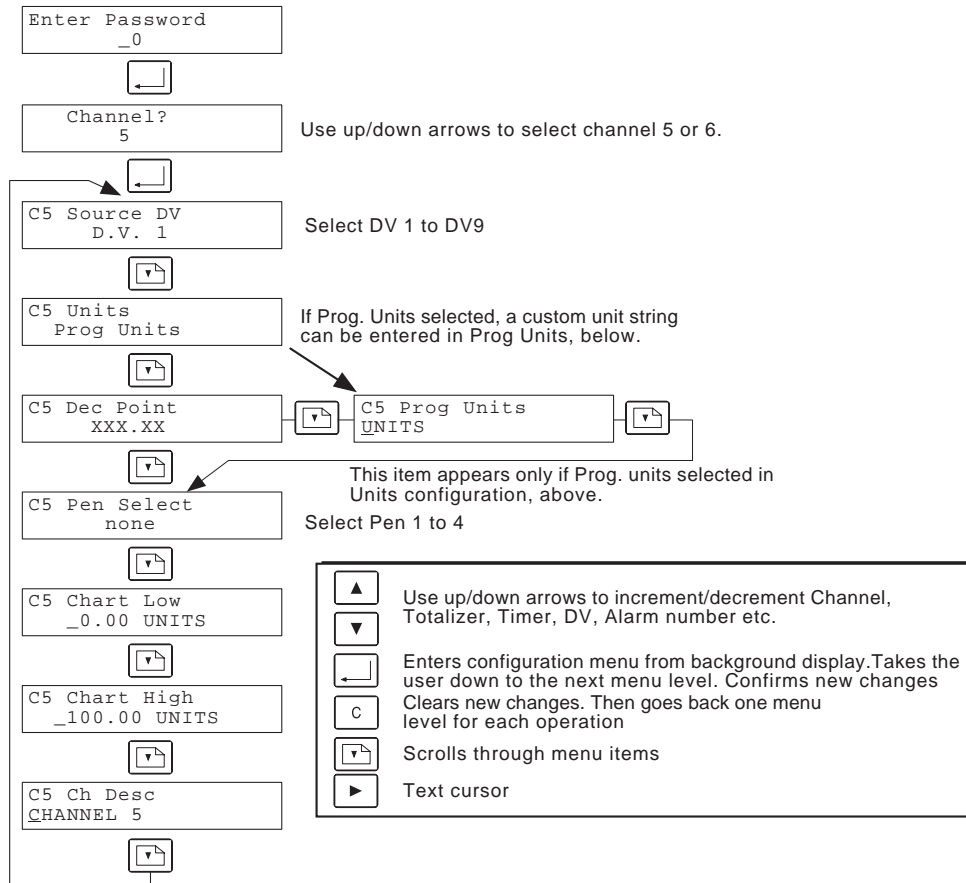

Figure 4.4 Derived channel configuration menu structure

### 4.4.1 Configurable items

|                |  |
|----------------|--|
| Source DV      | Select DV1 to DV9 as the channel source  |
| Units          | Select from °C, °F or Programmable units (see Prog Units, below)   |
| Dec.Point      | Use up/down arrow keys to set the number of decimal places (choose none to four). Some thought should be given to this selection, to avoid displaying spurious accuracy, and to avoid rapidly changing numbers that can cause confusion.                           |
| Prog Units     | This field appears only if 'Prog. Units' was selected in the Units configuration item, above.  |
| Pen Select     | The up/down/cursor keys are used to enter a units string of up to five characters.   |
| Chart Low/High | Select none, or pens 1 to 4 for chart trace.   |
| Chart Low/High | These inputs define what part of the input signal is to be represented by chart zero to chart full scale. If Chart Low and High values match the Range Low and High values, then chart zero and chart full scale will match Range Low and Range High respectively. |
| Ch Desc        | A 16 character (max.) string may be entered here as a channel descriptor to appear in the background display.  |

## 4.5 INSTRUMENT CONFIGURATION

Figure 4.5 shows the instrument configuration items. For the sake of clarity, the Custom Curve menu items have been drawn separately, and appear as [figure 4.5.3](#).

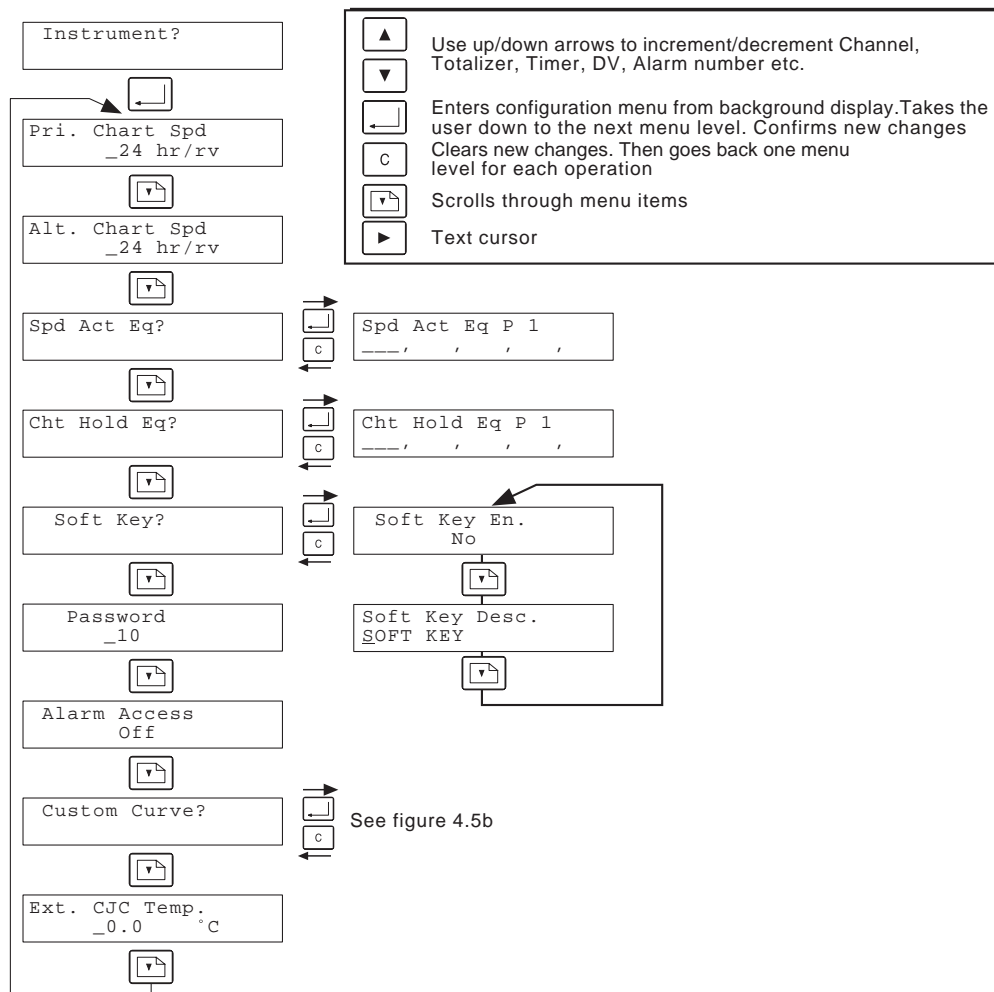

Figure 4.5 Instrument Configuration menu

### 4.5.1 Configurable parameters

- Pri Chart Spd                      Allows the user to enter a chart speed of between 1 and 4096 hours/rev. in increments of 1 hour, to be used as the normal chart speed.
- Alt. Chart Spd                     Allows the user to enter a chart speed of between 1 and 4096 hours/rev. in increments of 1 hour, to be used as an alternative chart speed for use whenever the Chart Speed action equation becomes active.
- Spd Act Eq                         Enter allows the user to define a number of internal triggers, which if any one of them is 'true', changes the speed of the chart from the primary chart speed to the alternative chart speed. The items are entered from a scroll list. See section 4.5.2 for a description of the scroll list.
- Cht Hold Eq                        Enter allows the user to define a number of internal triggers, which if any one of them is 'true', stops the chart. The items are entered from a scroll list. See section 4.5.2 for a description of the scroll list.
- Soft Key                            Enter allows the Soft Key to be enabled/disabled. When enabled, the Soft Key appears in the Operator menu (section 3). The Soft Key is an internal trigger which appears in the Action equation scroll list (KEY). Operation of the Page key allows a descriptor for the Soft Key to be entered.

#### 4.5.1 INSTRUMENT PARAMETERS (Cont.)

|              |   |
|--------------|---|
| Password     | As shipped, the instrument password is 10. This can be edited here, permissible entries being 1 to 127. Access to the configuration menus is not possible without this password.  |
| Alarm Access | This setting determines whether or not an operator can access alarm information from the Operator Menu (section 3). If access is 'On', alarm setpoints can be edited from the Operator menu. If access is 'Off', alarm menu items do not appear in the Operator menu.                             |
| Custom Curve | This allows a user generated linearisation table to be entered as a number of segments, as described in <a href="#">section 4.5.3</a> , below. This linearisation table appears in the list of Functions in Channel 'Lin Funct' configuration described in <a href="#">section 4.3.1</a> , above. |
| Ext CJC Temp | If CJC type is set to 'External', for any channel ( <a href="#">section 4.3.1</a> above), the temperature at which the external CJC is maintained is entered here.  |

#### 4.5.2 Action Equations

Many of the standard and optional features of the recorder can be reset, started, stopped etc. in response to internal triggers, or external (contact closure) events. The list of triggers, as they appear in the (up arrow) scroll list, is as follows:

|              |   |
|--------------|---|
| C11 to C18   | Event input                                   |
| C21 to C28   | Event input                                   |
| TT1 to TT4   | Totaliser reaching its preset value           |
| D1H/L, D2H/L | Controller deviation alarms                   |
| A11 to A64   | Alarms Channel 1 Alarm 1 to Channel 6 Alarm 4 |
| SP1 to SP8   | Setpoint generator events 1 to 8              |
| COM          | Trigger settable via the Comms port           |
| KEY          | Soft Key set 'On' by the operator             |
| INA          | Instrument alarm                              |
| GLA          | Global alarm                                  |
| TM1 to TM4   | Timer 1 to Timer 4 reaching its preset time   |

##### Notes

- 1 The above list includes all options. If an option is not fitted then its triggers do not appear in the scroll list.
- 2 Soft Key operation is context sensitive, and will either result in a single trigger or a continuous state change depending on the action equation.

The action equation is a 'Logical OR' of all the triggers included in the equation. The number of triggers is unlimited, and if there are more than can be include in one page, the page key can be operated to go to the next page. (The enter key might need to be operated before progressing to further pages when adding new triggers in configuration mode.)

#### ACTION EQUATION EXAMPLE

The following entries would be made to cause the chart speed to change to the alternative chart speed when one or more of the following triggers is active:

Alarm 1 on channel 1; Alarm 2 on channel 2, Alarm 1 on channel 3, Softkey 'On'.

Spd Act Eq? P1  
A11 , A22 , A31 , KEY

### 4.5.3 Custom curve

A custom curve is defined by five segments, each of three points, where the third point of one segment is also the first point of the next segment. Thus, segment one consists of points one, two and three; segment two of points three, four and five, segment three of points five, six and seven, and so on, up to point 11. A 3rd order polynomial fit is then applied to the 11 points.

Each point is defined as a pair of values (a point pair) consisting of the signal input value, and an associated % value as shown in the example below. Because the curve can be used as the linearisation function for any input channel, percentage of full scale is used, rather than specific units.

Figure 4.5.3 shows the configuration menu.

**Note:** Value must be entered for all eleven point pairs, otherwise the polynomial fit will not be accurate. If a fewer number of segments are required, then imaginary values must be entered for the unused points. Values for these 'spare' points must always increase.

#### EXAMPLE

A particular linearisation curve (defined by the user) is to be made up of three segments (points 1 to 7). The signal value for point 1 is 4.0 mA (= 0%); the full scale value (point 7) is 20 mA (100 %). These values are converted to a signal range of 1 to 5 Volts by a 250Ω shunt across the channel input. The point pair data is as listed in the table below:

|                | Input (ma) | Input V | Units % | Segment number(s) | Point pair |
|----------------|------------|---------|---------|-------------------|------------|
| Defined points | 4.0        | 1.000   | 0.00    | 1                 | 1          |
|                | 4.5        | 1.125   | 2.22    | 1                 | 2          |
|                | 5.0        | 1.250   | 6.67    | 1 2               | 3          |
|                | 5.5        | 1.375   | 11.11   | 2                 | 4          |
|                | 6.0        | 1.500   | 20.00   | 2 3               | 5          |
|                | 13.0       | 3.250   | 60.00   | 3                 | 6          |
|                | 20.00      | 5.000   | 100.0   | 3 4               | 7          |
| Added points   | N/A        | 6.000   | 200.0   | 4                 | 8          |
|                | N/A        | 7.000   | 300.0   | 4 5               | 9          |
|                | N/A        | 8.000   | 400.0   | 5                 | 10         |
|                | N/A        | 9.000   | 500.0   | 5                 | 11         |

Table 4.5.3 Custom curve entry example

4.5.3 CUSTOM CURVE (Cont.)

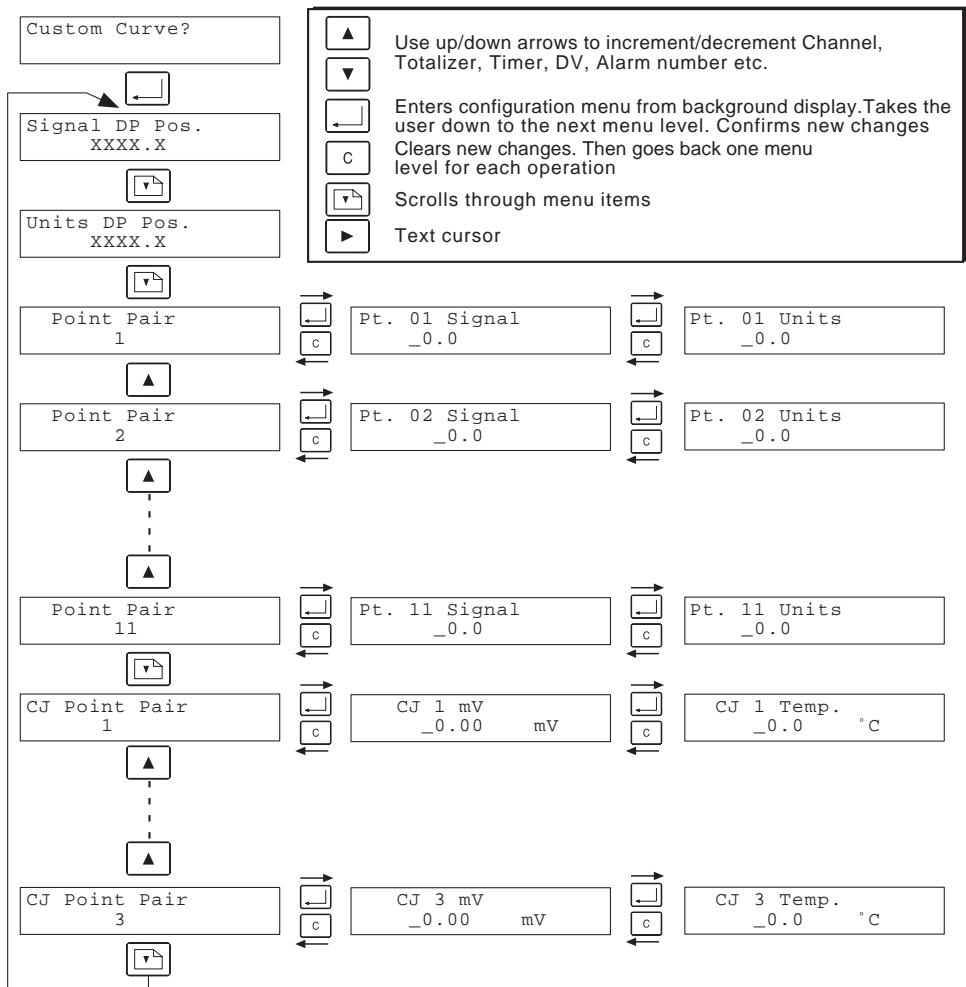

Figure 4.5.3 Custom curve configuration menu

**CONFIGURABLE ITEMS**

- Signal DP Pos      Allows the number of decimal places to be chosen for the input signal
- Unit DP Pos        Allows the number of decimal places to be chosen for the curve units input
- Point pair         Allows 11 point pairs to be defined as described in the example above. ALL 11 sets MUST BE ENTERED, whether used or not.
- CJ point pair      Use the up/down arrow keys to select 1, 2 or 3, then 'Enter to call the CJX mV menu item:
- CJX mV             Used only if the Input Type for the channel running the custom curve is set to 'Thermocouple'. Allows entry of the millivolt equivalents of the lowest (CJ1), midpoint (CJ2) and highest (CJ3) ambient temperatures that the recorder is likely to be subjected to, whilst using the custom curve entered above, according to the thermocouple type being used. The Page key calls 'CJ1 Temp' menu item:
- CJX Temp          Used only if the Input Type for the channel running the custom curve is set to 'Thermocouple'. Allows entry of the Celsius values of the lowest (CJ1), midpoint (CJ2) and highest (CJ3) ambient temperatures that the recorder is likely to be subjected to, whilst using the custom curve entered above. These values must be the same as their millivolt equivalents entered in the CJ mV pages.

## 4.6 ALARM CONFIGURATION

Figure 4.6 shows the configuration menu for alarms. Up to four alarms can be defined for each channel. The figure shows the three types of alarm - Absolute (High, Low), Deadband and Rate-of-change (Rate - Rising / Rate - Falling).

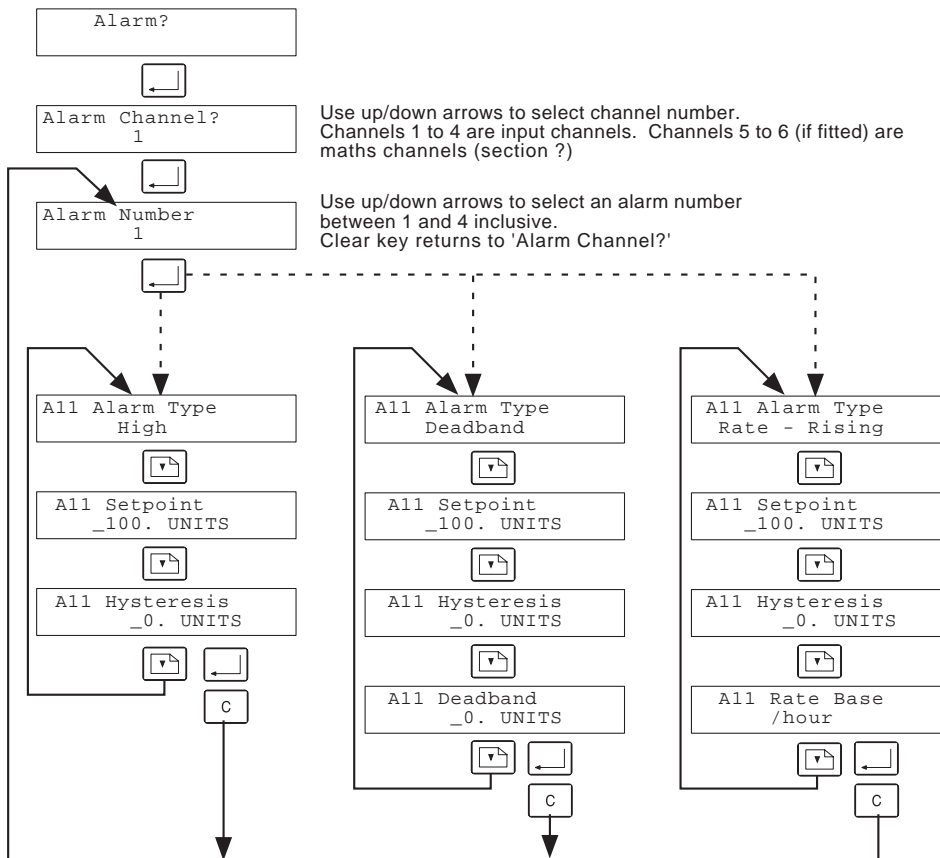

Figure 4.6 Alarm configuration menu

### 4.6.1 Alarm Types

For the purposes of this document, alarms are described as being of three types - Absolute, Deadband and Rate-of-Change.

#### ABSOLUTE ALARMS

Absolute High alarms become active when the measured value exceeds the Setpoint value, and remain active until the Measured value falls below the value given by (Setpoint - Hysteresis).

Absolute Low alarms become active when the measured value falls below the Setpoint value, and remain active until the Measured value rises above the value given by (Setpoint + Hysteresis).

#### DEADBAND ALARMS

A deadband alarm is active:

- 1 If the measured value rises above the value given by (Setpoint + Deadband). In this case, the alarm remains active until the measured value falls below the value (Setpoint + Deadband - Hysteresis)
- 2 If the measured value falls below the value given by (Setpoint - Deadband). In this case the alarm remains active until the measured value rises above the value (Setpoint - Deadband + Hysteresis).

### 4.6.1 ALARM TYPES (Cont.)

#### RATE OF CHANGE ALARMS

Rate-Rising alarms become active if the measured value increases by more than the Setpoint within the specified unit time (Rate Base). Such alarms remain active until the rate of change falls below (Setpoint - Hysteresis) per unit time. Rate- Falling alarms become active if the measured value decreases by more than the Setpoint within the specified unit time (Rate Base). Such alarms remain active until the rate of change rises above (Setpoint + Hysteresis) per unit time. A filter setting of 1 second is recommended for use with rate of change alarms. Without filtering, step changes may prove too fast for the recorder to measure a rate. With larger values of filter time, the input signal may be slowed too much for the alarm to be useful.

#### EXAMPLE 1: RATE OF CHANGE ALARMS

When a large piece of rotating machinery is 'cold started', it is important to know if any of the bearings are overheating. An absolute high alarm is not always adequate, because by the time the bearing has tripped the alarm the damage may already have been done. A rate-rising alarm can detect any unusually rapid rise in temperature, and give warning of impending failure.

#### EXAMPLE 2: HYSTERESIS

Hysteresis is used to ensure nuisance trips are filtered out from situations where the measured value is hovering about the setpoint value. For example, an absolute high alarm set to 450 °C becomes active at 450 °C and returns to an inactive state at 449.9 °C. This leads to the alarm rapidly going on and off if the temperature is hovering at 450 °C. This situation can be remedied by introducing a hysteresis value of (say) 10 °C, so the alarm still becomes active at 450 °C but remains active until the temperature falls below 440 °C

### 4.6.2 Configurable items

|               |  |
|---------------|--|
| Alarm channel | The up/down arrow keys, then 'Enter' are used to select the required channel   |
| Alarm number  | The up/down arrow keys, then 'Enter' are used to select the required alarm number  |
| Alarm type    | Select Alarm type from scroll list (see section 4.6.1, above).   |
| Setpoint      | The trip value for absolute and rate-of-change alarms, or the centre value for deadband alarms.  |
| Hysteresis    | Used to eliminate nuisance trips if the measured value hovers near the trip point .  |
| Deadband      | The value which lies each side of the setpoint in Deadband alarms. Alarm is active if the measured value lies outside the band defined by (Setpoint $\pm$ deadband). I.E. Total width of the non-active area = twice Deadband entry. |
| Rate Base     | For rate-of-change alarms only, this defines the unit time within which the measured value may not change by more than the Setpoint value. Select from: per hour, per minute, per second.  |

### 4.7 RELAY OPTION CONFIGURATION

Figure 4.7, shows configuration menus for the different relay ‘Types’ that can be selected.

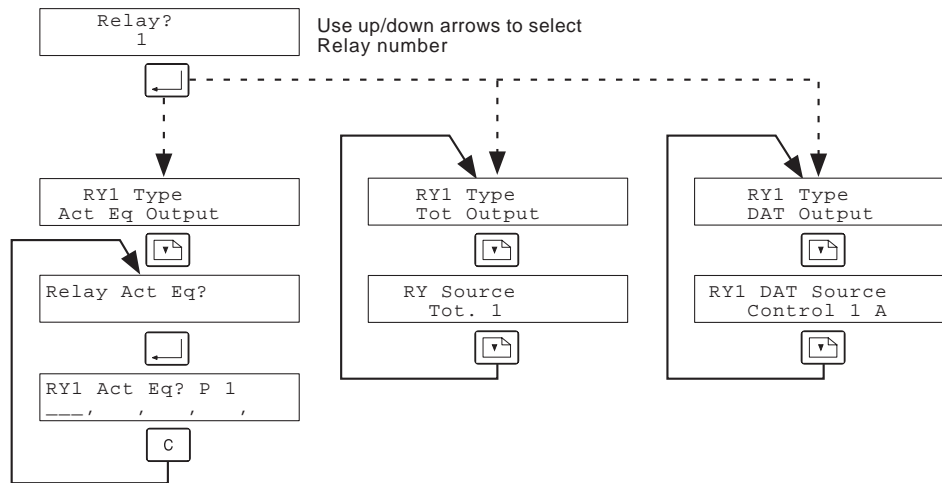

Figure 4.7 Relay Configuration pages

#### 4.7.1 Configurable items

|              |  |
|--------------|--|
| Relay Number | There can be up to two relay boards, each containing up to four relays. Board 1 contains relays 1 to 4; board 2 contains relays 5 to 8, as shown in figure 4.7.1 below. Where board two is fitted, it is always fitted above board 1. Board number is automatically determined by the recorder. (Note 3) |
| Relay Type   | This refers to how the relay is switched on and off as follows:  |
| Off          | The relay is not used  |
| Act Eq       | The specified relay is operated by action equation (see section 4.5.2 for details).  |
| Tot X        | The relay is operated by a totaliser output signal - see section 4.8   |
| Dat Output   | The relay is operated by an output from controller 1 or 2 - see separate manual.   |

Notes:

- 1 Fail-safe operation  
Relays which are specified as ‘Off’ are always energised (common to normally open)  
Action equation and totaliser operated relays are normally energised (common to normally open), but de-energise (common to normally closed) when their driving source becomes active.  
DAT operated relays are normally de-energised (common to normally closed) and are energised (common to normally open) during the ON part of the cycle.
- 2 Relays are SPDT (single pole double throw) form C. For ratings see specification in Annex A.
- 3 On previous models, board number was defined by a link on the board, set to either Brd 1 or Brd 2.

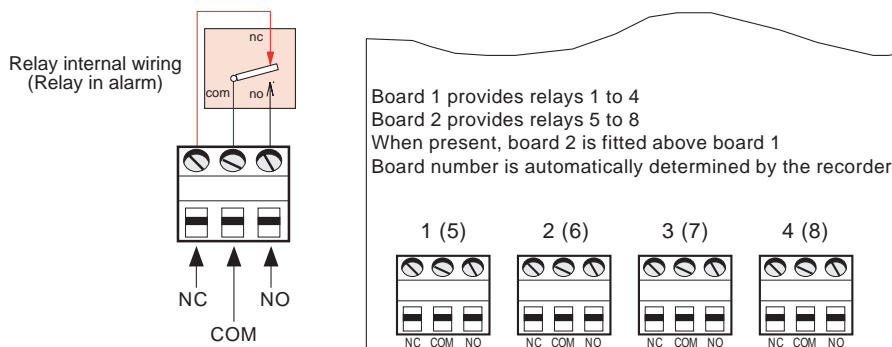

Figure 4.7.1 Relay board details

## 4.8 TOTALISER OPTION CONFIGURATION

A totaliser is an electronic integrator, primarily used to record a numeric total, over time, of a measured value that is expressed as a rate (e.g. the number of cubic metres since last reset, based on a flow rate of cubic metres per hour).

The totaliser function reads the numeric input from its source once a second. This reading is divided by the totaliser factor and added to the total. The totaliser factor is normally the number of seconds in the measured value's time base. Thus, for example, if the input is in cubic metres per hour, the totaliser factor would have to be the number of seconds in an hour = 3600.

Totalisers can also be configured to count contact closures at a maximum rate of 8 per second.

A further option (Counter output) allows an output relay to 'retransmit' totaliser counts with a 50 msec. closure for each count. Outputs can be one-to-one with inputs, or can be divided by a scaling value (e.g. one output count for every 1000 totaliser counts).

---

*Note: During power off conditions, totaliser values are retained for 100 hours by a 'super cap' on the CPU board.*

---

Figure 4.8 shows the totaliser menu structure, including the counter output option.

### 4.8.1 Factor Entry

For totalisers with channel sources, the factor is entered in terms of the time base of the source channel in seconds. If the source is a contact closure, the factor defines a ratio of input counts: displayed counts. In either case, the factor is entered as two parts, the mantissa (Man) and the exponent (Exp).

For example 1760 can be expressed as  $1.760 \times 1000$  or  $1.760 \times 10^3$ . In this case the mantissa is 1.760 and the exponent is 3. 1769000 can be expressed as  $1.769 \times 1000000$  or  $1.769 \times 10^6$ . In this case, the mantissa is 1.769 and the exponent is 6. An exponent of 0 means multiply by 1.

### SCALING

Because the display has only five characters, source values that would normally be expressed in more than five digits (e.g. 0 to 3,000,000 litres/day) must be ranged as a ratio of that number (e.g. 0 to 3000 with a description of litres/day  $\times$  1,000). The totaliser will then count in steps of 1,000 gallons, so that 3,000,000 gallons would add 3,000 counts.

To make the totaliser count more slowly, the exponent can be altered. For example, directly totalising 30,000 litres/minute (Factor = 60 =  $6.0000 \times 10^1$ ) would add 43,200,000 counts per day. This would overflow the totaliser in 23 days. If the factor were changed so that the readings were not in litres, but in thousands of litres, (i.e. by changing the exponent from  $10^1$  (exp = 1) to  $10^4$  (exp = 4)), only 43,200 counts would be added each day and the totaliser would take over 60 years to overflow.

---

*Note: If a source is ranged 0.0 to 3.0 and the totaliser is scaled up by a 1000, each change in the least significant digit (LSD) represents 100 counts, with a potentially large rounding error. If the Source's range is set to 0.000 to 3.000, each change in the LSD represents only 1 count.*

---

It is also possible to make the totaliser count faster than the rate being received from the source. E.G. to make the count 10 times faster, reduce the exponent by 1; to make it 100 times faster, reduce the exponent by 2.



**4.8.2 TOTALISER CONFIGURABLE ITEMS (Cont.)**

Note: Any change in the configuration of a totaliser resets that totaliser.

|                  |   |
|------------------|---|
| Totaliser number | The up and down arrow keys and the Enter key are used to select a totaliser for configuration   |
| Type             | Select Off, Continuous, Preset up/down or Preload   |
| Off              | The totaliser is disabled   |
| Continuous       | Totaliser value increases continuously unless reset by the operator or by action equation. Totaliser value returns to zero and starts again after 999,999,999 counts have been exceeded.  |
| Preset up/down   | A Preset Up totaliser counts up to the Preset value. When this value is reached the totaliser stops and an internal trigger is set for use in action equations. A preset down totaliser counts to zero from the preset value. When zero is reached the totaliser stops and an internal trigger is set for use in action equations. The totaliser reset equation can be used to reset the totaliser as a result of such a trigger. |
| Preload          | This type of totaliser is a continuous totaliser that restarts from a user-entered value (Preload). Useful when totalising must be paused for some reason, and then restarted from a known value.   |
| Source           | The up and down arrow keys and the Enter key are used to select an input or derived channel, or a contact closure source.   |
| Factor           | Enter the mantissa and exponent for the totaliser scaling as described in <a href="#">section 4.8.1</a> . Table 4.8.2 contains some commonly used factors.  |
| Units            | Enter a string of up to 5 characters to describe the totalised units.   |
| Preset           | For preset and preload totalisers only, enter the preset/preload value here.  |
| Low/Hi cutoff    | Allows the user to set values below which and above which the totaliser will not totalise. The default High cut off value is 'Overrange', and all five of the caret (^) symbols must be replaced or deleted if a different value is entered.  |
| Resettable       | The up/down arrow keys are used to select the totaliser as resettable or not. When set to 'Yes', the totaliser can be reset by the operator (section 3), or by action equation. When set to 'No', the totaliser all requests to reset the totaliser are ignored.  |
| Rset Eq          | Allows the totaliser reset equation to be set up. - See <a href="#">section 4.5.2</a> for a description of action equations.  |
| Hold Eq          | Allows the totaliser hold equation to be set up. - See <a href="#">section 4.5.2</a> for a description of action equations.   |
| Cntr. Out        | When selected on, this option outputs a trigger every time a specifiable number of counts has been added to the totaliser value. This trigger can be used to operate a relay.   |
| Out Fact         | 'Enter' allows the ratio between totaliser counts and output counter triggers to be set. For example, a factor of 1 (1.0000 x 10 <sup>0</sup> ) means that there is a trigger every time the totaliser value changes; a factor of 10 (1.000 x 10 <sup>1</sup> ) means that there is one trigger for every 10 totaliser counts, and so on. See <a href="#">section 4.8.1</a> for details of factor entry.                          |
| Tot Desc.        | Allows a descriptor for the totaliser to be entered.  |

|          | Seconds | Mantissa | Exp |
|----------|---------|----------|-----|
| Per sec  | 1       | 1.0000   | 0   |
| Per min  | 60      | 6.0000   | 1   |
| per hour | 3600    | 3.6000   | 3   |
| Per day  | 86400   | 8.6400   | 4   |

Table 4.8.2 Common totaliser factors

## 4.9 TIMER CONFIGURATION

There are four internal timers which can be set to count down from a preset number of minutes. When this time has elapsed, the timer sets an internal trigger (TM1 to TM4). The timer starts when reset through its reset equation. If the timer output trigger is used as a source for the reset action equation, then the timer becomes a repeating interval timer.

### Notes

1. Because of the iteration rate of the recorder, there is a delay of approximately one second between a counter's reaching zero and it restarting.
2. After power losses of up to a few seconds, timers reset to zero. After longer periods without power, timers restart their count from the entered number of minutes (Duration).

Figure 4.9 shows the menu structure.

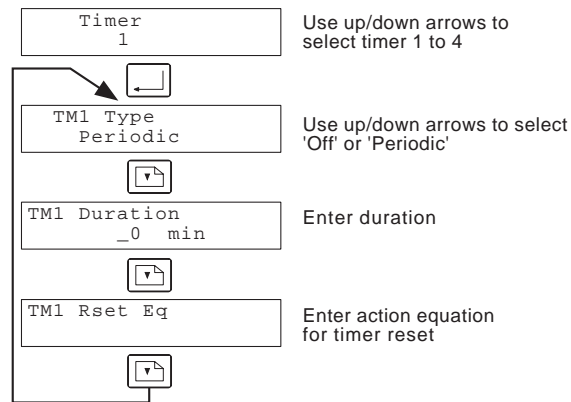

Figure 4.9 Timer configuration menu

### 4.9.1 Configurable items

|          |  |
|----------|--|
| Type     | Select Off or Periodic. Periodic timers output a trigger after counting down from the operator entered Duration (number of minutes).         |
| Duration | Allows the user to set the count-down time to between 1 and 999,999,999 minutes.   |
| Rset Eq  | Allows the action equation triggers to be entered for starting the timer. See <a href="#">section 4.5.2</a> for details of action equations. |

## 4.10 DERIVED VARIABLES

### 4.10.1 Introduction

This feature provides basic and specialised maths functions. Each recorder may have one or two optional derived channels which are displayed as channels 5 and 6. There are a total of nine derived variable which can be used by either or both derived channels.

A derived channel can be traced on the chart by assigning a pen to it in its configuration ([section 4.4](#)). The channel from which the pen is 'taken' continues to act as configured (i.e. its value is still displayed, alarms still acted on, it can still be totalised etc.), but it does not appear on the chart.

Although the results of only two calculations can be assigned to channels - and therefore appear in the normal background scrolling of channel values - the values of all Derived Variables (DVs) can be viewed from the operator manu ([section 3](#))

### AVAILABLE MATHS FUNCTIONS

The following is a list of the available maths functions.

#### 'BASIC' FUNCTIONS

| Function    | Equation                                      |
|-------------|---|
| Add         | $A + B$                                       |
| Subtract    | $A - B$                                       |
| Divide      | $A \div B$                                    |
| Multiply    | $A \times B$                                  |
| Lin. Slope  | $(A \times B) + C$                            |
| High Select | If $A > B$ , then use A                       |
| Low Select  | If $A > B$ , then use B                       |
| High Peak*  | Highest value since reset                     |
| Low Peak*   | Lowest value since reset                      |
| Average*    | Single point average - cumulative since reset |
| Polynomial  | $A_0 + A_1x + A_2x^2 + A_3x^3$                |

#### 'SPECIALISED' FUNCTIONS

|              |  |
|--------------|--|
| Log 10       | $B \log_{10} x$  |
| Power 10     | $AB \times 10^x$   |
| Flow, Sq.Rt. | Mass flow (square root) - <a href="#">see section 4.10.2</a>                           |
| Flow, Linr.  | Mass flow (linear) - <a href="#">see section 4.10.2</a>                                |
| F Value*     | Sterilization constant ( $F_0$ value since reset) - <a href="#">see section 4.10.2</a> |
| RH           | Relative Humidity - <a href="#">see section 4.10.2</a>                                 |
| ZrO2 Sensor  | Zirconia $O_2$ probe - <a href="#">see section 4.10.2</a>                              |

#### Notes:

1. Because of processing time allocations, a maximum of two specialised functions may be running at any one time.
2. DV calculations work in Engineering units. For example, If a 4 to 20 mA input is converted to 1 to 5 Volts at the channel input and scaled 0 to 400 Bar, any DV calculation with this channel as a source will return a value in Bar.
3. Functions marked with an asterisk (\*) have their values retained for 100 hours, under power off conditions, by a supercap located on the CPU board.

### 4.10.2 Configuration

Fig 4.10.2 shows a generalised version of Derived Variable configuration. As indicated, the number of inputs varies from function to function, and wherever possible, the inputs are given names to identify them. The functions are fully described in the subsections below.

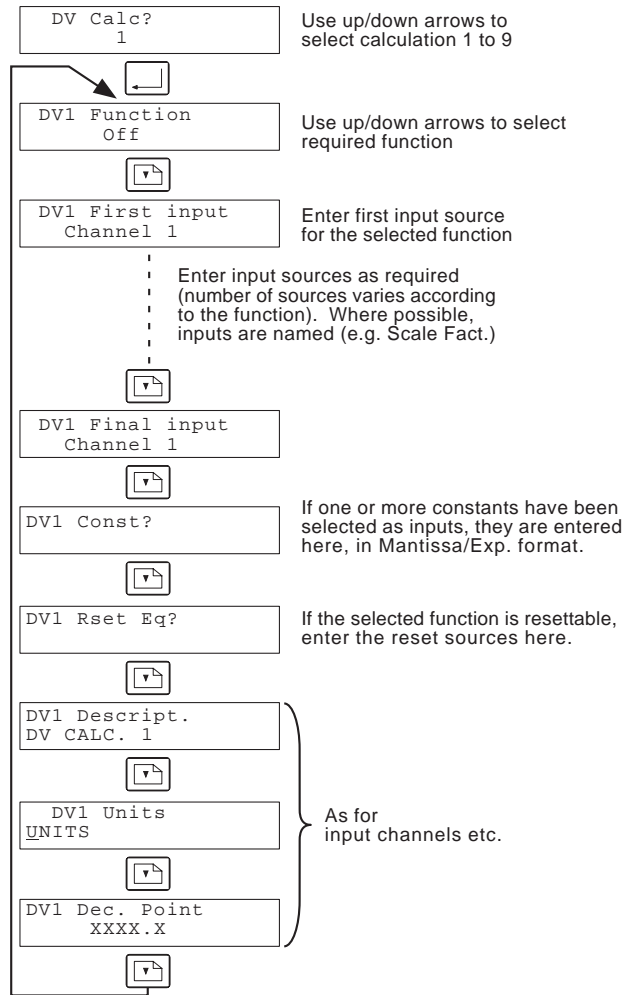

Figure 4.10.2 Derived Variable Menu structure

#### FUNCTION DETAILS

|             |  |
|-------------|--|
| Add         | Adds Input 1 and Input 2   |
| Subtract    | Subtracts Input 2 (Subtractor) from Input 1  |
| Divide      | Divides Input 1 (Numerator) by Input 2 (Denominatr). If Denominatr = 0, output = 99999   |
| Multiply    | Multiplies Input 1 by Input 2.   |
| Lin. Slope  | Calculates the function $y = ax + b$ , where the variable $x$ is Input 1, 'a' is Input 2 (Slope) and 'b' is Input 3 (Offset). Slope and offset should be set to 'Constant', and their values entered in the 'DVx Constant?' part of the configuration. |
| High Select | The output from the function copies whichever is the higher of Input 1 and Input 2   |
| Low Select  | The output from the function copies whichever is the lower of Input 1 and Input 2  |
| High Peak   | The output is the highest value that Input 1 has reached since last reset. The value is retained under power down conditions.  |
| Low Peak    | The output is the lowest value that Input 1 has reached since last reset. The value is retained under power down conditions.   |

**4.10.2 MATHS FUNCTION CONFIGURATION (Cont.)**

**Average** The cumulative average value of Input 1 (Input), with samples taken every Input 2 (Sec/ Sample) seconds. Each sample is added to the previous total, and the result is divided by the total number of samples.

Minimum sample period = 5 secs; maximum sample rate = 32,767 seconds  
 Maximum number of samples = 65536 (= 91 hours at 5 Sec/Sample). After this, the value is replaced by the current value, and the averaging starts again.  
 When reset, the output goes to the current value, and averaging restarts.

**Polynomial** Calculates the equation  $y = A_0 + A_1x + A_2x^2 + A_3x^3$ , where x is a variable and A0 to A3 are constants.  
 Input 1 (Input) is the variable. The remaining inputs (A0 to A3) are each set to 'Constant', and their values entered in the 'DVx Constant?' configuration.

**Log<sub>10</sub>** Solves the equation  $y = A \log_{10}x$  (where A is a 'scaling factor'). If  $x = 0$ ,  $y = -99999$

**Power 10** Solves the equation  $y = A \cdot 10^x$  (where A is a 'Scaling factor'). If  $x > 30$  or  $x < -30$ ,  $y = 0000.0$

**Flow, Sq.Rt.** Basic AGA3 Gas flow. Solves the equation:

$$QM_t = \sqrt{A} \times \sqrt{\frac{\text{Delta}P_t \times \text{Abs}P_t}{\text{Temp}_t \times Z}}$$

where:  $QM_t$  = Mass flow, at time t (in the same units as the measured flow, below).  
 A = Measured flow x Scaling factor  
 Delta $P_t$  = the differential pressure (inches of water) at time t  
 Abs $P_t$  = The absolute pressure (Static Pressure) in PSI(A) at time t  
 Temp $P_t$  = The flow temperature in degrees Rankine  
 Z = Compressibility factor

Notes:

1. Differential pressure input can be a constant, if the channel uses sq. root to measure raw flow.
2.  $PSI(A) = PSI(G) + 14.7$
3.  $^{\circ}R = (^{\circ}F + 459.67)$  or  $\{(1.8 \times ^{\circ}C) + 491.67\}$

**Flow, Linr.** Linear AGA3 Gas flow. Solves the equation

$$QM_t = A \times \frac{\text{Flow}_t \times \text{Abs}P_t}{\text{Temp}_t \times Z}$$

where:  $QM_t$  = Mass flow at time t (in flow meter units).  
 A = Scaling factor  
 Flow $t$  = Output from flow meter  
 Abs $P_t$  = The absolute pressure (Static Pressure) in PSI(A) at time t  
 Temp $P_t$  = The flow temperature in degrees Rankine  
 Z = Compressibility factor

Notes:

1.  $PSI(A) = PSI(G) + 14.7$
2.  $^{\circ}R = (^{\circ}F + 459.67)$  or  $\{(1.8 \times ^{\circ}C) + 491.67\}$

**4.10.2 MATHS FUNCTION CONFIGURATION (Cont.)**

Fvalue

Outputs  $F_0$  in minutes. Solves the equation:

$$Fval_t = Fval_{t-1} + \left( 0.016666666 \times 10^{\frac{ma_t - \text{Target temp}}{Z}} \right)$$

where:  $Fval_t$  = F value at time 't'

$Fval_{t-1}$  = F value last iteration

$ma_t$  = Value of temperature measuring channel (Input Temp) at time 't'.

Target temp = Sterilization temperature = 249.98 °F (121.1°C)

Z = Z value = 50°F (10°C)

Note: Reset sets  $Fval_t$  to 0. If Z set to zero,  $Fval_t = 99999$

RH

Calculates % relative humidity from the following inputs.

Wet temp = wet bulb temperature in °C

Dry Temp = dry bulb temperature in °C

Atm Press = Atmospheric pressure in Bar.

Psy K = Psychrometric constant =  $6.66 \times 10^{-4}$

ZrO2 Sensor

Calculates partial pressure of oxygen, from a zirconia oxygen probe, using the equation:

$$P1 = \frac{P2}{10^{\frac{E}{0.0496 \times T}}}$$

where: P1 = partial pressure of oxygen (%) in the sampled gas

P2 = partial pressure of oxygen (%) in the reference atmosphere (20.95% for air)  
(Ref O2 %)

E = Probe electromotive force (emf) in mV

T = Probe temperature in Kelvins ( $K = °C + 273.18$ )

**4.10.3 Examples**

**HIGH AND LOW SELECT**

Figure 4.10.3a shows how two flow-rate transmitters, measuring the same flow, can be used to improve measurement resolution and accuracy at low flow levels.

Transmitter 1 is set up to measure flows between 0 and 100 gallons/minute

Transmitter 2 is set up to measure flows between 0 and 1000 gallons/minute

To trace the value on the chart, Channel 5 or 6 can be set up with Chart Range = 0 to 1000 gpm, Source DV = DV4

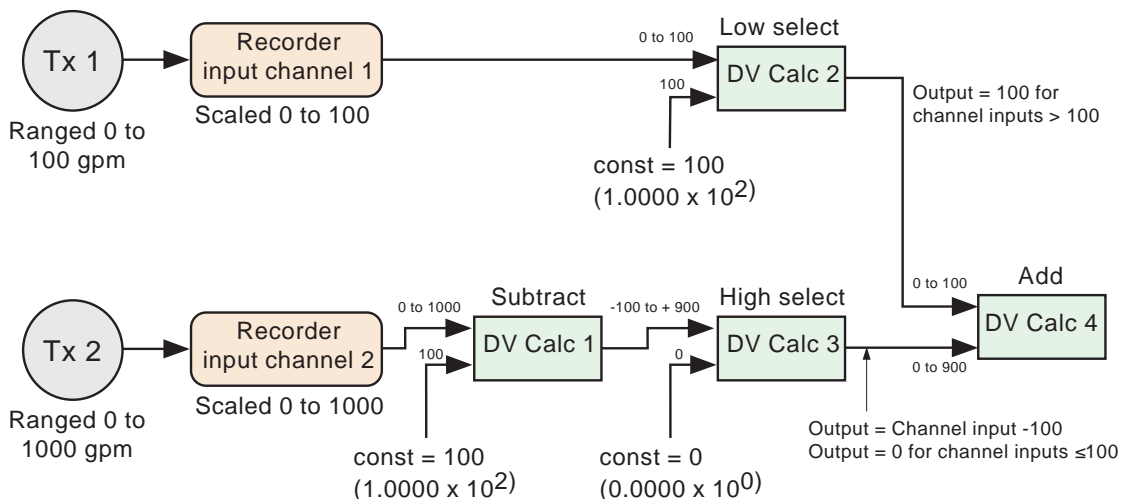

Figure 4.10.3 High/Low select application

4.10.3 EXAMPLES (Cont.)

MASS FLOW WITH PRESSURE AND TEMPERATURE COMPENSATION

Figure 4.10.3, below, shows a square root mass flow implementation, including the facility to use a fixed temperature input instead of the measured temperature. DV Calc 4 to DV Calc 8 are used in this switching process, which is initiated by the user setting the input 1 constant of DV Calc 6 to 1.0000 (to use measured temperature) or to 0.000 (to use the fixed temperature entered as a constant at DV calc 8).

DV Calc 6 is used only for convenience: the same effect can be achieved by setting the relevant constants of both DV Calc 4 and DV Calc 7 to 0 or 1, individually.

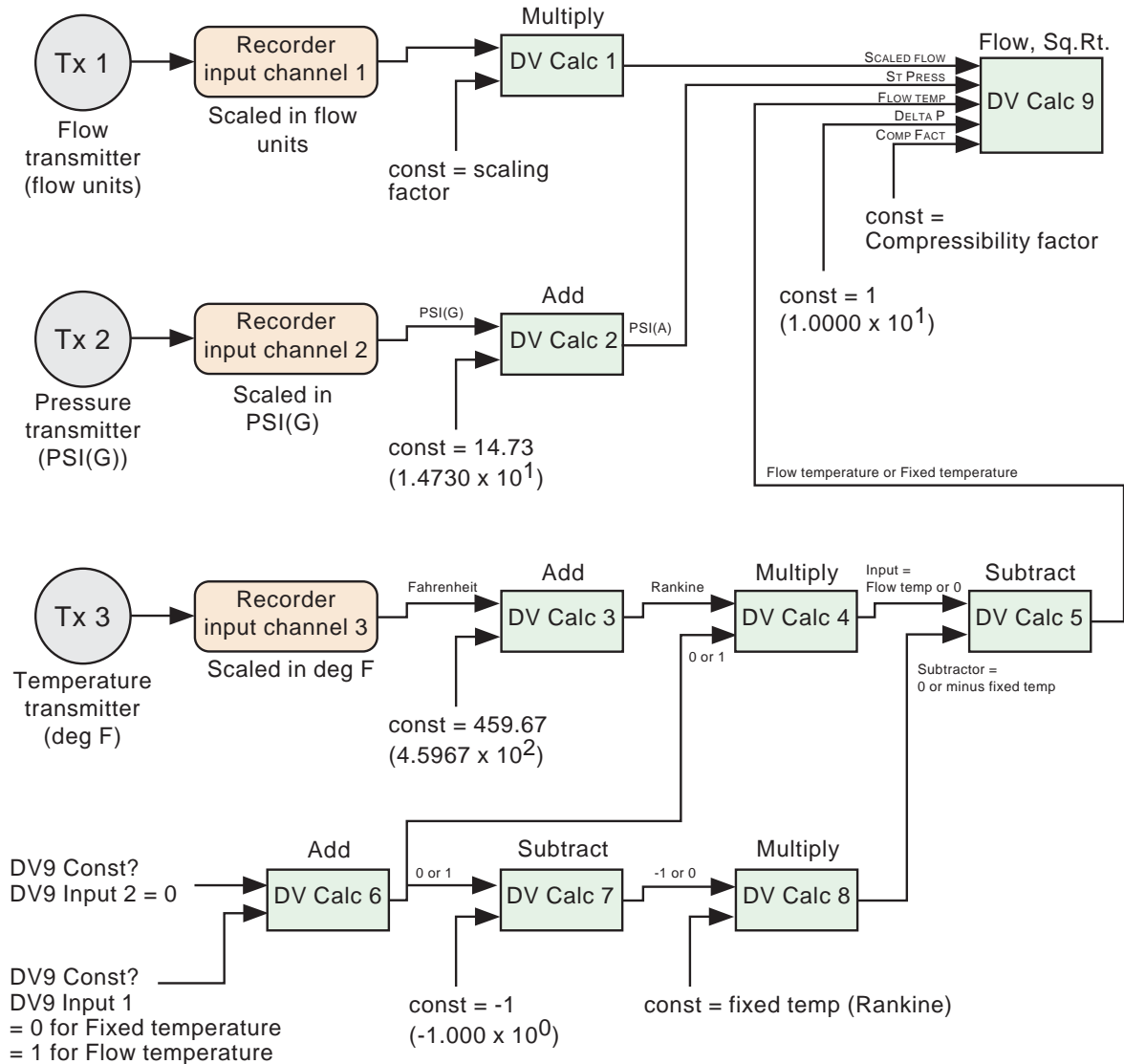

Figure 4.10.3b Square root mass flow with selectable temperature input

4.10.3 EXAMPLES (Cont.)

FINDING THE AVERAGE OF A NUMBER OF INPUTS

Figure 4.10.3c, produces the instantaneous average value of all four channel inputs by adding them all together and dividing by four.

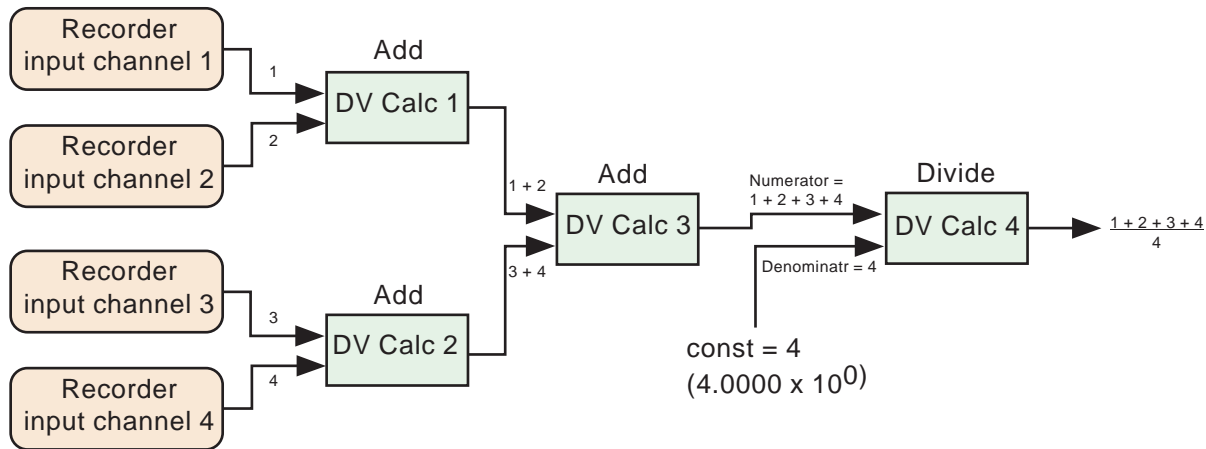

Figure 4.10.3c Multi-channel average

## 4.11 RETRANSMISSION OPTION

**Note:** This option shares an option board with event inputs, described in [section 4.12](#), below.

Up to two retransmission boards may be fitted, providing up to four retransmission outputs. These, scalable, outputs may be directly proportional to the linearised value of any of channels 1 to 4, to any of the DV Calc. values or to a setpoint generator trace 1 or 2 value. Retransmission outputs must be used when a Controller current (CAT) output is specified. Board number is automatically determined by the recorder (but see note 5)

When PID control loops are present, the following assignment represents the default setup. The assignments can be changed during configuration. Outputs not used for control loops can be used as normal.

Loop 1 output = Board 1, output A

Loop 2 output = Board 1, output B

Loop 1 duplex = Board 1 outputs A and B

Loop 2 duplex = Board 2 outputs A and B

### 4.11.1 Hardware configuration

Each circuit board has two links to define whether their associated retransmission output is to be Voltage or Current. The relevant positions for these links is shown in figure 4.11.1, below, which also shows the pinout.

Notes:

- 1 All three board definition links must be set to the same position
- 2 Voltage outputs can be set to either 0 to 5V or 1 to 5V in software configuration (section 4.11.2)
- 3 Current inputs can be set to 0 to 20 mA or 4 to 20 mA in software configuration (section 4.11.2)
- 4 For each board, the retransmission negative outputs are common.
5. On previous board versions, the board number was defined by three links on the board, all of which had to be set to board 1, or all set to board 2 position.

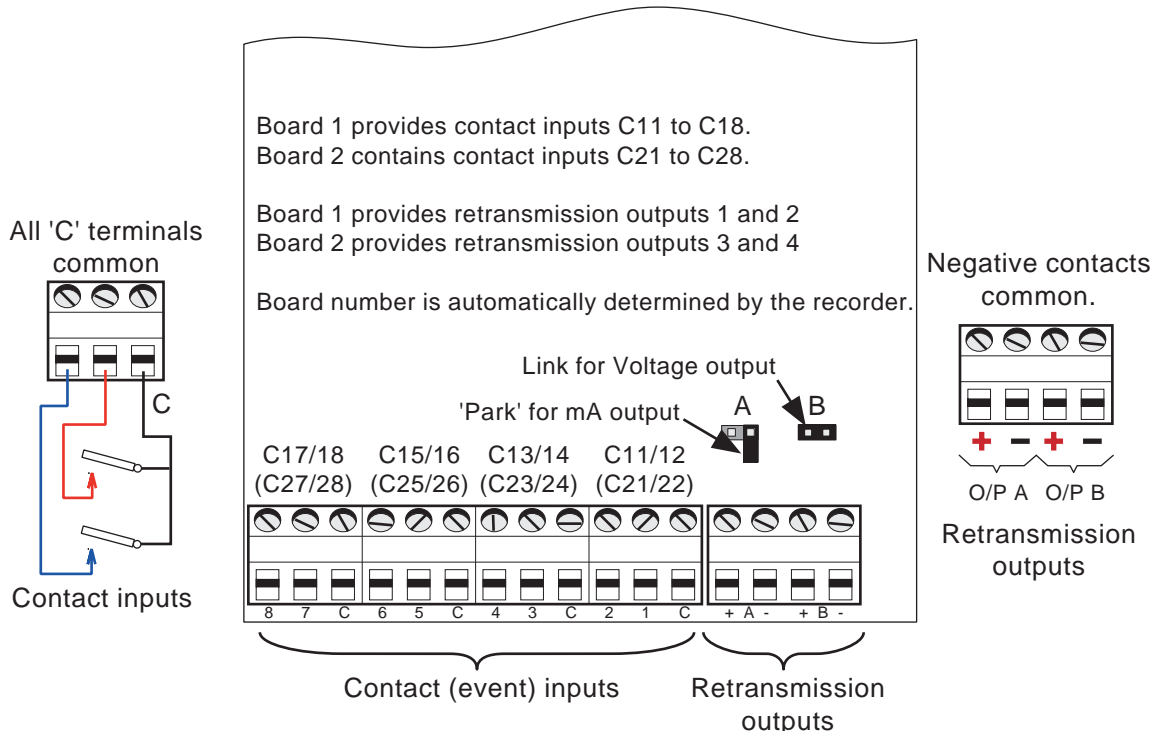

Figure 4.11.1 Retransmission/contact input: Hardware configuration and pinout

### 4.11.2 Software configuration

Figure 4.11.2 shows the retransmission menu structure.

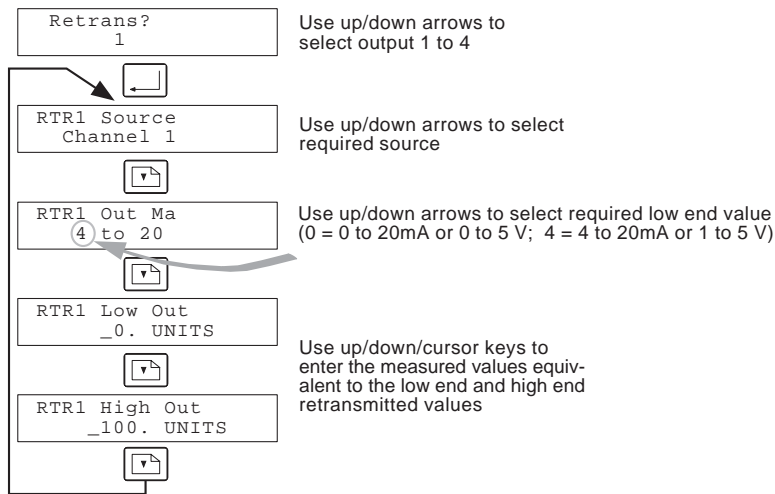

Figure 4.11.2 Retransmission configuration menu structure

#### CONFIGURABLE ITEMS

|          |  |
|----------|--|
| Source   | Select retransmission source from: Channels 1 to 4, DV1 to DV9, Controller 1 or 2, Setpoint Generator 1 or 2.                          |
| Out Ma   | Allows a low value to be selected for the output range.<br>0 selects 0 to 20 mA or 0 to 5 Volts; 4 selects 4 to 20 mA or 1 to 5 Volts. |
| Low Out  | Allows the user to enter the measured value equivalent to the 'zero' retransmission output.  |
| High Out | Allows the entry of the measured value equivalent to the full scale retransmission output.   |

Note: Displayed units are those of the source.

## 4.12 CONTACT (EVENT) INPUTS

This option is shared with the Retransmission Output option described in [section 4.11](#), above. The hardware configuration is the same as described in [section 4.11.1](#), except that the positions of the Volt/mA links are not relevant.

Each option board provides 8 inputs, which can be either contact closure or logic levels (low = active). The termination is arranged such that there is one common contact for every two contact inputs. This is for wiring convenience only, as all the 'C' contacts are commoned together on the circuit board. Figure 4.12, below shows typical wiring configurations.

Contact inputs are used only as sources for action equations. Board one inputs are denoted C11 to C18; board two inputs have the designation C21 to C28.

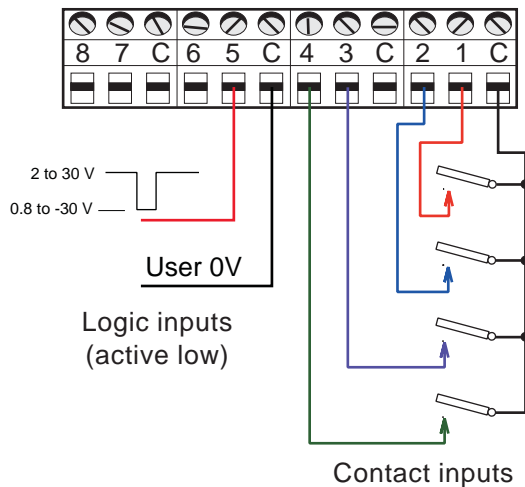

Figure 4.12 Contact input wiring

## 4.13 EVENT PEN

This option uses pen 3 or 4\* to act as an event marker. The pen normally traces at 100% chart, but moves in by 10% when a contact (e.g. switch or relay), wired to the input channel, is closed by the user. The input channel is fitted with a 250Ω shunt resistor.

\* Notes:

- 1 It is not possible to have four recording channels and an event marker,
- 2 Pen 4 is used if there are three recording channels fitted.; pen 3 is used if there are only two recording channels fitted.

## 5 CALIBRATION

Note: Amongst other things, the calibration function offers the means of calibrating input channels and cold junction compensation using precision signal standards. Calibration should not be used to set up a recorder to measure a particular input - this should be done using the configuration menus described in [section 4](#), above.

Figure 5 shows the top level calibration menu. Lower levels are described in later sub-sections.

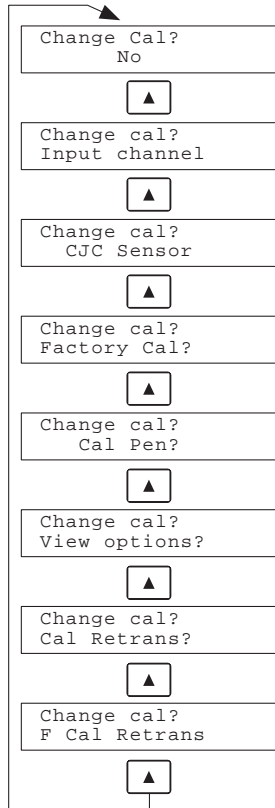

Figure 5 calibration manu

## 5.1 INPUT CHANNEL CALIBRATION

Input channel calibration allows all the ranges of all the input channels to be calibrated against precision input signals. Figure 5.1 shows the menu structure.

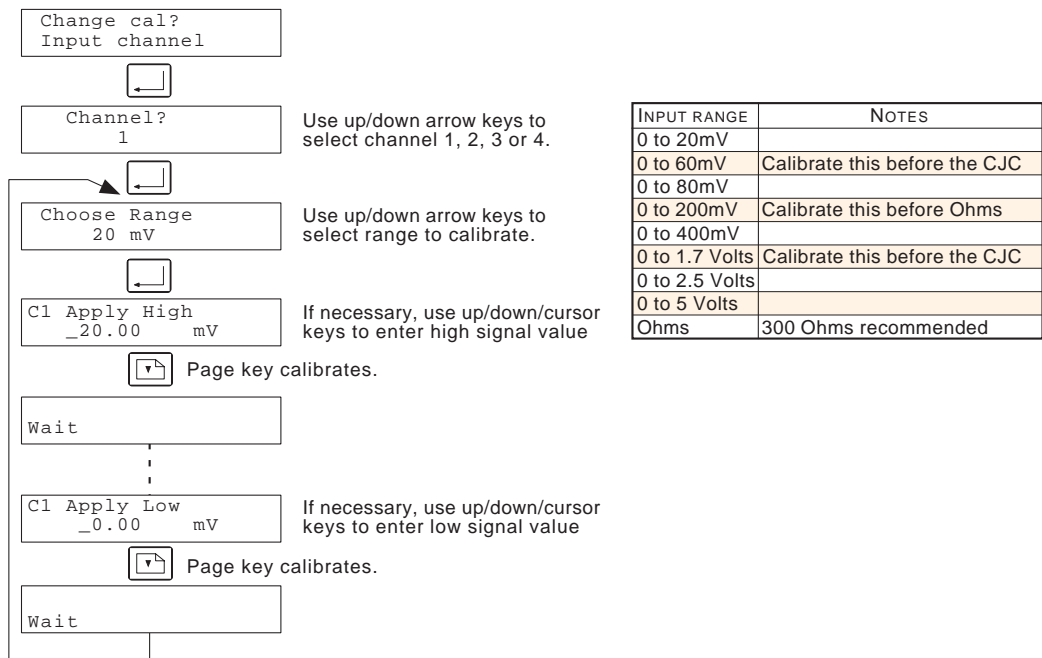

Figure 5.1 Input channel calibration

### 5.1.1 Input channel calibration procedure

For each channel, there are nine ranges to calibrate, as shown in the table above. The procedure is the same for each, as follows:

1. Select a channel for calibration, as described in figure 5.1 above. Press Enter.
2. Select a range, using the up/down arrow keys, then press Enter.

**Note:** It is recommended that all ranges be calibrated, in the order that they appear in the picklist. In particular, the 60 mV and 1.7 V ranges should be calibrated before CJC calibration, and the 200 mV range before Ohms calibration.

3. Apply the requested calibrating signal high value\* (e.g. 20mV) across the channel terminals, then press the page key.
4. After the 'Wait' message has disappeared, apply the requested calibrating signal low value\* (e.g. 0 mV) across the channel terminals, then press the page key.
5. After the 'Wait' message has disappeared, select a new range and repeat the procedure.
6. Repeat for all required channels.

**\*Note:** If it is not possible to apply exactly the requested value of calibration signal, then use the up/down/cursor keys to enter the value of a signal that is available. This should be as close to the requested value as possible.

## 5.2 CJC SENSOR CALIBRATION

This procedure calibrates the cold junction compensation which is applied to the recorder input signals when thermocouple inputs are configured for use. The procedure should be applied to both input boards if more than one is fitted.

The procedure requires a Type J thermocouple, maintained at a known temperature, (or a Type J thermocouple simulator) to be connected across input 1 of the board whose CJC sensor is to be calibrated (i.e. channel 1 or channel 3).

Figure 5.2 shows the CJC calibration menu.

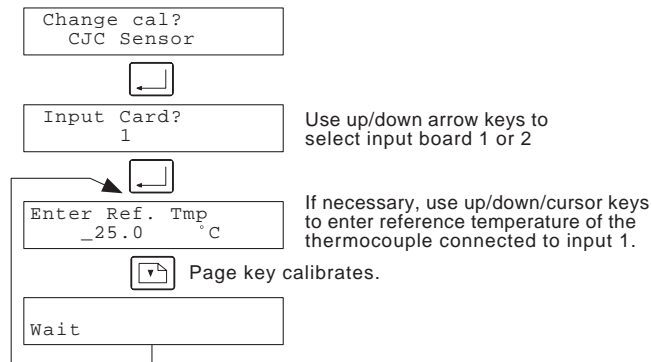

Figure 5.2 CJC Calibration menu

### 5.2.1 CJC sensor calibration procedure

1. Select board 1 or 2 (if fitted). Press 'Enter'
2. Connect a type J thermocouple, maintained at a known temperature, or a Type J simulator to input 1 of the subject board.
3. If necessary, use the up/down/cursor keys to enter the thermocouple temperature. Press the Page key.
4. After the 'Wait' message has gone, repeat for the other board.

## 5.3 RESTORE FACTORY CALIBRATION

This allows all user calibrations to be discarded on a channel-by-channel basis.

### 5.3.1 Restore factory calibration procedure

1. Use the up/down arrow keys to select the required channel, then press 'Enter'
2. Press Enter again, in response to the 'ENTER to confirm' message which appears. (Press the 'Clear' key to quit.)
3. After the 'Wait' message has gone, select a further channel if required.

### 5.4 PEN CALIBRATION

This allows the user to set the pens to align with the chart zero and full scale markings. It is recommended that a new chart be used to ensure good trace visibility. Figure 5.4 shows the calibration menu.

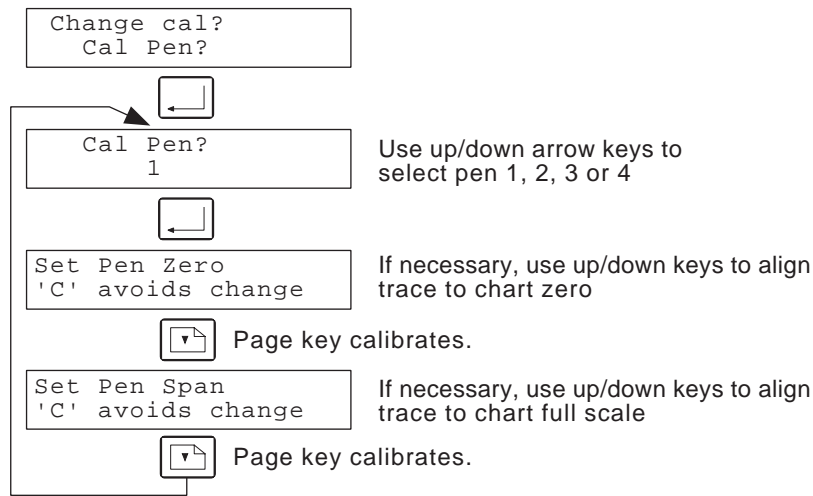

Figure 5.4 Pen calibration menu

#### 5.4.1 Pen calibration procedure

1. Use the up/down arrow keys to select the required pen, and press 'Enter'.
2. The selected pen moves towards the centre of the chart, and stops where it believes chart zero to be. If necessary, use the up/down keys to adjust the pen tip position to chart zero. When the pen tip and chart zero are aligned, press the Enter key.
3. Press the Page key. The pen moves towards the outside edge of the chart, and stops where it believes chart full scale to be. If necessary, use the up/down keys to adjust the pen tip position to chart full scale. When the pen tip and chart full scale are aligned, press the Enter key.
4. Press the Page key, and select another pen for calibration. (The pen just calibrated moves to its normal tracing position.)

### 5.5 VIEW OPTIONS

This displays a 16 character number which can be decoded to determine which options are fitted to the recorder.

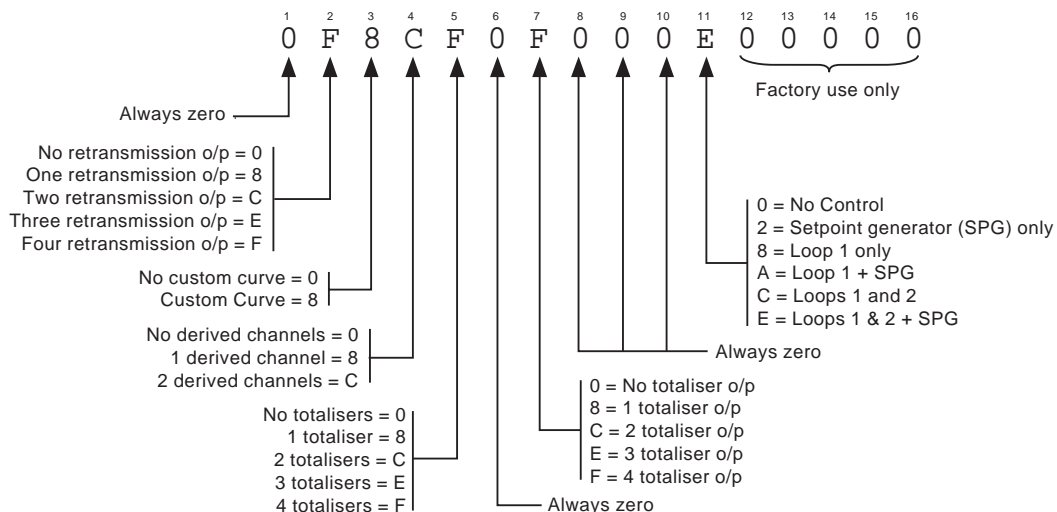

Figure 5.5 Option fit decoding

## 5.6 RETRANSMISSION OUTPUT CALIBRATION

This allows the user to calibrate the retransmission output channels.

### 5.6.1 Retransmission calibration procedure

1. Use the up/down arrow keys to select the output for calibration, but do not press enter yet.
2. Connect the output to be calibrated to channel 1 input (+ to +, - to -), using a 250 $\Omega$  shunt if the output is set up as a current output (ref. [section 4.11](#))
3. Press Enter to calibrate. After 'Wait' message, select another output, if required, and repeat.

## 5.7 RETURN RETRANSMISSION OUTPUT TO FACTORY CALIBRATION

This allows all user retransmission calibrations to be discarded on a channel-by-channel basis. Input channel calibration is not affected.

### 5.7.1 Restore factory calibration procedure

1. Use the up/down arrow keys to select the required channel, then press 'Enter'
2. Press Enter again, in response to the 'ENTER to confirm' message which appears. (Press the 'Clear' key to quit.)
3. After the 'Wait' message has gone, select a further channel if required.

## 6 UPGRADE AND FAULT LOCATION

### 6.1 PROMS AND RAM

Figure 6.1 is a representation of the main board, showing the locations of the various memory chips.

The recorder operating programs are held in a plug-in EPROM (U17) located near the centre of the main board.

A 2kB serial EEPROM (U3), near the top left corner of the main board, is used to store the following configurations: input channels, input channel alarms, password, chart speed, chart hold status, relays, custom curve, totaliser, derived channels, derived channel alarms, derived variables, retransmission outputs, timers, controller and communications. A further similar EEPROM (U4) is used to hold configuration data for the setpoint generator option.

All this data is also held in RAM, and is retained there for 100 hours without power by the 0.47F 'Super cap' on the main board. The RAM area is also used to store items which have a history component i.e.

1. Totaliser values,
2. Derived variable values for Average, Hi/Lo peak and Fvalue
3. Controller values for Output, A/M choice, integral term, derivative term
4. Setpoint generator values for Elapsed and segment times, Current segment, Mode choice.

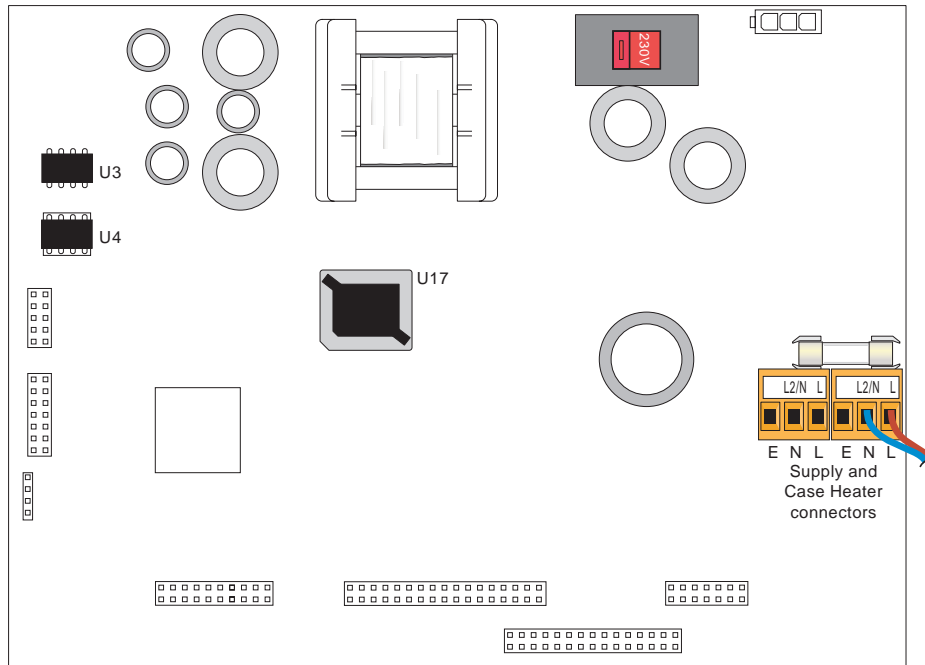

Figure 6.1 EEPROM locations

### 6.2 RECORDER UPGRADE

Field addition or removal of options, and software update to operate with certain added hardware options is carried out using a 'Feature Addition Kit', containing a 2k serial EEPROM, and, if necessary, a replacement main EEPROM.

To add new options, isolate the recorder from supply power, then insert the 8-pin EEPROM into socket U4. If necessary, prise the existing main EEPROM out of its socket and replace it with the new one supplied with the kit. Re-apply power to the recorder.

**Note:** It is recommended that the EEPROM be left in socket U4. Once used in one recorder, it cannot be used to upgrade another.

### 6.3 FAULT LOCATION

The fault location guide is intended to allow the user to locate an operational fault to a specific circuit board.

---

**CAUTION**

When trouble-shooting by board change, the user must take adequate protective measures against damage being caused by electrostatic discharge.

---

---

Notes:

1. The recorder's software features are resident on the main board. If the main board is replaced, the features on the new board may not be the same as those on the replaced board.
  2. It is assumed in figure 6.3 that, if the recorder fails to power up, the supply voltage wiring and fuse status have been checked.
-

6.3 FAULT LOCATION (Cont.)

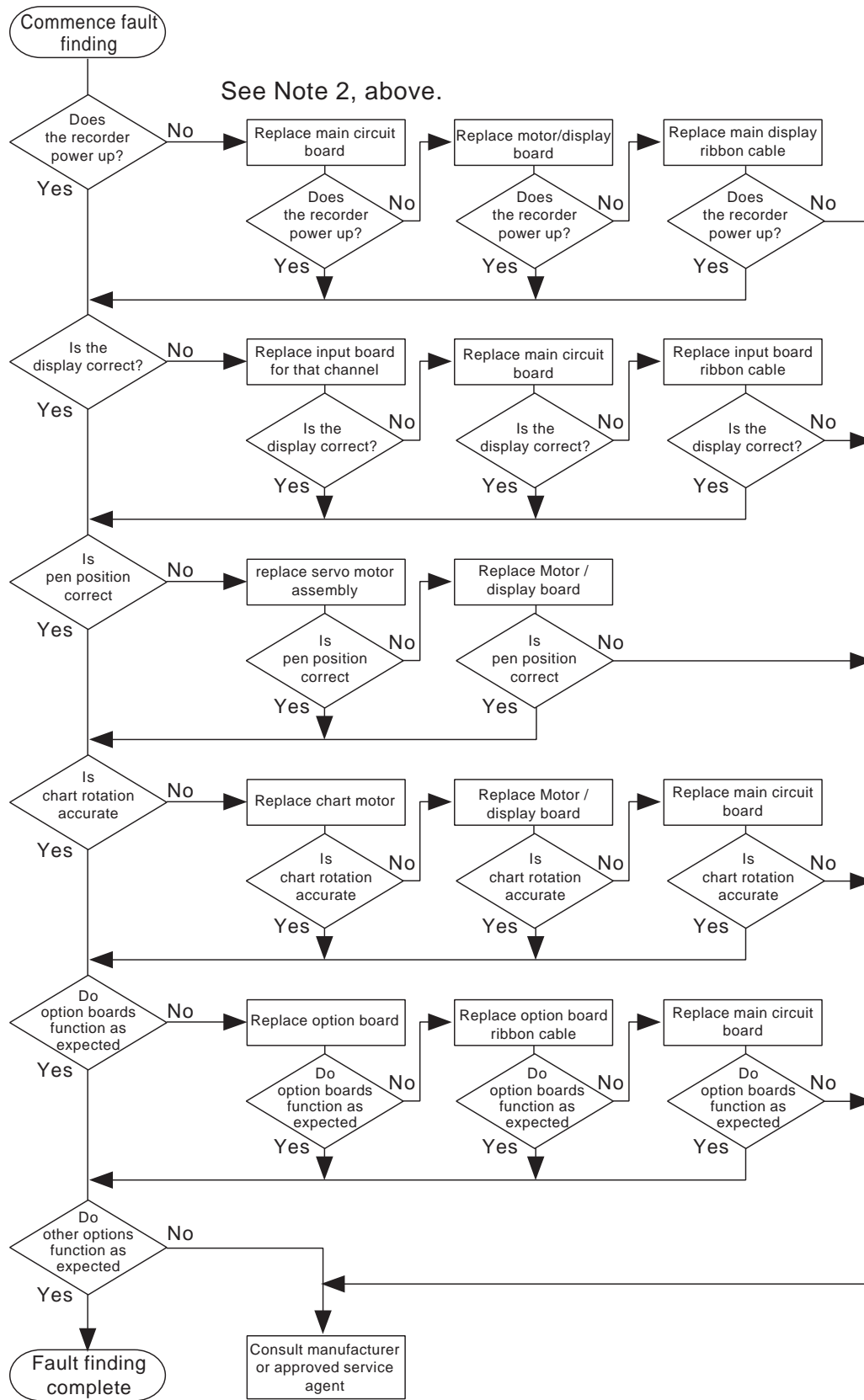

Figure 6.3 Fault finding guide

## ANNEX A SPECIFICATION

### Inputs

|                     |                            |  |
|---------------------|----------------------------|--|
| Number of inputs    |                            | 1, 2, 3 or 4   |
| Input types         | Thermocouples:             | Types B, C, E, J, K, L, N, R, S, T, Ni-NiMo  |
|                     | Resistance thermometers:   | 100Pt, 10Cu, 100Ni, 120Ni.   |
|                     | Voltage:                   | 4mV to 5V dc   |
|                     | Current:                   | 250Ω shunt   |
|                     | Contact closure option:    | One or two sets of eight. Contact closure or logic low = active  |
| Zero offset         |                            | -20% to +100% of the gain step selected by the recorder - see table A1 for range steps.                      |
| Linearisation types |                            | Thermocouple, RTD, Square root, 3/2 power, 5/2 power, log <sub>10</sub> , Custom curve                       |
| Linearisation error |                            | ± 0.3°C  |
| Scan rate           |                            | Each channel scanned every 500 msec.   |
| CJC rejection ratio |                            | 25:1   |
| CJC accuracy        |                            | ± 0.5 °C at 25 °C reference  |
| Input ranges        |                            | Selected automatically by the recorder using the configured high input value as the criterion. See table A1. |
| Input resolution    |                            | See table A1.  |
| Input impedance     |                            | >20 MΩ   |
| Rejection           | Common mode:               | 120 dB at 50/60 Hz   |
|                     | Series mode:               | 60 dB at 50/60 Hz  |
| Isolation           | Isolated input boards:     | Each input to 250 Vac  |
|                     | Non-isolated input boards: | Two channels with common negative connection: to 250V ac from ground.  |

| Gain step | Input range       | Resolution |
|-----------|-------------------|------------|
| 20 mV     | - 4 to + 20 mV    | 2 μV       |
| 60 mV     | - 12 to + 60 mV   | 6 μV       |
| 80 mV     | - 16 to + 80 mV   | 8 μV       |
| 200 mV    | - 40 to + 200 mV  | 20 μV      |
| 400 mV    | - 80 to + 400 mV  | 40 μV      |
| 1.7 V     | - 0.34 to + 1.7 V | 170 μV     |
| 2.5 V     | - 0.5 to + 2.5 V  | 250 μV     |
| 5 V       | - 1 to + 5.0 V    | 500 μV     |

Table A1: Gain steps, ranges and resolutions

### Writing system

|                           |  |
|---------------------------|--|
| Pen colours               | Blue (channel 1), Red, Green and black (channel 4)                 |
| Pen type                  | Fibre-tipped disposable (FTD) - line length >450 metres (1500 ft.) |
| Pen positional accuracy   | 1.0% of chart range  |
| Pen positional resolution | 0.2% of chart range  |
| Pen response              | 5 seconds, 0 to full scale.  |
| Chart type                | Circular, 100 mm calibrated chart width                            |
| Chart rotation speeds     | Configurable between 1 and 4096 hours per rev.                     |
| Standard chart periods    | 24 hour, 7 day.  |

### Non-volatile memory

|                |                                       |
|----------------|---------------------------------------|
| Configuration: | Saved in EEPROM                       |
| Active values: | Retained for 100 hours by 'supercap'. |

See [section 6.1](#) for more details

### Display

|                |                                      |
|----------------|--------------------------------------|
| Basic accuracy | 0.05% of gain step + 0.5% of reading |
|----------------|--------------------------------------|

### Environmental

|                             |   |
|-----------------------------|---|
| Operating temperature range | 0 to + 50°C (-20 °C to + 50 °C with case heater option) |
| Humidity                    | 10 to 90% RH, non-condensing                            |
| Exposure                    | Protect from direct sunlight.                           |

Note: The bezel vertical centre line is offset from panel cutout vertical centre line - see figure 2.1.1

### Physical

|                    |   |
|--------------------|---|
| Bezel              | 380 mm (W) x 360 mm (H)                         |
| Panel cutout       | 345 mm (W) x 340 mm (H)                         |
| Depth behind bezel | 148 mm  |
| Weight             | 7 kg (approximate - depends on options fitted). |

**ANNEX A: SPECIFICATION (Cont.)**

**Power requirements**

|                |                                  |  |
|----------------|----------------------------------|--|
| Supply voltage | Standard:                        | Operator selectable switch 120 V or 240 V (both -25% + 10%; 45 to 65 Hz)       |
|                | Optional:                        | 24V dc   |
| Power          | AC supply:                       | <25 VA (115 VA with case heater option).                                       |
|                | 24 V dc supply                   | <25 W  |
| Fuses          | Main board:                      | 240 V supply = 500 mA; 120 V supply = 1 A; 24V supply = 2 A (all 'slow blow' ) |
|                | Supply power line:               | ≤ 3 A  |
|                | Transmitter power supply option: | 240 V supply = 63 mA; 120 V supply = 100 mA (both 'slow blow')                 |

**Electrical safety**

BS EN61010. Installation category II; Pollution degree 2 (See panel below)

**Relay outputs**

**WARNING!**

Prior to mid 1996, output relay contacts were rated at 125V (resistive). Applying 250V across the terminals of such relays may endanger personnel. Since mid 1996, output relay contacts have been rated at 250V (resistive).

Relay type may be determined by visual inspection: the 125V relay is enclosed in a metal case; the 250V relay is enclosed in a plastic case. In case of doubt, please contact the supplier of the recorder.

|                            |  |
|----------------------------|--|
| Maximum number of relays   | Up to two sets of four, individually assignable.                         |
| Contact rating             |  |
| Maximum switching power:   | 150 W or 250 VA (resistive)  |
| Maximum switching voltage: | 250 V (resistive)  |
| Maximum switching current: | 1.0 A (resistive) providing the maximum switching power is not exceeded. |

**Communications option**

|          |         |
|----------|---------|
| Standard | EIA 422 |
|----------|---------|

**Retransmission option**

|                   |   |
|-------------------|---|
| Number of outputs | Up to 2 boards, each with two outputs.  |
| Output type       | Scaled 0 to 20 mA or 4 to 20 mA (600 Ω max) or 0 to 5 V or 1 to 5 Volts. Isolated from recorder supply, but with common negative outputs per board. |
| Output accuracy   | Displayed measured value ± 0.1% retransmitted span  |

**Transmitter power supply**

|         |   |
|---------|---|
| Output: | Four isolated, 28 V dc supplies, sourcing up to 24 mA each. |
|---------|---|

**INSTALLATION CATEGORY AND POLLUTION DEGREE**

This product has been designed to conform to BS EN61010 installation category II and pollution degree 2. These are defined as follows:

**INSTALLATION CATEGORY II**  
The rated impulse voltage for equipment on nominal 230V ac mains is 2500V.

**POLLUTION DEGREE 2**  
Normally, only non-conductive pollution occurs. Occasionally, however, a temporary conductivity caused by condensation shall be expected.

## INDEX

|                                      |        |                                     |        |
|--------------------------------------|--------|-------------------------------------|--------|
| <b>A</b>                             |        | <b>Configuration (Cont.)</b>        |        |
| Absolute alarms .....                | 32     | Display characteristics .....       | 21     |
| Access to Configuration switch ..... | 23     | Input channel .....                 | 24     |
| Act Eq (Relay) .....                 | 34     | Instrument .....                    | 28     |
| Action equations .....               | 29     | Relay outputs .....                 | 34     |
| Add .....                            | 40     | Retransmission .....                | 45     |
| Alarm                                |        | Timers .....                        | 38     |
| Access .....                         | 29     | Totaliser .....                     | 35     |
| Configuration .....                  | 32     | Contact input option .....          | 47     |
| Instrument .....                     | 17     | Continuous totaliser .....          | 37     |
| Operator menu .....                  | 19     | Custom curve                        |        |
| Symbols .....                        | 17     | Enable/disable .....                | 29     |
| Types .....                          | 32     | Entry .....                         | 30     |
| Alarm? .....                         | 19     | <b>D</b>                            |        |
| Aligning pens to the chart .....     | 51     | Dat Output .....                    | 34     |
| Alt Chart Spd .....                  | 19, 28 | Deadband .....                      | 33     |
| Average .....                        | 41     | Deadband alarms .....               | 32     |
| <b>B</b>                             |        | Dec. Point .....                    | 25, 27 |
| Bd1/Bd2 links                        |        | Derived channel                     |        |
| Input board .....                    | 13     | Configuration .....                 | 27     |
| Retransmission board .....           | 45     | Derived variables (DV) option ..... | 39     |
| Bell symbol .....                    | 17     | Display .....                       | 21     |
| <b>C</b>                             |        | Divide .....                        | 40     |
| Calibration .....                    | 48     | Duration (timer) .....              | 38     |
| Case heater                          |        | DWN/UP link .....                   | 13     |
| Wiring .....                         | 9      | <b>E</b>                            |        |
| Ch Adjust .....                      | 25     | Event input .....                   | 47     |
| Ch Desc .....                        | 25, 27 | Event Pen option .....              | 47     |
| Changing                             |        | Ext CJC Temp .....                  | 29     |
| Pens .....                           | 15     | <b>F</b>                            |        |
| The chart .....                      | 14     | Factor .....                        | 37     |
| Channel                              |        | Entry .....                         | 35     |
| Configuration .....                  | 24     | Fault location guide .....          | 54     |
| Hold .....                           | 16     | Filter time .....                   | 25     |
| Character set .....                  | 22     | Fitting                             |        |
| Chart                                |        | The chart .....                     | 14     |
| Hold .....                           | 19     | The pens .....                      | 15     |
| Low/High .....                       | 25, 27 | Flow                                |        |
| Ch Hold Eq .....                     | 28     | Linear .....                        | 41     |
| Circuit board location .....         | 12     | Square root .....                   | 41     |
| CJ point pair .....                  | 31     | Fvalue .....                        | 42     |
| CJ1/CJ2/CJ3                          |        | <b>G</b>                            |        |
| mV .....                             | 31     | Global alarm symbol .....           | 17     |
| Temp .....                           | 31     | <b>H</b>                            |        |
| CJC                                  |        | High Out .....                      | 46     |
| Sensor calibration .....             | 50     | High peak .....                     | 40     |
| Type .....                           | 25     | High select .....                   | 40     |
| CJC/RTD link .....                   | 13     | Hold Eq .....                       | 37     |
| Cntr Out .....                       | 37     | Hysteresis .....                    | 33     |
| Configuration                        |        |                                     |        |
| Access .....                         | 29     |                                     |        |
| Switch .....                         | 23     |                                     |        |
| Alarm .....                          | 32     |                                     |        |
| Contact (Event) inputs .....         | 47     |                                     |        |
| Derived channels .....               | 27     |                                     |        |
| Derived variables .....              | 39     |                                     |        |

|                                       |        |                                |        |
|---------------------------------------|--------|--------------------------------|--------|
| <b>I</b>                              |        | <b>R</b>                       |        |
| Input board links .....               | 13     | Range Low/High .....           | 25     |
| Input channel                         |        | Rate Base .....                | 33     |
| Calibration .....                     | 49     | Rate-of-change alarms .....    | 33     |
| Configuration .....                   | 24     | Relay outputs .....            | 34     |
| Input Low/High .....                  | 25     | Relay type .....               | 34     |
| Input Type .....                      | 25     | Reset DV Val? .....            | 19     |
| Installation                          |        | Resettable (totaliser) .....   | 37     |
| Chart .....                           | 14     | Retransmission option .....    | 45     |
| Electrical .....                      | 9      | Calibration .....              | 52     |
| Mechanical .....                      | 8      | RH .....                       | 42     |
| Pen .....                             | 15     | Rset Eq                        |        |
| Instrument alarm symbol .....         | 17     | Totaliser .....                | 37     |
| Instrument configuration .....        | 28     | Rset eq                        |        |
| Inverse I symbol .....                | 17     | Timer .....                    | 38     |
| <b>K</b>                              |        | Rset Total? .....              | 19     |
| Keyboard .....                        | 21     | <b>S</b>                       |        |
| <b>L</b>                              |        | Safety notes .....             | 5      |
| Labelling symbols .....               | 5      | Scaling (totaliser) .....      | 35     |
| Lin Funct. ....                       | 25     | Selecting board 1 or board 2   |        |
| Lin. Slope .....                      | 40     | Input board .....              | 13     |
| Log base 10 .....                     | 41     | Selecting board 1/board 2      |        |
| Low Out .....                         | 46     | Retransmission .....           | 45     |
| Low Peak .....                        | 40     | Setpoint .....                 | 33     |
| Low select .....                      | 40     | Setting                        |        |
| Low/Hi cutoff .....                   | 37     | Chart speeds .....             | 28     |
| <b>M</b>                              |        | Supply voltage switch .....    | 10     |
| Maths functions available .....       | 39     | Signal DP Pos .....            | 31     |
| Memory location .....                 | 53     | Signal wiring .....            | 10     |
| Multiply .....                        | 40     | Soft key .....                 | 18     |
| <b>O</b>                              |        | Enable/disable .....           | 28     |
| Operating displays .....              | 16     | Source .....                   | 37, 46 |
| Operator interface .....              | 21     | Source DV .....                | 27     |
| Operator menu .....                   | 18     | Spd Act Eq .....               | 28     |
| Option board types .....              | 12     | Specification                  |        |
| Options display .....                 | 51     | Communications .....           | 57     |
| Out Fact .....                        | 37     | Display .....                  | 56     |
| Out Ma .....                          | 46     | Electrical safety .....        | 57     |
| <b>P</b>                              |        | Inputs .....                   | 56     |
| Password                              |        | Non-volatile memory .....      | 56     |
| Editing .....                         | 29     | Physical characteristics ..... | 56     |
| Pen                                   |        | Power requirements .....       | 57     |
| Calibration .....                     | 51     | Relay outputs .....            | 57     |
| Parking .....                         | 19     | Retransmission .....           | 57     |
| Select .....                          | 27     | transmitter power supply ..... | 57     |
| Periodic timers .....                 | 38     | Writing system .....           | 56     |
| Pinouts (input & option boards) ..... | 10     | Subtract .....                 | 40     |
| Point pair .....                      | 31     | Supply voltage                 |        |
| Polynomial .....                      | 41     | Selection .....                | 10     |
| Power of 10 .....                     | 41     | Wiring .....                   | 9      |
| Preload .....                         | 37     | Symbols used on labels .....   | 5      |
| Preset .....                          | 37     | <b>T</b>                       |        |
| Preset up/down .....                  | 37     | TC/RTD link .....              | 13     |
| Pri Chart Spd .....                   | 28     | Text entry .....               | 22     |
| Prog Units .....                      | 25, 27 | Timer option .....             | 38     |
|                                       |        | Tot X .....                    | 34     |
|                                       |        | Totaliser option .....         | 35     |
|                                       |        | Transmitter power supply ..... | 11     |

**U**

|                                |        |
|--------------------------------|--------|
| Unit DP Pos .....              | 31     |
| Units .....                    | 25, 37 |
| Unpacking and inspection ..... | 7      |
| Upgrade .....                  | 53     |

**V**

|                             |    |
|-----------------------------|----|
| View                        |    |
| DV val? .....               | 19 |
| Timer? .....                | 19 |
| Total? .....                | 19 |
| Volatile data storage ..... | 53 |
| Voltage/Current links ..... | 45 |

**W**

|                                |    |
|--------------------------------|----|
| Warranty statement .....       | 6  |
| Which options fitted? .....    | 51 |
| Wiring                         |    |
| Case heater .....              | 9  |
| Installation .....             | 12 |
| Signal .....                   | 10 |
| Supply voltage .....           | 9  |
| Transmitter power supply ..... | 11 |

**Z**

|                   |    |
|-------------------|----|
| ZRO2 sensor ..... | 42 |
|-------------------|----|

# Inter-Company sales and service locations

## Australia

Eurotherm Pty. Limited.  
Unit 10.  
40 Brookhollow Avenue,  
Baulkham Hills,  
NSW 2153

Telephone: 61 2 9634 8444  
Fax: 61 2 9634 8555  
e-mail: [eurotherm@eurotherm.com.au](mailto:eurotherm@eurotherm.com.au)  
<http://www.eurotherm.com.au>

## Austria

Eurotherm GmbH  
Geiereckstraße 18/1,  
A1110 Wien,

Telephone: 43 1 798 76 01  
Fax: 43 1 798 76 05  
e-mail: [eurotherm@eurotherm.at](mailto:eurotherm@eurotherm.at)  
<http://www.eurotherm.at>

## Belgium and Luxembourg

Eurotherm S.A./N.V.  
Rue du Val-Notre-Dame 384,  
4520 Moha (Huy)  
Belgium

Telephone: 32 (0) 85 274080  
Fax: 32 (0) 85 274081  
e-mail: [sales@eurotherm-belgium.be](mailto:sales@eurotherm-belgium.be)  
<http://www.eurotherm.nl>

## Denmark

Eurotherm Danmark A/S  
Finsensvej 86,  
DK 2000 Fredriksberg,

Telephone: +45 (38) 871622  
Fax: +45 (38) 872124  
e-mail: [salesdk@eurotherm.se](mailto:salesdk@eurotherm.se)

## Finland

Eurotherm Finland,  
Aurakatu 12A,  
FIN-20100 Turku

Telephone: 358 2 25 06 030  
Fax: 358 2 25 03 201

## France

Eurotherm Automation Division Chessell  
Parc d'Affaires,  
6, Chemin des Joncs,  
BP55

F - 69574 Dardilly, CEDEX  
Telephone: 33 0 4 78 66 55 20  
Fax: 33 0 4 78 66 55 35  
e-mail: [chessell@automation.eurotherm.co.uk](mailto:chessell@automation.eurotherm.co.uk)  
<http://www.eurotherm-chessell.fr>

## Germany

Eurotherm Deutschland GmbH  
Ottostraße 1,  
65549 Limburg

Tel: +49 (0) 64 31/2 98 - 0  
Fax: +49 (0) 64 31/2 98 - 1 19  
e-mail: [info@regler.eurotherm.co.uk](mailto:info@regler.eurotherm.co.uk)  
<http://www.eurotherm-deutschland.de>

## Great Britain

Eurotherm Limited,  
Faraday Close,  
Worthing,  
West Sussex BN13 3PL

Telephone: +44 (0)1903 695888  
Fax: +44 (0)1903 695666  
e-mail: [Sales@recorders.eurotherm.co.uk](mailto:Sales@recorders.eurotherm.co.uk)  
or: [Support@recorders.eurotherm.co.uk](mailto:Support@recorders.eurotherm.co.uk)  
<http://www.eurotherm.co.uk>

## Hong Kong

Eurotherm Limited,  
Unit D, 18/F Gee Chang Hong Centre,  
65, Wong Chuk Hang Road,  
Aberdeen.

Telephone: 852 2873 3826  
Fax: 852 2870 0148  
e-mail: [eurotherm@eurotherm.com.hk](mailto:eurotherm@eurotherm.com.hk)

## India

Eurotherm DEL India Limited,  
152, Developed Plots Estate,  
Perungudi,  
Chennai 600 096,

Telephone: 91 44 4961129  
Fax: 91 44 4961831  
e-mail: [info@eurothermdel.com](mailto:info@eurothermdel.com)  
<http://www.eurothermdel.com>

## Italy

Eurotherm SpA,  
Via XXIV Maggio,  
I-22070 Guanzate,  
Como.

Telephone: 39 031 975111  
Fax: 39 031 977512  
e-mail: [info@eurotherm.it](mailto:info@eurotherm.it)  
<http://www.eurotherm.it>

## Japan

Densei Lambda K.K.,  
Strategic Products Dept.  
5F Nissay Aroma Square,  
37-1, Kamata, 5-Chome,  
Ohta-ku,  
Tokyo 144-8721

Telephone: 81 3 5714 0620  
Fax: 81 3 5714 0621  
e-mail (Sales): [k.iwama@densai-lambda.com](mailto:k.iwama@densai-lambda.com)  
e-mail (Technical): [v.rendle@densai-lambda.com](mailto:v.rendle@densai-lambda.com)  
<http://www.densei-lambda.com>

## Korea

Eurotherm Korea Limited,  
J- Building  
402-3  
Poongnab-Dong,  
Songpa-Ku  
Seoul, 138-040

Telephone: 82 2 478 8507  
Fax: 82 2 488 8508

## Netherlands

Eurotherm BV,  
Genielaan 4,  
2404CH Alphen aan den Rijn,  
The Netherlands

Telephone: 31 172 411 752  
Fax: 31 172 417 260  
e-mail: [Sales@eurotherm.nl](mailto:Sales@eurotherm.nl)  
<http://www.eurotherm.nl>

## Norway

Eurotherm A/S,  
Vollsveien 13D  
1366 Lysaker,  
Postboks 227  
NO-1326 Lysaker  
Norway,

Telephone: 47 67 592170  
Fax: 47 67 118301  
<http://www.eurotherm.no>

## Spain

Eurotherm España SA,  
Pol. Ind. De Alcobendas,  
Calle de la Granja 74,  
28108 Alcobendas,  
Madrid.

Telephone: 34 91 661 60 01  
Fax: 34 91 661 90 93  
<http://www.eurotherm.es>

## Sweden

Eurotherm AB,  
Lundavägen 143,  
S-21224 Malmö.

Telephone: 46 40 38 45 00  
Fax: 46 40 38 45 45  
e-mail: [info@eurotherm.se](mailto:info@eurotherm.se)  
<http://www.eurotherm.se>

## Switzerland

Eurotherm Produkte (Schweiz) AG,  
Schwerzistraße, 20,  
CH-8807 Freienbach.

Telephone: 41 55 415 44 00  
Fax: 41 55 415 44 15  
e-mail: [epsag@eurotherm.ch](mailto:epsag@eurotherm.ch)  
<http://www.eurotherm.ch>

## United States of America

Eurotherm Recorders Inc.  
741-F Miller Drive  
Leesburg  
VA 20175-8993

Telephone: 1 703 669 1342  
Fax: 1 703 669 1307  
e-mail (Sales): [sales@chessell.com](mailto:sales@chessell.com)  
e-mail (Technical): [support@chessell.com](mailto:support@chessell.com)  
<http://www.chessell.com>



invensys  
**EUROTHERM**

EUROTHERM LIMITED

Faraday Close, Durrington, Worthing, West Sussex, BN13 3PL  
Telephone: 01903 695888 Facsimile: 01903 695666  
e-mail: [info@eurotherm.co.uk](mailto:info@eurotherm.co.uk)  
Website: <http://www.eurotherm.co.uk>





