

User Guide

Model 394

Multi-point circular-chart recorder



invensys

EUROTHERM

Major Functional items

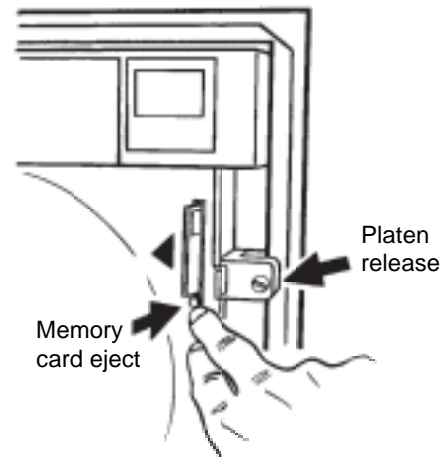
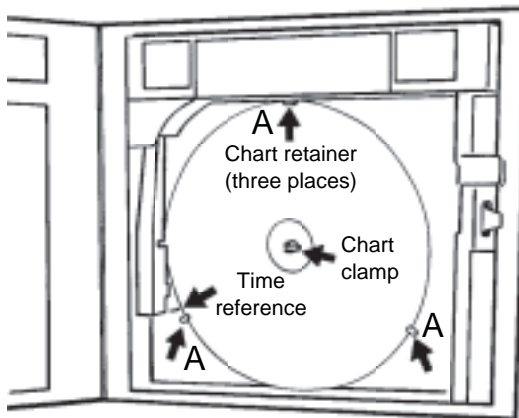
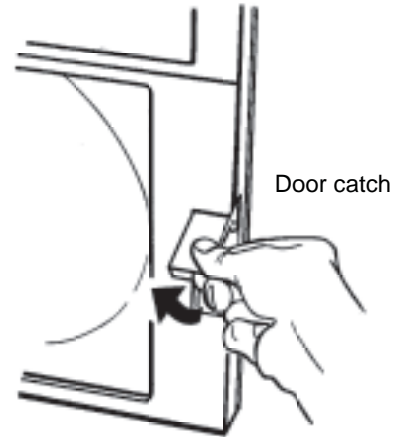
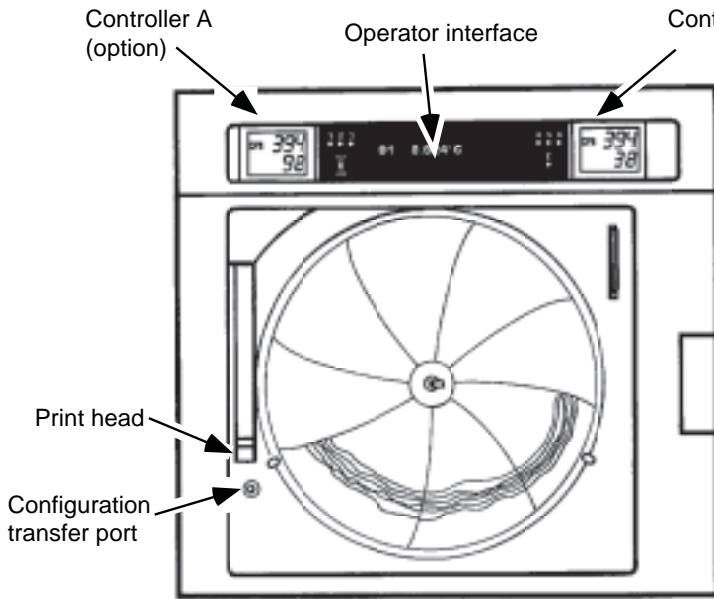

Consumables

Charts	
24-hours/rev	GDTW0394Uxxx
7-days/rev	GDSV0394Uxxx

Print cartridge
LA250280

xxx = n of divisions from centre to edge = 050, 060, 070, 080, 100, 150

Other items

Attenuator (100:1)..... LA244180	PC Configuration tool..... LA246843
Shunt (100Ω).....LA246779UK10	Controller handbook *.....HA025036
Shunt (250Ω).....LA246779UK25	

* One copy supplied with each recorder fitted with controller option.



EUROTHERM

Declaration of Conformity

Manufacturer's name:	Eurotherm Limited
Manufacturer's address	Faraday Close, Worthing, West Sussex, BN13 3PL, United Kingdom.
Product type:	Industrial chart recorder
Model:	394 (Status level B2 or higher)
Safety specification:	EN61010-1: 1993 / A2:1995
EMC emissions specification:	EN50081-2 (Group1; Class A)
EMC immunity specification:	EN50082-2

Eurotherm Limited hereby declares that the above products conform to the safety and EMC specifications listed. Eurotherm Limited further declares that the above products comply with the EMC Directive 89 / 336 / EEC amended by 93 / 68 / EEC, and also with the Low Voltage Directive 73 / 23 / EEC

Signed:

William Davis

Dated: *18th September 2002*

Signed for and on behalf of Eurotherm Limited

William Davis
(General Manager)



IA249986U130 Issue 2 Sep 02

© 2006 Eurotherm Limited

All rights are strictly reserved. No part of this document may be reproduced, stored in a retrieval system or transmitted in any form, by any means, without the prior, written permission of the copyright owner.

Eurotherm Limited reserves the right to alter the specification of its products from time to time without prior notice. Although every effort has been made to ensure the accuracy of the information contained in this manual, it is not warranted or represented by Eurotherm Limited to be a complete or up-to-date description of the product.

CIRCULAR CHART RECORDER USER GUIDE

LIST OF CONTENTS

Section	Page
STATIC ELECTRICITY	9
TERMINOLOGY	9
SAFETY NOTES	10
SYMBOLS USED ON THE RECORDER LABELLING	10
1 INSTALLATION	11
1.1 UNPACKING THE RECORDER	11
1.2 INSTALLATION	11
1.2.1 Mechanical installation	11
PANEL MOUNTING	11
PIPE MOUNTING	11
1.2.2 Electrical installation	11
CONFIGURATION TRANSFER WIRING	11
SUPPLY VOLTAGE (MAINS) WIRING	14
SIGNAL WIRING	15
1.3 CHANGING THE CHART	16
1.4 CHANGING THE CARTRIDGE	17
2 BASIC OPERATION	18
2.1 POWER UP	18
2.2 BACKGROUND DISPLAY	18
2.3 ALARM INDICATION	19
2.4 KEY/DISPLAY FUNCTIONS	19
2.4.1 Keys	19
ALARM ACKNOWLEDGE	19
PAGE UP/DOWN	19
CURSOR	19
SCROLL UP / DOWN KEYS	20
CANCEL	20
ENTER	20
2.4.2 Indicators	20
CHANNEL ALARMS	20
GLOBAL ALARM	20
EDIT/HOLD	20
2.5 CONFIGURATION EXAMPLE	21
2.5.1 Channel inputs/outputs	21
2.5.2 Entering configuration	21
2.5.3 Channel configuration	22
TEMPERATURE UNITS	23
LINEARIZATION TYPE	23
CJC TYPE	23
SCALE PAGE	23
VALUE FORMAT	23
INPUT BREAK RESPONSE	24
OFFSET	24
TAG	24
ALARM TYPE	24
ALARM THRESHOLD (SETPOINT)	25
ALARM JOBS	25
CHECKING THAT THE TRACE IS ON	26

(Continued)

List of contents (Cont.)

Section	Page
3 OPERATOR MENUS.....	27
3.1 INTRODUCTION	27
3.2 TOP LEVEL OPERATOR MENUS	27
3.3 CHART SUBMENU	27
3.3.1 Chart on/off	28
CHART ALIGN	28
3.3.2 Logs	29
OPERATOR INITIATION	29
JOB INITIATION	29
AUTOMATIC LOGGING	29
3.3.3 Scale print (Dump Scales)	29
3.4 ALARM SUMMARY PAGE	29
3.4.1 Display interpretation	30
3.5 ALARM SETUP PAGE	30
3.6 ACTION	30
3.7 CLOCK	30
3.7.1 Back-up battery	31
3.8 SYSTEM ERROR	31
3.9 CONFIGURATION	31
3.10 CALIBRATE CHART	32
3.11 OPERATOR MENU SUMMARY	33
4 CONFIGURATION	35
4.1 INTRODUCTION	35
4.1.1 Password	35
4.1.2 Text entry	35
CHARACTER SET	35
4.1.3 Options	37
4.1.4 Logs 1 and 2	37
4.1.5 Jobs	37
4.2 CONFIGURATION TECHNIQUES	39
4.3 INSTRUMENT CONFIGURATION	40
4.3.1 Password	40
4.3.2 Language	40
4.3.3 Remote CJ Channel	40
4.3.4 Remote CJ units	40
4.3.5 Instrument tag	40
4.4 CHART CONFIGURATION	41
4.4.1 Chart speed	41
4.4.2 User chart speed	41
4.4.3 Stop After One Revolution	42
4.4.4 Log intervals A and B	42
4.4.5 Printing	42
TIME/DATE/CHART SPEED	42
SCALE	42
MESSAGES	42
4.4.6 Adaptive recording	42

List of contents (Cont.)

Section	Page
4.5 CHANNEL CONFIGURATION	43
4.5.1 Range configuration	43
INPUT TYPE	43
INPUT RANGE	43
SHUNT VALUE	43
INPUT UNITS	43
LINEARISATION TYPE	44
CJC TYPE	45
SCALED	45
VALUE FORMAT	45
DAMPING	45
BREAK RESPONSE	45
OPEN / CLOSED	46
TEST WAVEFORMS	46
TAG	46
4.5.2 Alarm configuration	47
SETPOINT CONFIGURATION	47
ALARM PARAMETERS	49
ALARM JOBS	49
4.5.3 Trace configuration	50
TRACE	50
COLOUR	50
LINE THICKENING	50
SPAN A / SPAN B	50
4.6 GROUP CONFIGURATION	52
4.6.1 Log groups 1,2	52
4.6.2 DV Group	53
4.6.3 Display Group	53
4.7 OPERATOR ACTION CONFIGURATION	53
4.8 CLOCK CONFIGURATION	53
4.8.1 Set Time	53
4.8.2 Set Date	53
FORMAT	54
4.9 MESSAGE CONFIGURATION	54
4.9.1 Embedded sequences	54
ONE PART SEQUENCES	54
TWO PART SEQUENCES	54
4.10 INTERNAL EVENTS	55
4.10.1 Event sources	55
4.11 CONFIGURATION TRANSFER	57
↓ TO SAVE CONFIG	57
↓ TO RESTORE CONFIG	57
BAUD RATE	57
4.12 OPERATOR ACCESS	58
4.13 ADJUST	59
4.13.1 Input adjust	59
4.13.2 Chart adjust	60
4.14 DEFAULT CONFIGURATION	60
4.15 CONFIGURATION MENU SUMMARY	61

List of contents (Cont.)

Section	Page
5 RELAY OUTPUT OPTION	63
5.1 INTRODUCTION	63
5.1.1 Configuration	63
JOBS	63
5.1.2 Relay specification	63
5.2 RELAY WIRING	64
5.2.1 Six change-over (also called Form C or SPDT) relays board	64
6 ANALOG OUTPUT (RETRANSMISSION) OPTION	65
6.1 INTRODUCTION	65
6.2 SPECIFICATION	65
6.3 WIRING	66
6.4 CONFIGURATION PAGES	66
6.5 OUTPUT ADJUST	68
7 MATHS PACK OPTION	69
7.1 INTRODUCTION	69
7.1.1 Groups	69
7.1.2 Jobs	69
7.1.3 Operator pages	70
7.2 EQUATIONS	70
7.2.1 Level 1 equations	70
CONSTANT	70
COPY	70
ADD	70
SUBTRACT	70
MULTIPLY	70
DIVIDE	70
MODULUS	70
7.2.2 Level 2 equations	71
SQUARE ROOT	71
CHANNEL AVERAGE	71
GROUP AVERAGE	71
ROLLING AVERAGE	71
E TO THE POWER	71
NATURAL LOG	71
10 TO THE POWER	71
LOG BASE 10	71
RATE OF CHANGE	72
SAMPLE AND HOLD	72
CHANNEL MINIMUM	72
DV GROUP LATCH MIN	72
DV GROUP CONT MIN	72
CHANNEL MAXIMUM	72
DV GROUP LATCH MAX	72
DV GROUP CONT MAX	72
THIRD ORDER POLYNOMIAL	72
RELATIVE HUMIDITY	73
F VALUE	73
MASS FLOW LINEAR	74
MASS FLOW SQUARE ROOT	76
ZIRCONIA PROBES	77
SWITCH	78

List of contents (Cont.)

Section	Page
7.2.2 LEVEL 2 EQUATIONS (CONT.)	
HIGH SELECT	78
LOW SELECT	78
STOPWATCH	78
TIME STAMP	79
OXYGEN (O ₂) CORRECTION	79
PERCENTILE	80
7.3 CONFIGURATION	81
MATHS PACK UNIQUE PARAMETERS	81
8 TOTALISERS, COUNTERS AND TIMERS.....	85
8.1 INTRODUCTION.....	85
8.2 TOTALISERS	85
8.2.1 Source types	85
8.2.2 Alarms	85
8.2.3 Display	85
8.2.4 Tracing on the chart (maths pack level 1 required)	85
8.2.5 Operator pages	85
8.2.6 Totalizer configuration	86
ALARM PAGES	87
8.3 TOTALIZER COUNTER OUTPUT	88
8.4 COUNTERS	88
8.4.1 Introduction.....	88
8.4.2 Tracing on the chart (maths pack level 1 required)	88
8.4.3 Display.....	88
8.4.3 Operator pages	88
8.4.4 Configuration	89
ALARM PAGES	89
8.5 TIMERS	90
8.5.1 Introduction.....	90
8.5.2 Operator pages	90
8.5.3 Configuration	90
JOBS PAGES	91
8.5.4 Timer examples	91
9 CONTROLLERS OPTION	92
9.1 INTRODUCTION.....	92
9.2 VIEWING ON RECORDER CHANNEL.....	92
9.3 WIRING.....	92
9.3.1 Output and PV data	92
9.3.2 User input (T/C, RTD, mA, volts or mV)	92
9.4 SPECIFICATION	94

List of contents (Cont.)

Section	Page
10 CUSTOM LINEARISATION OPTION	95
10.1 INTRODUCTION	95
10.2 CONFIGURATION PAGES	95
11 SERIAL COMMUNICATIONS OPTION	96
11.1 INTRODUCTION	96
11.1.1 Safety isolation specification	96
11.2 WIRING	96
11.2.1 Pinout	96
11.2.2 Termination and Biasing	97
HOST COMPUTER	97
11.3 CONFIGURATION PAGES	98
11.4 GOULD MODICON MODBUS PROTOCOL	99
11.4.1 Introduction	99
11.4.2 Channel addressing	99
11.4.3 Reading analog inputs	99
11.4.4 Function codes	100
11.5 XMODEM TRANSFER	102
12 MEMORY CARD OPTION	103
12.1 INTRODUCTION	103
12.2 MEMORY CARD INSERTION	103
12.2.1 Card formatting	105
12.2.2 Changing cards	105
12.3 CONFIGURATION SAVE AND RESTORE	106
12.3.1 Save	106
12.3.2 Restore	106
12.4 DATA LOGGING (ARCHIVE)	107
12.4.1 Archive Configuration	107
JOBS	108
12.4.2 Archive interval	110
12.5 OPERATOR ACCESS	110
12.6 MEMORY CARD GENERAL FUNCTIONS	111
12.6.1 Directory	111
12.6.2 Delete	111
12.6.3 Card status	112
12.6.4 Automatic file deletion	112
12.7 ARCHIVE FILES	112
12.7.1 Text file names	113
12.7.2 Hourly file names	113
12.7.3 Daily file names	113
12.7.4 Counter file names	113
12.7.5 File name extensions	113
12.7.6 Rules for creation of files	114
12.8 OTHER INFORMATION	114
12.8.1 Event sources	114
12.8.2 System errors	114
12.8.3 Error messages	114
12.9 MEMORY CARD CONFIGURATION MENU OVERVIEW	115

List of contents (Cont.)

Section	Page
13 TRANSMITTER POWER SUPPLY OPTION.....	116
13.1 INTRODUCTION	116
13.1.1 Fuses	116
13.1.2 Safety isolation specification	116
13.2 SIGNAL WIRING	117
14 REFERENCE.....	119
14.1 COSHH	119
14.1.1 Printheads	119
14.1.2 Batteries	120
14.2 ERROR MESSAGES	121
14.2.1 Invalid configuration	121
14.2.2 Failure to adjust channel (Adj fail on ch NN)	121
14.2.3 Input adjust not available (I/P Adj n/a on ch NN)	121
14.2.4 Printer must be off line	121
14.3 LIST OF EFFECTIVE PAGES	122
14.4 GLOSSARY OF TERMS	123
ANNEX A TECHNICAL SPECIFICATION	127
A1 TECHNICAL SPECIFICATION (RECORDER)	128
A2 TECHNICAL SPECIFICATION (INPUT BOARD)	129
INDEX	131

This page is deliberately left blank



STATIC ELECTRICITY

High voltages (tens of kilo-volts) can be generated on the human skin through a number of mechanisms, such as friction between different materials (e.g. nylon and skin), and separation of similar materials (e.g. masking tape, nylon sheet). The gate-oxide region of all metal oxide semiconductors (MOS) is extremely thin, and can be damaged by voltages as low as 60 Volts. Modern MOS devices have built-in clamp diodes which reduce the incidence of obvious static damage considerably. It is possible however, even with such clamping diodes, to produce a small rupture in the oxide layer. This might not destroy the device immediately, but it may result in a gradual reduction in the performance of the device until, eventually, it fails.

For this reason, the following precautions should be taken when handling any recorder circuit board.

1. Personnel handling MOS devices, or circuit boards containing them, should wear antistatic materials such as cotton. Nylon clothing should be avoided.
2. All bench tops should be covered with conductive material (10^4 to 10^5 Ohms per square) maintained at the recorder chassis potential.
3. Circuit boards removed from a recorder should be placed into a static-safe bag, initially at the recorder chassis potential, for storage. Before re-fitting the board, the containing bag should again be returned to the recorder chassis potential.
4. Personnel handling MOS devices, or boards containing them, should wear a wrist strap connected (via a safety resistor) to the bench top, or if appropriate, to a suitable grounding point on the rack.
5. Leads of MOS devices removed from circuit should be shorted together using conductive foam or similar.
6. MOS devices should not be extracted from or inserted into circuit whilst the circuit board has power applied.

TERMINOLOGY

Antistatic

This term means that the material in question does not of itself generate static electricity. Such materials do not afford protection against external electric fields.

Static safe

This means that the material in question:

- a) does not generate static electricity, and
- b) any device enclosed in such material is safe from the effects of external electric fields.

SAFETY NOTES

1. Before any other connection is made, the protective earth ground terminal  shall be connected to a protective conductor. The supply voltage (mains) wiring must be terminated in such a way that, should it slip in the cable clamp, the Earth ground wire would be the last wire to become disconnected.
2. In the case of portable equipment, the protective earth ground terminal must remain connected (even if the recorder is isolated from the supply voltage), if any of the I/O circuits are connected to hazardous voltages*.

WARNING!







Any interruption of the protective conductor inside or outside the apparatus, or disconnection of the protective earth ground terminal is likely to make the apparatus dangerous under some fault conditions. Intentional interruption is prohibited.

3. The line voltage fuse within the power supply unit is not replaceable. If it is suspected that the fuse is faulty, the manufacturer's local service center should be contacted for advice.
4. Whenever it is likely that protection has been impaired, the unit shall be made inoperative and secured against unintended operation. The nearest manufacturer's service center should be consulted for advice.
5. A switch or circuit breaker shall be included when installing this instrument. It shall be in close proximity to the instrument and within easy reach of an operator. It shall be marked to indicate that it will disconnect this instrument.
6. Any adjustment, maintenance and repair of the opened apparatus under voltage, should be avoided as far as possible and, if inevitable, shall be carried out only by a skilled person who is aware of the hazard involved.
7. Where conductive pollution (e.g. condensation, carbon dust) is likely, adequate air conditioning/filtering/sealing etc. must be installed in the recorder enclosure.
8. Signal and supply voltage wiring should be kept separate from one another. Where this is impractical, shielded cables should be used for the signal wiring. Where signal wiring is carrying (or could carry, under fault conditions) hazardous voltages *, double insulation should be used.
9. If the equipment is used in a manner not specified by the manufacturer, the protection provided by the equipment might be impaired.
10. The battery is not individually replaceable. If the battery does not function, consult the manufacturer for service information.

* A full definition of 'Hazardous' Voltages appears under 'Hazardous Live' in BS EN61010. Briefly, under normal operating conditions Hazardous voltage levels are defined as >30V RMS (42.4V peak) or >60V dc.

SYMBOLS USED ON THE RECORDER LABELLING

One or more of the symbols below may appear on the recorder labelling.

	Refer to the Manual for instructions
	Protective Earth
	This recorder for ac supply only
	This recorder for dc supply only.
	This recorder for either ac or dc supply
	Risk of electric shock

1 INSTALLATION

1.1 UNPACKING THE RECORDER

The recorder is despatched in a special pack designed to give adequate protection during transit. Should the outer box show signs of damage, it should be opened immediately and the recorder examined. If there is evidence of damage, the instrument should not be operated and the local representative contacted for instructions. After the recorder has been removed from its packing, the packing should be examined to ensure that all accessories and documentation have been removed. Once the recorder has been installed, any internal packing should be removed, and stored with the external packing against future transport requirements.

1.2 INSTALLATION

1.2.1 Mechanical installation

Mechanical installation details are shown in figure 1.2.1

PANEL MOUNTING

The recorder is inserted through the panel aperture from the front of the panel. With the weight of the recorder supported, the recorder is secured using the two clamp brackets supplied, either at the top and bottom or at the right and left sides of the recorder.

PIPE MOUNTING

Mounting brackets to suit a 50mm (2 inch) pipe are also available.

1.2.2 Electrical installation

Details for connecting the line supply and for signal wiring are shown in figure 1.2.2. A user supplied and mounted switch for the supply voltage must be included with the installation.

CONFIGURATION TRANSFER WIRING

Wiring for the configuration port jack plug is as shown below. See section 4.11 for details of the configuration transfer facility.

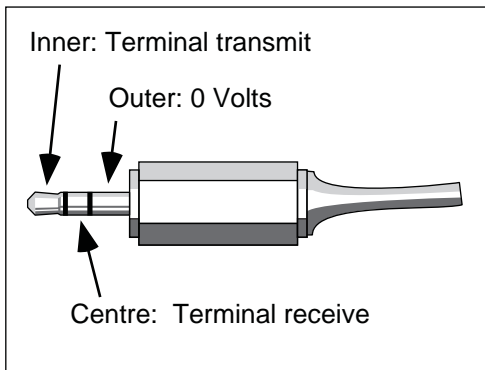

Jack plug wiring for transfer with host computer/dumb terminal

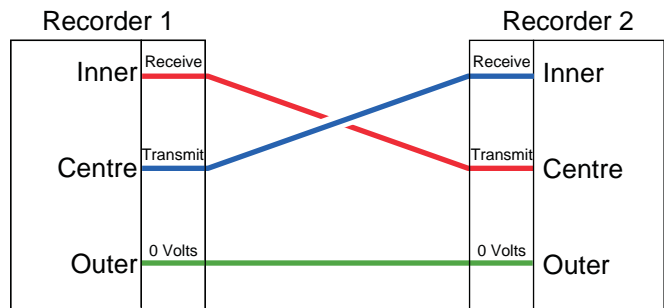

Jack - to - jack wiring for transfer between recorders

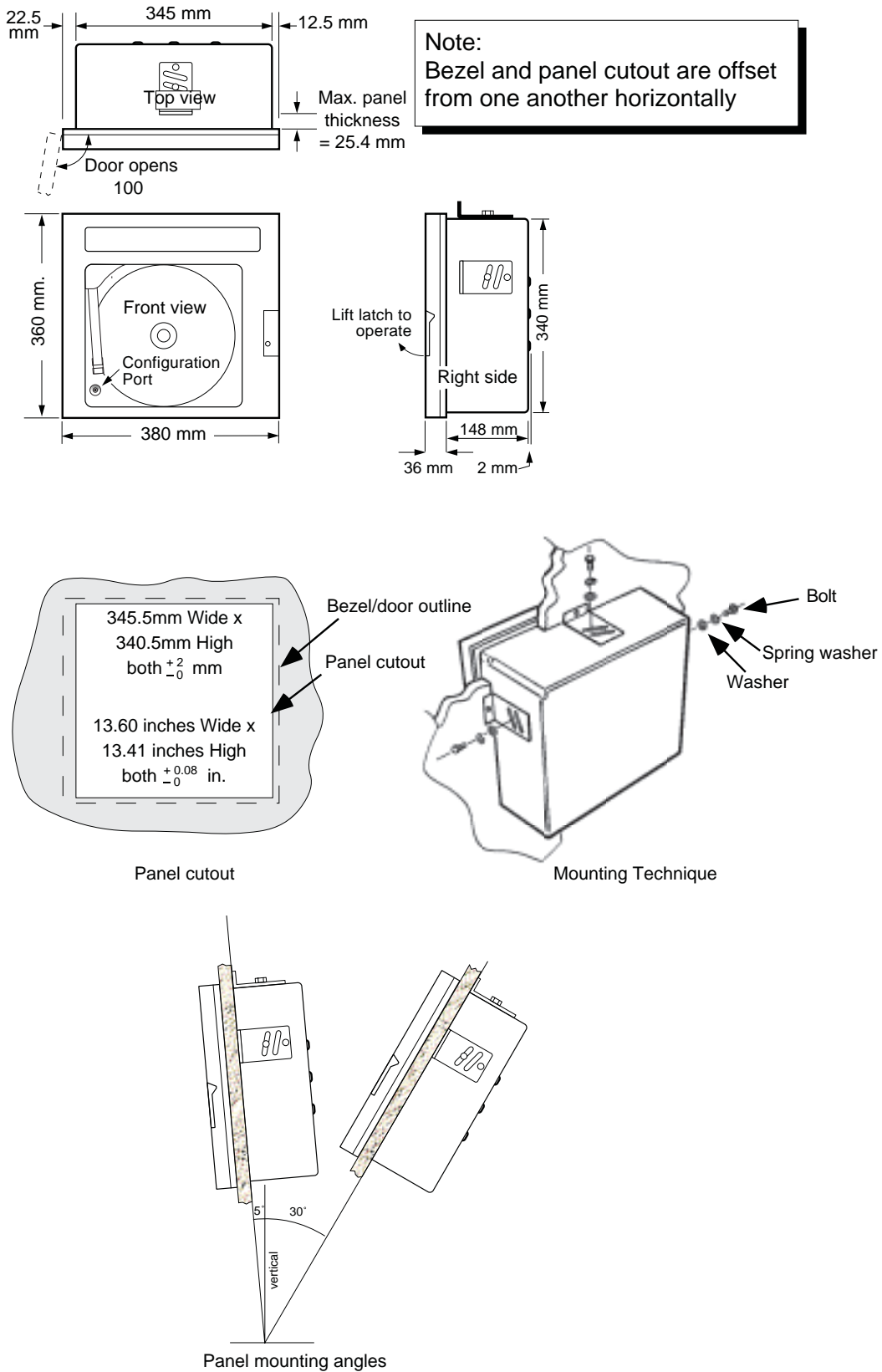

Figure 1.2.1 Mechanical installation

1.2.2 ELECTRICAL INSTALLATION (Cont.)

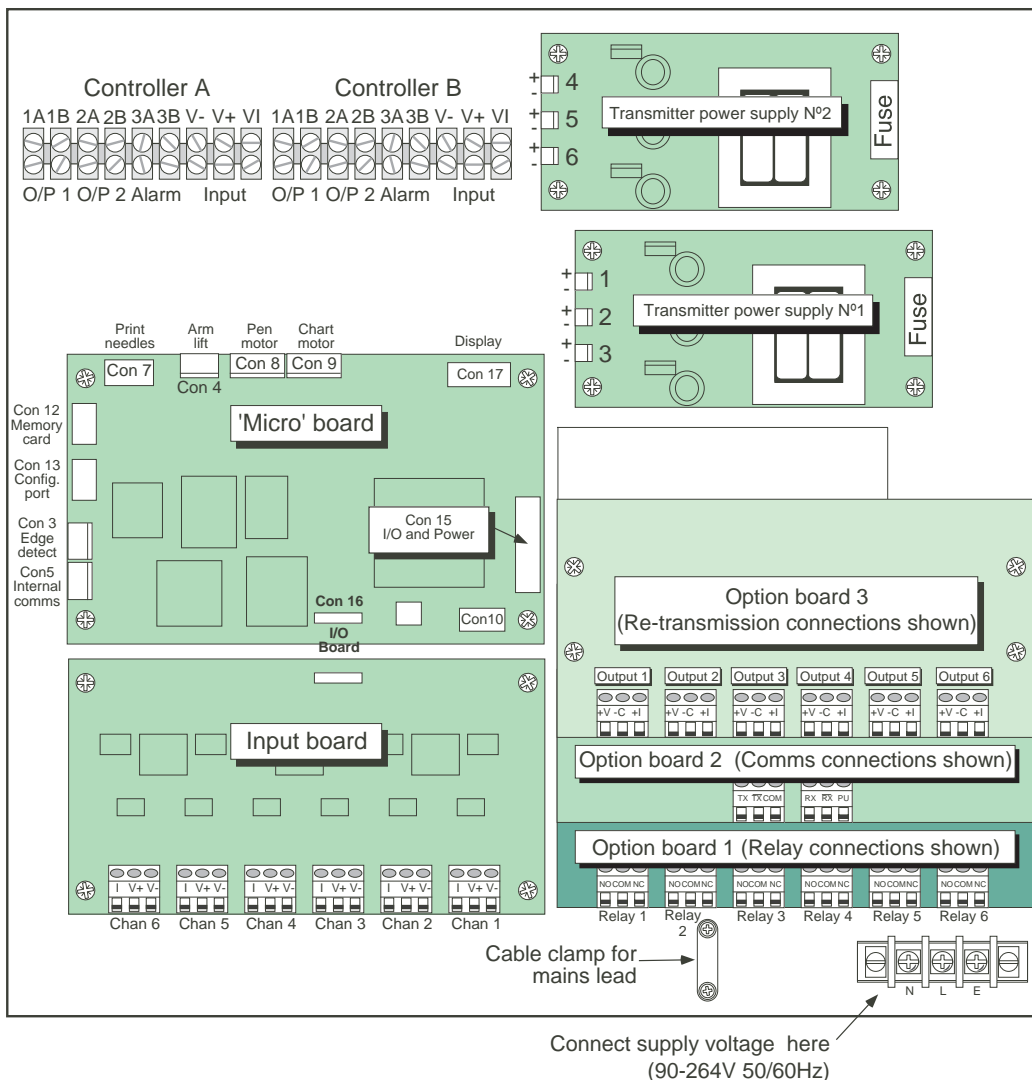
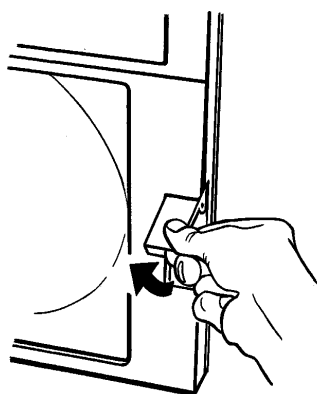

Figure 1.2.2 Electrical installation - overview

Notes:

1. Access to terminals is by opening the door, then undoing the securing screw to release the platen.
2. Option boards are shown as 1 = relays, 2 = serial communications, 3 = retransmission (analogue output). In fact any option board can be fitted in any of the three positions. Up to three relay boards can be fitted, if no other options are fitted.



Lift latch to release door catch

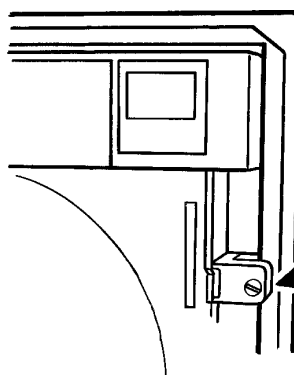

Undo this screw to release platen.

1.2.2 ELECTRICAL INSTALLATION (Cont.)

SUPPLY VOLTAGE (MAINS) WIRING

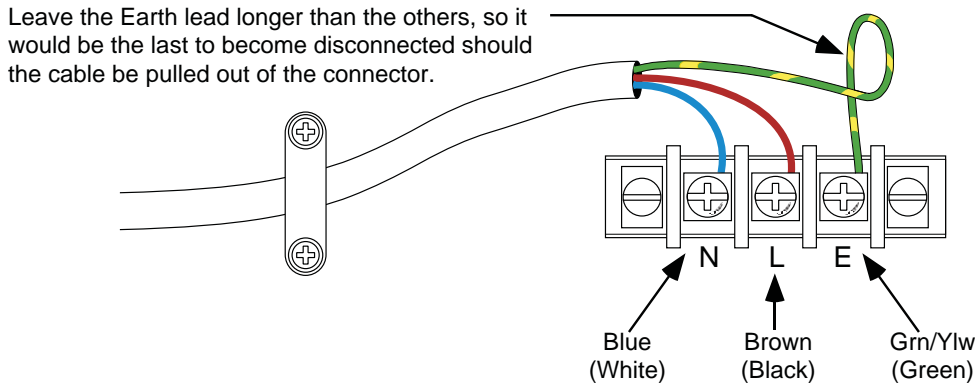

Figure 1.2.2b Supply voltage wiring

The supply voltage cable is terminated at the terminal block located near the bottom right-hand corner of the case (see figure 1.2.2a). Care should be taken to ensure that only the earth ground wire (green or green with a yellow stripe) is connected to the Earth (right-most) terminal.

The fuse in the main recorder power supply is not user replaceable. If fuse may have been blown, consult manufacturer for service information.

Caution

Although the recorder is designed to work from any 50 or 60Hz voltage between 90 and 264V, the transmitter power supply option is not. When sold with a new order, the transmitter power supply will come with the correct links and fuse for the specified line voltage. When supplied as a retrofit option, or if the supply voltage to the recorder changes, each transmitter power supply board must have its links and fuse correctly selected, or the fuse may rupture when power is applied. Figure 1.2.2c gives details of links and fuse types.

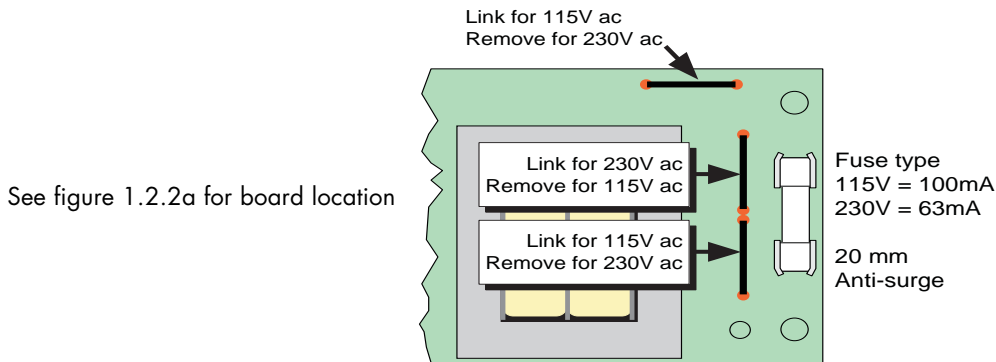

Figure 1.2.2c Transmitter Power Supply link/fuse details

1.2.2 ELECTRICAL INSTALLATION (Cont.)

SIGNAL WIRING

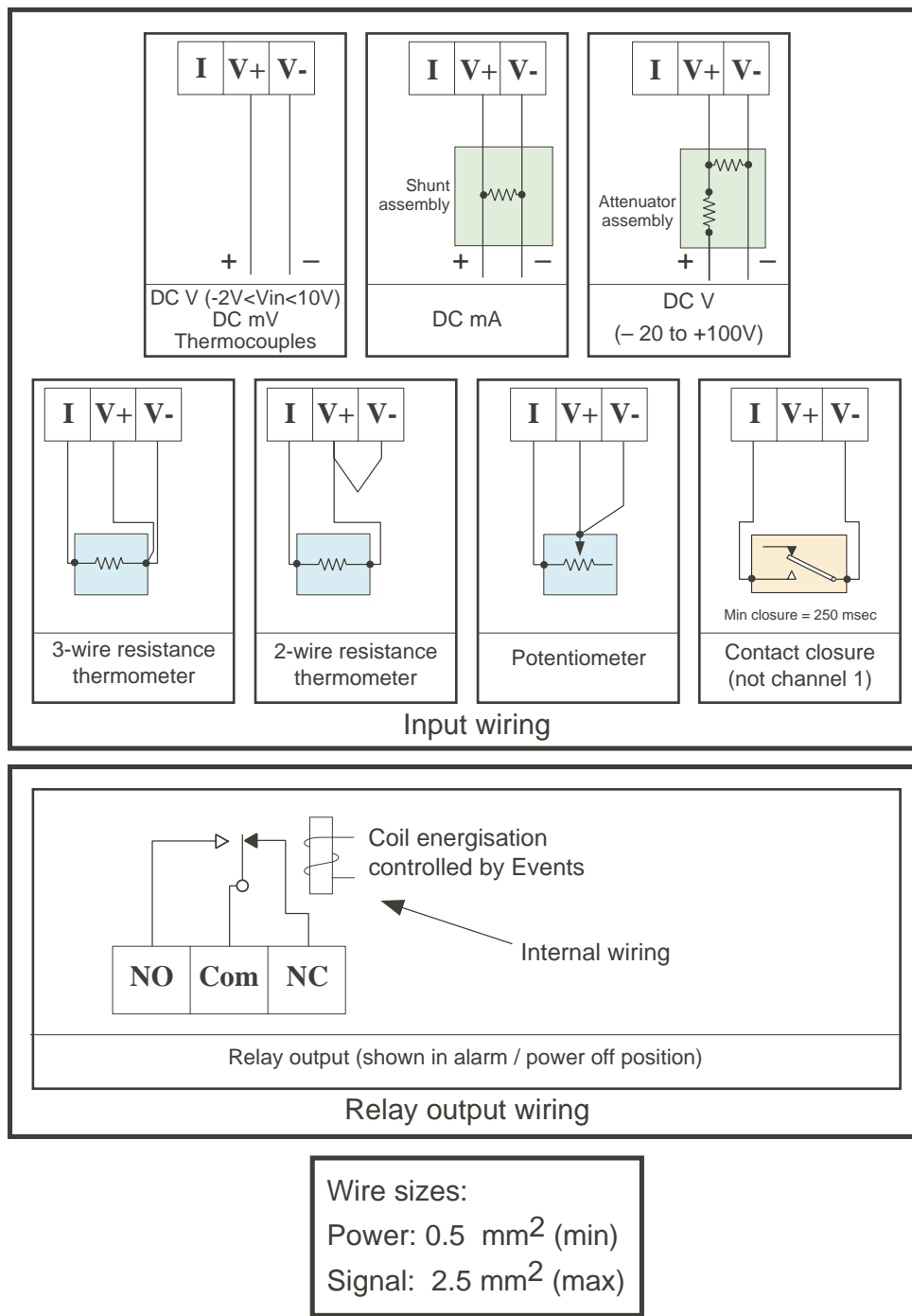

Figure 1.2.2d Input / output wiring

Note: See section 11 for Serial communications and section 6 for analogue output (retransmission) wiring. For controller wiring details see section 9 and the controller handbook.

1.3 CHANGING THE CHART

Open the recorder door (fig 1.3a) and operate the cancel (x) key to call the **Op: Display** page, then use the page key to call the **Op: Chart** page.

Operate the 'Enter' key twice to switch the chart drive off.

If there is currently no chart fitted, ignore the rest of this paragraph. If there is a chart fitted, Lift the paper locking tab at the center of the chart hub ('A' in figure 1.3b), and remove the old chart by lifting it out from under the hold-down tabs ('B') and off the hub.

Place the new chart under the hold-down tabs ('B' in figure 1.3b) and onto the hub ('A') **WITHOUT YET LOWERING THE LOCKING TAB**. Rotate the chart until the current as time printed on the chart is just clockwise (i.e above) the time reference mark ('C' in the figure). Lower the locking tab onto the chart.

Use the page key to call the **↵ to align** page. Press repeatedly, or hold continuously the enter key to rotate the chart counter-clockwise until the current time, as printed on the chart, is aligned with the time reference point.

Carry out the alignment procedure described in section 3.10 before returning the recorder to service.

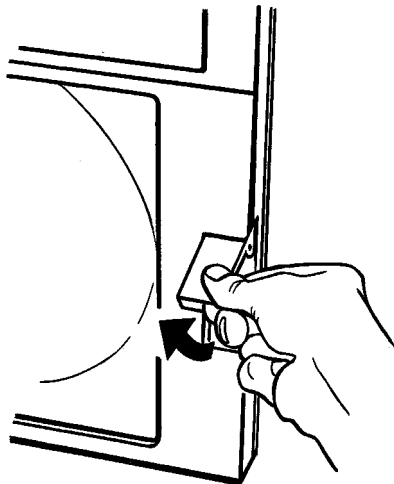
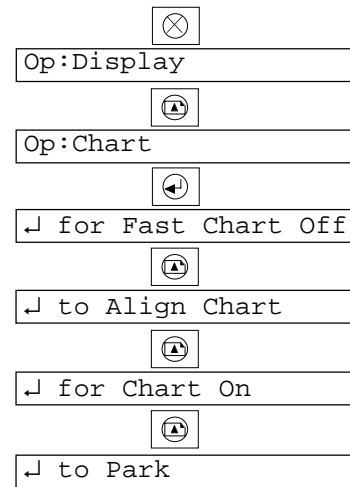

Fig 1.3a Open the recorder door

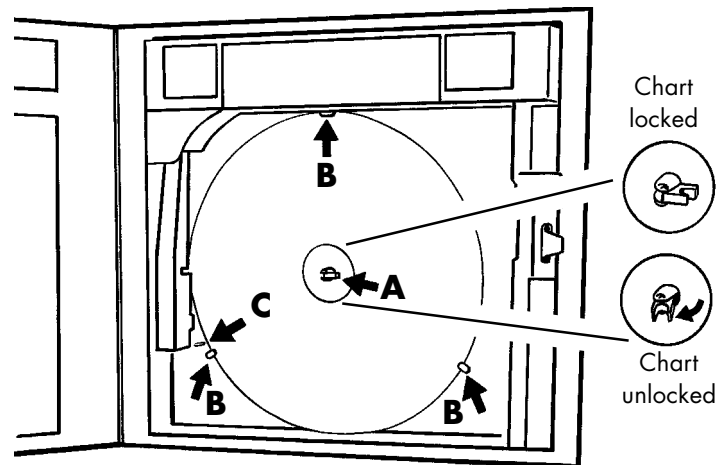

Fig 1.3b Change chart

1.4 CHANGING THE CARTRIDGE

Note: Care should be taken to avoid cartridge ink contact with skin or clothing

Before changing the cartridge, switch the chart drive off as described in section 1.3 above. Then use the page key twice, then the Enter key, to park the printhead.

Lift the printhead arm and pull the print cartridge down and away (figure 1.4). Fit the new cartridge and lower the arm.

Use the page key repeatedly until the page appears. Operation of the enter key re-starts tracing.

Note: If the arm is lifted during normal tracing, the pen drive will stop, but the chart will continue to rotate. Subsequent lowering of the pen will set the pen to its normal rest position, before tracing restarts. When the printhead is lowered, the chart backs up 2-3 degrees and then comes forward to its original position to ensure chart motor start-up time accuracy.

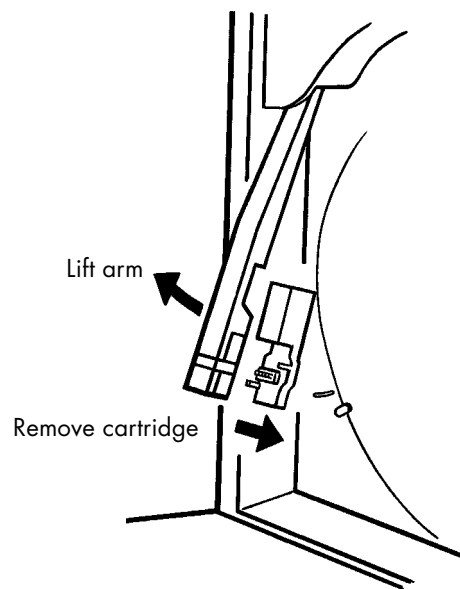

Figure 1.4 Changing the cartridge

2 BASIC OPERATION

This section is designed to help you as a new user to understand the display and key operations. After the display and key descriptions, an example configuration is given to show you how to set up an input channel to a known set of parameters, so you can start recording your own traces with the minimum of effort. Only those items which are necessary to get you going are explained; for full information about the Operator and Configuration display see sections 3 and 4 respectively.

2.1 POWER UP

At power up, a power-on message can be printed on the chart giving any of: time, date, and chart speed. Which (if any) of these is required is set up in Chart Configuration (section 4.4) For example:-

```
09:15 29/02/96 12 Hour Chart
or
29/02/96 7 Day Chart
```

See sections 3.7 and 3.8 if a system error is indicated.

2.2 BACKGROUND DISPLAY

After initialization is complete, the display enters what is called a 'background' display, showing the value of a channel in a format similar to that shown below. If this is the first switch-on, or if the recorder has not been configured, the channel will be OFF.

Initially, the first channel on display is measuring channel 1. This remains on display for 5 seconds, after which channel 2 appears. Channels 'scroll' in this manner until all input channels have been displayed, after which, if the display group has been edited to include them (section 4.6.3) any option channels (derived variables, totalisers and counters) will be scrolled through in the same manner. When all channels have been scrolled-through, input channel 1 is returned to.

01 1.2345 Units	(Measuring channel)
D01 1.2345 Units	(Derived (maths) channel)
T1 123456789 Units	(Totaliser)
C1 12345678 Units	(Counter)

By operating the page up/down keys, the display can be made to show alarm types or the channel identifier (tag) instead of its current value. When either of these alternative displays are selected, the relevant channel is held (i.e. the normal scrolling process is stopped).

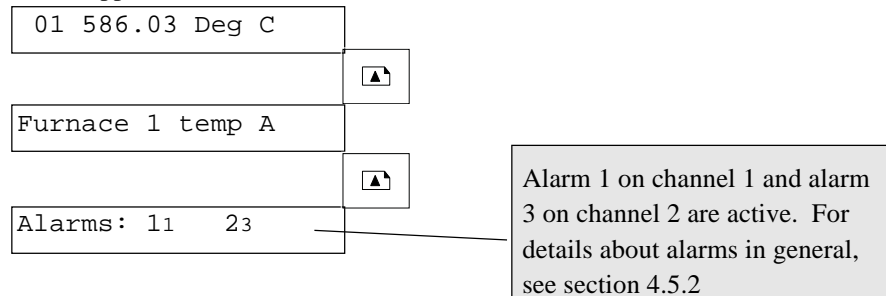

2.3 ALARM INDICATION

Each of the six input channels has its own LED indicator on the display. A further alarm icon situated to the left of the display line indicates whenever there is an active alarm. The symbols flash until the alarm is acknowledged or are steadily illuminated if the alarms are still active but have been acknowledged.

Alarms can be acknowledged at any time by using the Alarm acknowledge key (the left-most key of the eight). Figure 2.4 shows the operator interface with the locations of the channel alarm indicators and the operating keys.

2.4 KEY/DISPLAY FUNCTIONS

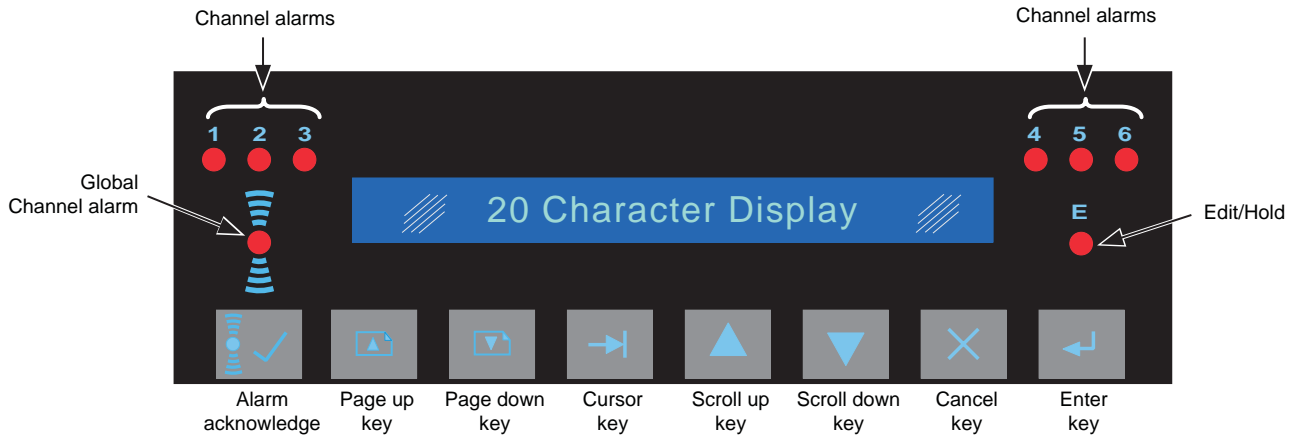

Figure 2.4 Operator interface

2.4.1 Keys

ALARM ACKNOWLEDGE

This key acknowledges all active, unacknowledged alarms.

PAGE UP/DOWN

The Page up and down keys are used

- a. to move round the Operator and Configuration top level menus
- b. to move round sub menus (e.g. Operator Chart submenu - section 3.3)

CURSOR

The cursor key can be used in background mode to stop the normal scrolling-through of channels' values i.e. to display a single channel's value continuously (Channel hold) until the cursor key is operated again. The 'E' LED is illuminated while channel hold is in operation.

In operator and configuration pages, the cursor key is used to move from field to field where there is more than one item whose value can be changed. The cursor position is shown by the selected field's flashing on and off. For example, the Log interval page (part of chart configuration) has both hours and minutes fields (shown underlined below) which are moved between using the cursor.

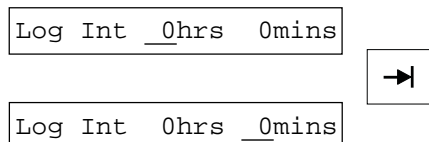

2.4.1 KEYS (Cont.)

SCROLL UP / DOWN KEYS

This key is used

- a. To scroll through text characters when entering text strings.
- b. To enter numeric values.
- c. To scroll through all menu items associated with a parameter (e.g. thermocouple types).

CANCEL

This is used

- a. To enter the Operator menus from the background display.
- b. To cancel all changes made since the last operation of the 'Enter' key (described below).
- c. To move you to the next highest menu level.

ENTER

This is used

- a. To return to the background display from the Op:Display page.
- b. To initiate changes in the Operator menus (section 3)
- c. To confirm changes made to configuration.
- d. To enter sub menus (i.e. to go to the next lowest menu level).

2.4.2 Indicators

CHANNEL ALARMS

Each input channel has a dedicated LED indicator to show alarm status. The LED comes on (flashing) when any one of the four alarms are triggered and stays on for a period determined by the type of alarm (section 4.5.2).

For latching alarms, the LED will stay illuminated until the cause (trigger) of the alarm has returned to a non-alarm state AND the alarm has been acknowledged. If the alarm trigger is still active when the alarm is acknowledged, the LED will stop flashing and remain steadily illuminated until the trigger goes inactive. If the alarm trigger has already returned to a non-active state by the time the alarm is acknowledged, then the LED will extinguish immediately on acknowledgement.

For non-latching alarms, the LED will be illuminated (flashing if unacknowledged) only until the trigger returns to a non active state.

GLOBAL ALARM

This alarm symbol to the left of the display line becomes active if there is any alarm which is active (on input and derived channels, totalizers etc.). Again the icon flashes if the alarm is unacknowledged.

EDIT/HOLD

During operation it is possible to hold one channel permanently on display (i.e. you can disable the normal scrolling-through of all the items in the display group) by operating the cursor (right arrow) key while the required channel is on display.

During configuration, the 'E' indicator illuminates if a change has been made to the configuration, which has not been written to the recorder memory by operation of the 'Enter' key.

2.5 CONFIGURATION EXAMPLE

This section gives you a step-by-step guide to the basic configuration of a single channel (N°2) to an imaginary set of input conditions. If you are new to recorders, it is recommended that you first follow this example, and then modify it to suit your own particular requirements. Section 4.5 gives details for each entry.

Notes

1. Because of the difficulties involved in representing items which flash on and off, the cursor position is shown in this manual by an underline character.
2. The 'Page up' key is used in this description to scroll through page menus. The page down key can also be used, but the scroll order is reversed and will therefore not match the description.

2.5.1 Channel inputs/outputs

Before starting to configure any part of the recorder, it is essential that you know exactly what you want it to do with the input signal you are supplying it with. For our channel, a list of parameters can be written as follows:

Channel number	2
Input range	0 to 1000 degrees C
Input type	Type J thermocouple
Input break response	Drive high
Trace	On
Tag	Furnace1 tempA
Alarm	Tripped immediately if temperature exceeds 780 degrees C. Remains active until acknowledged. Log channels 1 to 6 on the chart on alarm.

2.5.2 Entering configuration

From the background display, operate the Cancel key



01 OFF

The data display area changes to the first of the operator pages.

Op: Display

Repeated operation of the Page up key scrolls through the top level operator pages. (The page down key scrolls in the opposite direction, but is omitted here for the sake of clarity.)

Op:Chart

Op:Alarm Summary

Op:Channel 1 Alarm 1

Op: Action

Op:Clock

Op:System Error

Op:Configuration

Password 00000



When the configuration page is reached, operate the 'Enter' key



2.5.2 Entering Configuration (Cont.)

The password is set to '10' at the factory. The password can be edited in Instrument Configuration.

To enter '10', press the cursor key three times, then the up arrow and 'enter' keys.

Password 00000	→
Password 00000	
Password 00000	→
Password 00000	▲
Password 00010	↵
Conf: Instrument	▲
Conf:Chart	▲
Conf:Channel 1	▲
Conf:Channel 2	↵
Channel : Range	↵
I/P Type Off	▲
I/P type T/C	▲
	▲
I/P Range Lo 0.00	▲
I/P Range Hi 0.00	▲
I/P Range Hi 1000.0	→

2.5.3 Channel configuration

Operate the Page up key twice, to call the top level channel configuration page.

Use the up arrow key to change the channel number to '2' and operate the 'Enter' key.

Use the Enter key again to enter 'Range' configuration.

Operate the up arrow key to change 'Off' to 'T/C' (Thermocouple). Note the other input type choices.

The 'E' LED illuminates to remind you that you have made a change which has not yet been entered into the data base.

Operate the Page up key to call the Range low page.

The low range is 0 as required, so operate the page key again to call the Range High page

Enter the value 1000 as follows:

1. Operate the up arrow key until 'I' appears in the display.
2. Operate the cursor key, and repeat step 1, but stop when '0' appears in the display.
3. Repeat step 2.
4. Repeat step 2.
- 5 Repeat step 2 but stop when the decimal point appears.

Note: If you do not enter the decimal point, the recorder will interpret the entry as 100000

2.5.3 CHANNEL CONFIGURATION (Cont.)

TEMPERATURE UNITS

Operate the page key to call the input units page

Units are °C as required. Other units (°F, K or R could be scrolled to using the arrow keys)

Operate the Page up key to call the linearisation type page.

LINEARIZATION TYPE

Use the up arrow key to scroll from Type B through to Type J thermocouple.

Operate the Page up key to call the CJC page.

CJC TYPE

Use the up arrow key to scroll from 'Off' to 'Internal'. This is the usual CJC type choice.

SCALE PAGE

Use the page key to call the scaling page. As our scale range is the same as the input range, we can leave it 'Unscaled' and continue by operating the Page up key.

Scaling is used where an input signal (e.g. 4-20 mA) is used to represent another type of input (e.g. 0-500 gal/min), or where, a potentiometer wiper voltage may be required to appear as, say, 0 to 100% instead of 0-1 Volts.

VALUE FORMAT

This page allows us to set the position of the decimal point for display.

Use the up arrow key to move the decimal point to our required position (two decimal places)

'E'	I/P Units °C	▲
'E'	Lin Type <u>Type B</u>	▲
'E'	Lin Type <u>Type C</u>	▲
'E'	Lin Type <u>Type E</u>	▲
'E'	Lin Type <u>Type J</u>	▲
'E'	CJC Type <u>Off</u>	▲
'E'	CJC Type <u>Internal</u>	▲
'E'	Unscaled	▲
'E'	Val Format <u>XXXXX.</u>	▲
'E'	Val Format <u>XXXX.X</u>	▲
'E'	Val Format <u>XXX.XX</u>	▲

2.5.3 CHANNEL CONFIGURATION (Cont.)

INPUT BREAK RESPONSE

Use the Page up key twice to call the Break Response page. This page allows us to set Drive high, such that if the wiring to the thermocouple breaks, the pen will move to the outer edge of the chart and trace at Full Scale, thus making it obvious that there is a problem.

OFFSET

Used to add a fixed value (in engineering units) to measurements. This is normally set to 0.0.

TAG

This page allows entry of a 14-character text string to describe the channel. The tag can appear at the display and in logs.

Use of the up and down arrow keys allows us to scroll through the available character set for whichever of the 14 characters is currently flashing. The cursor key is used to move you along the string to the position to be edited. See section 4.1.2 for characters.

When tag editing is complete, operate the Enter key, followed by the Cancel key, to re-call the Channel Config page

This completes the Channel Range configuration. We now need to go to Channel Alarm configuration, then Channel Trace.

ALARM TYPE

From the *Channel :Range* page, operate the page key to call the *Channel : Alarm* page.

By default, alarm 1 of the four alarms is already selected, and we will use this for convenience.

Use the Enter key to call the Setpoint page, then again to call the enable page.

Use the up arrow key to scroll through 'Unlatched' to 'Latched'. See section 4.5.2 for a description of different types of alarm.

Use the Page up key to call the alarm type page. By default, 'Absolute Low' appears at the display.

Operate the up arrow key to select 'Absolute High'.

'E'	Damping <u>None</u>	
'E'	Brk Rsp <u>None</u>	
'E'	Brk Rsp Drive Hi	
'E'	Offset _ 0.00	
'E'	Tag: <u>Channel 1</u>	
'E'	Tag: Furnacel temp <u>A</u>	
	Tag: <u>F</u> urnacel tempA	
	Channel : Range	
	Channel : Alarm <u>1</u>	
	Alarm : Setpoint	
	Enable <u>Off</u>	
'E'	Enable <u>Unlatched</u>	
'E'	Enable <u>Latched</u>	
'E'	Type <u>Absolute Low</u>	
'E'	Type <u>Absolute High</u>	

2.5.3 CHANNEL CONFIGURATION (Cont.)

ALARM THRESHOLD (SETPOINT)

Operate the Page up key to call the Threshold page.

Use the up arrow and cursor keys to set the threshold to 780.00, using the technique described for input range (section 2.5.3 above).

In this case the decimal point is in the right place and does not need to be entered.

Operate the Enter key to confirm the setting, then the Cancel key to return to the *Alarm : Setpoint* page.

ALARM JOBS

Use the Page up key to call the Alarm Job 1 page, and operate the Enter key.

Use the up arrow key repeatedly to scroll through the available jobs, until 'Send log 1 to chart' appears, then operate the page key.

Initially, log 1 contains input channels 1 to 6. The contents can be changed in log configuration as described in section 4.6.1.

Page to the actions choice. The 'On going Active' action is as required, and our alarm configuration is now complete,

Operate the Enter key to enter the changes made so far, then operate the Cancel key twice to return to the *Channel : Alarm 1* page.

Use the Page up key to call the *Channel : Trace* page

Type Absolute High	
Threshold _ 0.00	
Threshold 780.00	'E'
Threshold 780.00	
Alarm : Setpoint	
Alarm : Job 1	
No Action	
	'E'
Chart Online	
	'E'
Chart span B Ch 1	
	'E'
Chart Span B for All	
	'E'
Disable all alarms	
	'E'
Ack all alarms	
	'E'
Send log 1 to chart	
	'E'
On going active	
On going active	
Alarm : Job 1	
Channel : Alarm 1	
Channel : Trace	

2.5.3 CHANNEL CONFIGURATION (Cont.)

CHECKING THAT THE TRACE IS ON

Use the Enter key to call the trace on/off page

If the trace is off, use either arrow key to scroll to 'On'.

Use the Enter key to confirm the changes, then the Cancel key repeatedly, until the Operator menus are reached.

Use the page or cancel key repeatedly until the 'Op: display' screen is displayed, then press the Enter key to return to the background display.

Since your input signals will almost certainly be different from those described above, the recorder will display its over or under range display.

To cure this you must re-enter the configuration menus and set all your channels to suit your particular input signals.

If you want to do more than the very basic configuration given above, details are to be found in section 4 of this manual, or in the relevant option sections as appropriate.

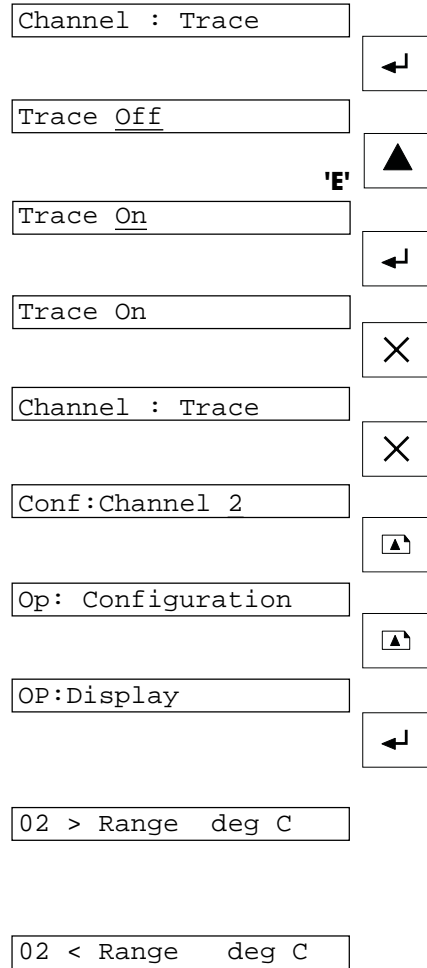

3 OPERATOR MENUS

3.1 INTRODUCTION

This section describes the operator menu structure of the basic recorder. For details of Options such as relays, analog retransmission, derived variables (math), memory card or serial communications; see the relevant option section.

3.2 TOP LEVEL OPERATOR MENUS

As described in section 2, the recorder goes into 'background mode' on power-up, showing the value of a channel or other process variable, as configured. In order to enter the operator menus, the 'Cancel' (X) key is used. This brings the following to the display:

Op:Display

This allows a return to the background display using the enter key or entry to other Operator pages, using the 'Page' keys. The other Top level operator pages (excluding options) are:

Op:Chart

Op:Alarm Summary

Op:Alarm setup

OP>Action

Op:Clock

Op:System error

Op:Configuration

OP:Calibrate chart

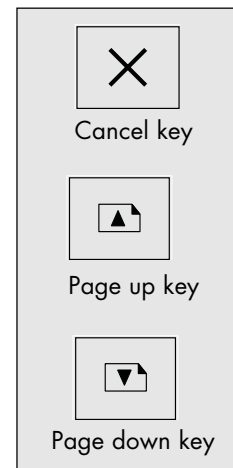

3.3 CHART SUBMENU

This allows the operator to carry out the following functions, unless his access is restricted as described in Section 4.13

1. Switch the chart drive on and off
2. Park the printhead for the replacement of chart or print head
3. Align the chart time.
4. Display current chart speed
5. To initiate logging to chart.
6. To print scales on the chart immediately instead of waiting for their normal cycle time to come round.

3.3 CHART SUBMENU (Cont.)

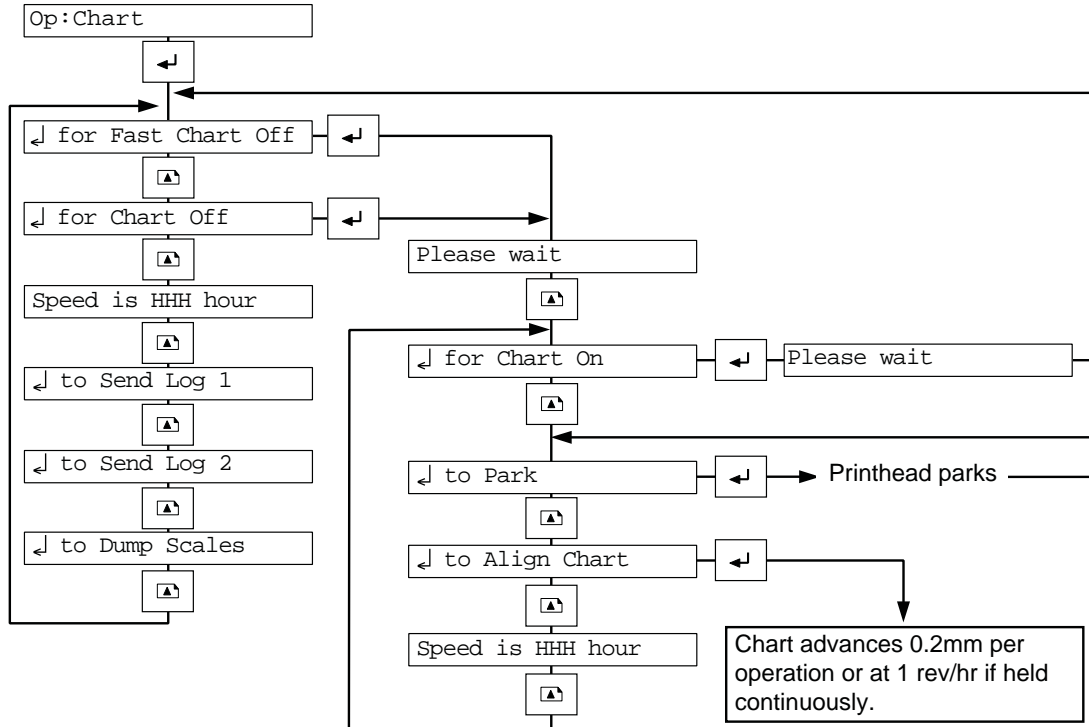

Figure 3.3 Chart Operator Menus

3.3.1 Chart on/off

If access is allowed (section 4.13), the operator can switch the chart drive on and off as required. When the chart is off, the printhead can be 'Parked' for replacement. 'Chart fast off' allows the recorder to complete the current line of printing (if any) before switching chart drive off. 'Chart off' causes the recorder to print any queued messages before switching off.

CHART ALIGN

This function is used to align the pre-printed time marks on the chart with the time reference point of the recorder (see section 1.3). Single operations of the enter key cause the chart to move approx 0.2 mm at its edge. Continuous operation of the key causes the chart to move continuously at 1 rev/hr until the key is released. Chart drive must be off.

3.3.2 Logs

When delivered from the factory, Log groups 1 and 2 contain all the recorder's input channels. During 'Group configuration' (section 4.6) these items can be deleted individually, and if the relevant options are present, derived variables, totalisers and counters can be added. The log format can be set up to include tags or not as required.

OPERATOR INITIATION

The contents of either group can be printed on the chart at any time by the operator from the display page:

↵ to Send Log N

Where N = 1 or 2 - see figure 3.3

JOB INITIATION

The contents of Log 1 group and/or Log 2 group can be sent to chart and/or memory card (if present) using 'jobs' as described in section 4.1.5.

AUTOMATIC LOGGING

Two log intervals (A and B) can be configured in 'Chart configuration' and if this is done, log group 1 will be printed on the chart automatically at log interval A or B, interval B being selected by job action. Setting interval A (B) to 0hr, 0 min, disables the automatic printing of the log at interval A (B).

Two archive intervals (A and B) can be configured in 'Memory card configuration' if the relevant option is present. If this is done, log group 2 will be sent to memory card automatically at archive interval A or B, interval B being selected by job action. Setting interval A (B) to 0hr, 0 min, disables the automatic archiving of the log at interval A (B). Logs are printed in black with values in alarm shown in red.

3.3.3 Scale print (Dump Scales)

Operating the 'Enter' key from this page causes the recorder to print all channels' scales on the chart as quickly as it can.

↵ to Dump Scales

3.4 ALARM SUMMARY PAGE

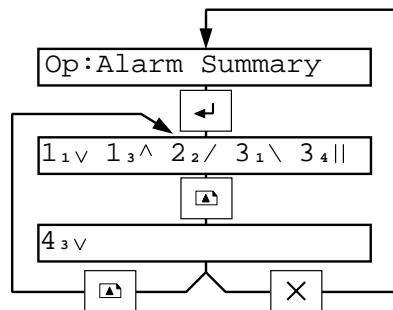

For more details of alarm types and actions see section 4.5.2

For a description of the alarm display; see next page.

Figure 3.4 Alarm summary page

This Operator page allows the status of all current alarms to be viewed.

3.4.1 Display interpretation

The alarms appear in channel order, and are flashing if not acknowledged. Each alarm is presented as a channel number (full size), followed by a subscript alarm number (1 to 4) .

3.5 ALARM SETUP PAGE

This page allows the operator to view the alarm type, threshold settings etc.

If access is allowed (Section 4.13) the operator may adjust the threshold settings.

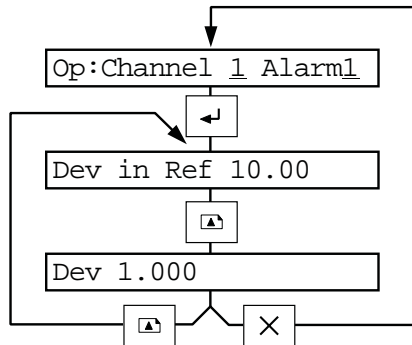

Use up/down arrows and cursor to select channel number and alarm number.

View alarm type:
Abs high/low, ROC rise/fall or Deviation in/out.
Edit setpoint if necessary using arrow up/down keys.

Deviation value for Deviation alarms
Period for Rate-of-Change alarms

Figure 3.5 Alarm setup page

3.6 ACTION

This page allows the 'Enter' key to be used as an event trigger (Section 4.10). The label which appears, and the defining of the action to be carried out as latching or not latching is set up in the Operator Action part of configuration (Section 4.7).

As despatched from the factory, the label is 'Ack All', it is non-latching and its jobs list is to acknowledge all alarms

3.7 CLOCK

This page allows the user to view the current system time and date.

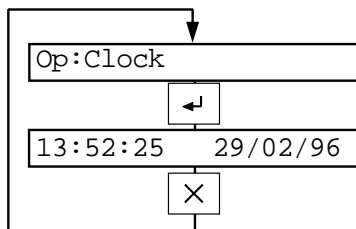

Date format (DD/MM/YY or MM/DD/YY) set up in Clock configuration (Section 4.8.2)

Figure 3.7 Operator clock display page

3.7.1 Back-up battery

The system date and time are maintained under power-off conditions, by a re-chargeable Nickel-metal hydride battery. When fully charged, the battery will maintain the time and date for approximately one month.

As despatched from the factory, the battery is discharged. A fully charged battery will provide backup protection for a minimum of one month at a maximum temperature of 40°C. A discharged battery, charged for one hour, will provide a minimum of 48 hours of backup protection at a maximum of 40°C.

Note: The battery on the main circuit board is not a user replaceable item. If the battery does not function, consult factory for service information.

3.8 SYSTEM ERROR

This page allows the user to view any system errors which have occurred. If the relevant options are fitted, the following errors can be reported. If more than one is active, the Page key is used to scroll through the list:

- Bad Remote CJ Temp
- Writing system fail
- Disk overdrive (archiving buffer full with no disk present or no more disk space available).
- Battery Failure
- Clock failure
- EEPROM DB Cleared
- Battery-backed RAM cleared
- Memory Card Battery Low
- Memory Card Battery Flat
- DV Run Time Error

3.9 CONFIGURATION

Operation of the Enter key from this page followed by a password, allows the user access to the configuration pages described in Section 4.

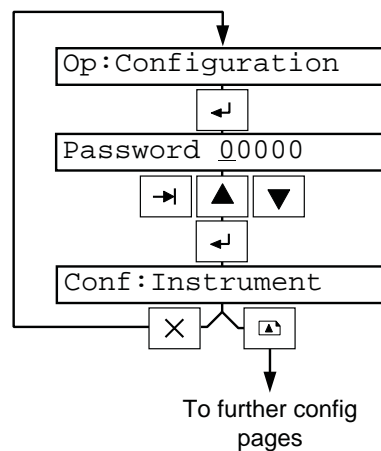

The password set to 00010 by manufacturer, but it can be edited in Instrument Configuration.

If set to 00000, Configuration pages are entered directly without having to enter a password.

Figure 3.9 Entry to configuration

3.10 CALIBRATE CHART

This page allows the printhead zero and span positions to be set to chart zero and span. On initiation, the printhead traces lines on the chart where it thinks zero and span are. If incorrect, the positions can be adjusted using the up arrow key to move the trace slightly to the right, or the down arrow key to move it to the left.

Note: Zero (center of chart) setting should always be carried out before the span (outer edge of chart) setting. The chart must be turned OFF to access this function.

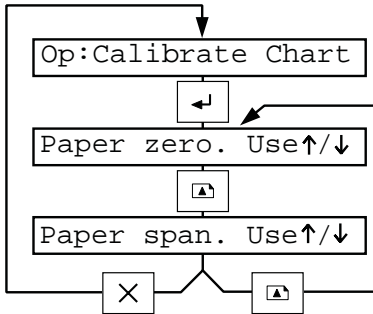

Figure 3.10a Chart calibration pages

Use up/down keys to adjust trace position
(Effects shown much exaggerated for clarity)

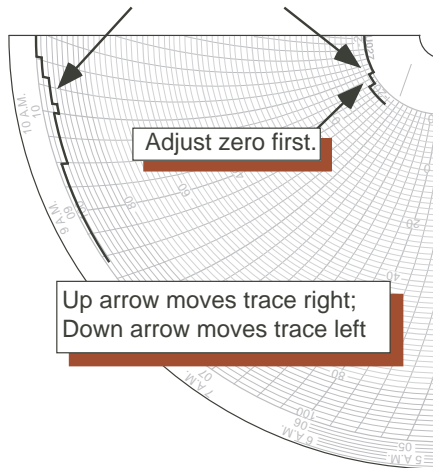

Figure 3.10b Zero and Span adjustments (simulated chart sample)

3.11 OPERATOR MENU SUMMARY

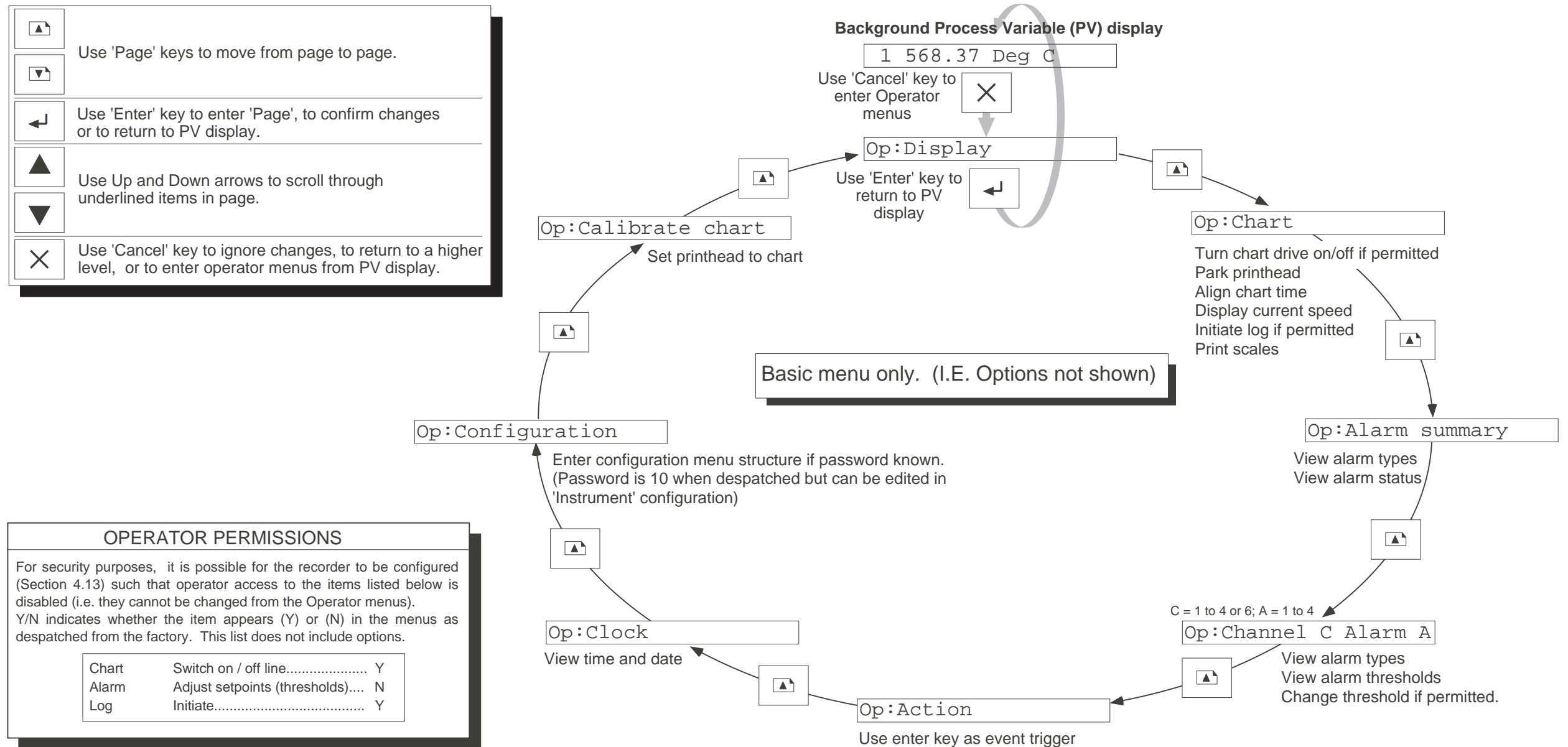

Figure 3.11 Top level Operator Menu structure

This page is deliberately left blank

4 CONFIGURATION

Note: In order to help new users, a brief configuration guide appears as section 2 of this manual. This guide gives step-by-step instructions to show an example configuration of a single input channel.

Note: A configuration tool, to run on a PC, is available from the manufacturer to speed configuration and text entry.

4.1 INTRODUCTION

The configuration of the basic recorder is divided into the following categories. Options are described in later sections.

1 Instrument	6 Clock
2 Chart	7 Messages
3 Channel	8 Alarm Messages
4 Group	9 Events
5 Operator action	10 Configuration Transfer

In addition to the above, Diagnostics and Operator Access are included in the configuration menus.

The above categories are listed in the order in which they appear when the page key is being used, but it is not necessary to carry out the configuration in that order. In order to help you find your way around the table 4.1 overleaf relates 'what you can do' with 'where you do it' and where in the manual you can find details of it for basic recorder functions (i.e. options are not included).

4.1.1 Password

In order to prevent unauthorised access to the recorder's configuration, a password protection system operates. When despatched from the factory, this password is set to 00010, but this can be modified as a part of the [Instrument configuration](#) described in section 4.3

Setting the password to a 00000 subsequently allows direct access from the operator menu without further need for a password.

4.1.2 Text entry

A number of items (messages, tags, units strings etc.) require text to be entered or modified. Text entry is achieved by using the 'Cursor' key to move the underline to the character to be edited, and then using the up and down arrow keys to scroll through the character set until the required letter, number or symbol appears. This process is repeated for all the characters in the text string.

CHARACTER SET

The characters available are:

A to Z, a to z, Ä ä à ç ê ë é Ö ö ô Û ü ù ß Σ μ Ω δ²³ ! “ • [\] ^ * { | } ~ Ç â å ä ë ì î ï Å É æ Æ ò û ý ç ¥ á í ó ú ñ Ñ ù ò ì ; « » α Γ π σ τ φ θ ∞ ∈ ∩ ≡ # \$ % & () * + , - . / : ; < = > _ £ ° 0 to 9 (Space)

4.1 INTRODUCTION (Cont.)

Parameter etc. to be edited	Configuration page name	Where to look
Adaptive recording	Chart	Section 4.4.5
Adjust input	Adjust	Section 4.14
Alarm Jobs	Channel: Alarm: Jobs	Section 4.5.2
Alarm Parameters	Channel : Alarm : Setpoint	Section 4.5.2
Break response	Channel : Range	Section 4.5.1
CJC (remote) channel	Instrument	Sections 4.3.3, 4.3.4
CJC type selection	Channel : Range	Section 4.5.1
Channel colour	Channel : Trace	Section 4.5.3
Channel parameters	Channel: Range	Section 4.5.1
Channel scroll list	Group	Section 4.6
Channel span	Channel : Trace	Section 4.5.3
Channel trace on/off	Channel : Trace	Section 4.5.3
Channels displayed	Group	Section 4.6
Chart speed	Chart	Sections 4.4.1
Clock setting	Clock	Section 4.8
Configuration read/write	Transfer	Section 4.11
Damping	Channel : Range	Section 4.5.1
Date setting/format	Clock	Section 4.8
Date embedding in messages	Message	Section 4.9.1
Decimal point position	Channel : Range	Section 4.5.1
Diagnostics	Diagnostics	Section 4.12
Displayed channels	Group	Section 4.6
Dwell period	Channel : Alarm: Setpoint	Section 4.5.2
Event sources / jobs	Events	Section 4.10
External CJ temp	Channel: Range	Section 4.5.1
Hysteresis	Channel : Alarm: Setpoint	Section 4.5.2
Input adjust	Adjust	Section 4.14
Input range	Channel : Range	Section 4.5.1
Input scaling	Channel : Range	Section 4.5.1
Input type	Channel : Range	Section 4.5.1
Instrument tag	Instrument	Section 4.3.5
Language	Instrument	Section 4.3.2
Line thickening	Channel : Trace	Section 4.5.3
Linearisation type	Channel : Range	Section 4.5.1
Log contents	Group	Section 4.6
Log interval	Chart	Section 4.4.3
Messages	Messages	Sections 4.4.4, 4.9
Operator action key	Operator action	Sections 3.6, 4.7, 4.10
Operator permissions	Access	Sections 4.12
Password	Instrument	Sections 3.9, 4.1.1, 4.3.1
Pen zero/span setting	Calibrate chart	Section 3.10
Printing on the chart	Chart	Section 4.4.4
Process value in messages	Message	Section 4.9.1
Reference (deviation alarms)	Channel : Alarm : Setpoint	Section 4.5.2
Remote CJ	Instrument	Sections 4.3.3, 4.3.4
Restore configuration	Transfer	Sections 1.2.2, 4.11
Save configuration	Transfer	Sections 1.2.2, 4.11
Shunt Value	Channel : Range	Section 4.5.1
Tag	Channel : Range	Section 4.5.1
Text entry/embedding	Various	Sections 4.1.2, 4.9.1
Time embedding in messages	Message	Section 4.9.1
Time set	Clock	Section 4.8
Value format	Channel : Range	Section 4.5.1

Table 4.1 Configuration parameter locator

4.1.3 Options

Option descriptions appear in later sections of this manual.

4.1.4 Logs 1 and 2

Logs are alphanumeric reports showing the current values of a number of process variables. Logs can either be printed on the chart, or if the appropriate (archiving) memory card option is fitted, they can be sent to memory card-. As despatched from the factory, the two log groups contain input channels 1 to 6. To include option PVs such as totalisers, derived channels etc., the user can edit the log groups as described in Group configuration (section 4.6.1). Group configuration also allows the group format to be defined, i.e. whether Process variable (PV) tags and instrument tag are to be included.

Logs can be initiated in the following ways:

- a. Automatically at fixed time periods (section 3.3.3)
- b. From the Operator menu (section 3.3.3)
- c. By job action - (section 4.1.5)

Note: When logging automatically:

Log 1 prints contents on the chart at one of two logging intervals (A or B) set up in Chart configuration (section 4.4.3). Normally, interval A is used; interval B is selected by job action (section 4.1.5).

If a memory card archive option is fitted, Log 2 saves its group contents to the memory card at one of two archive intervals (A or B) set up in the Memory Card configuration (described in section 12). Normally, archive interval A is used; interval B is selected by job action (section 4.1.5).

4.1.5 Jobs

Jobs cause the operation of the recorder to change as the result of an initiating trigger which can be an alarm going active, an event input, a totaliser reaching a previously specified value and so on. A list of job actions and 'modifiers' is given in figure 4.1.5 following.

A modifier defines when the relevant action is to occur (e.g. While active, While inactive).

4.1.5 JOBS (Cont.)

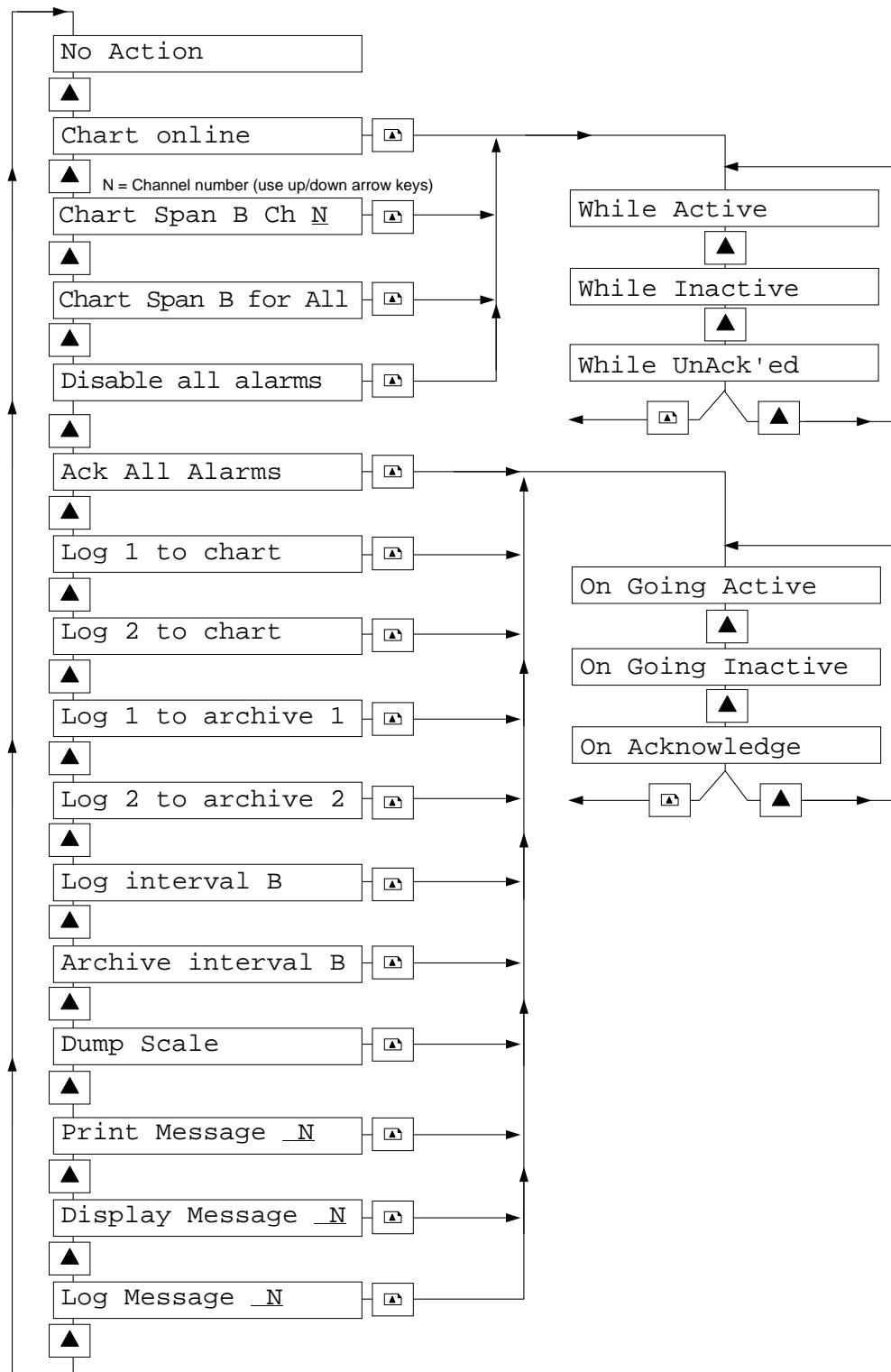

Figure 4.1.5 Jobs and modifiers

4.2 CONFIGURATION TECHNIQUES

Configuration menus are treated in the same way as operator menus, with the page and enter keys being used to select a parameter, and the arrow keys being used to edit it. To return to a higher menu level the cancel (x) key is used. Figure 4.2 below shows the alarm setpoint sub-menus in an attempt to illustrate these techniques.

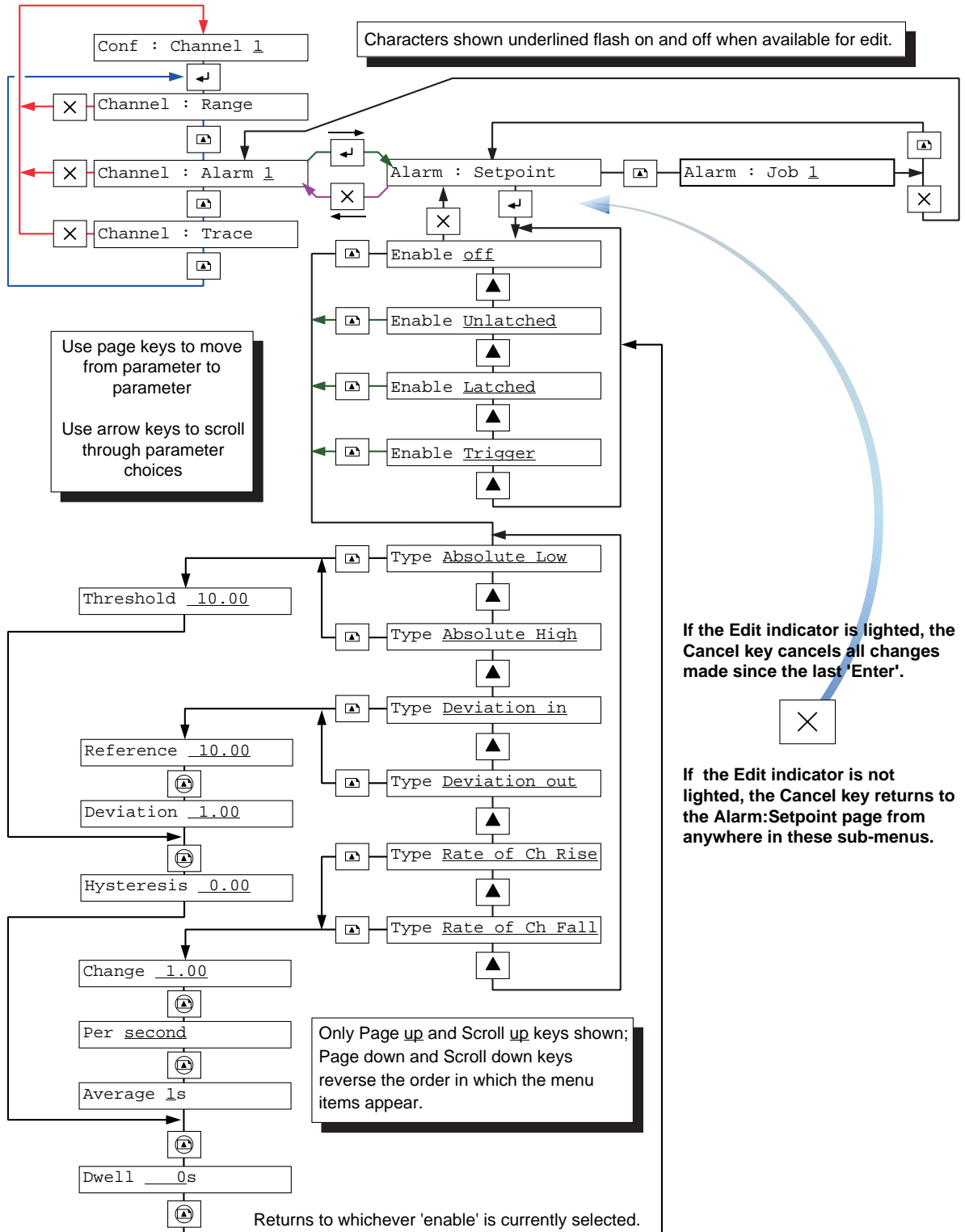

Figure 4.2 Configuration techniques

4.3 INSTRUMENT CONFIGURATION

Instrument configuration allows:

1. The setting of a new password
2. The setting of a different language for subsequent displays and chart printing
3. Configuration of remote cold junction input

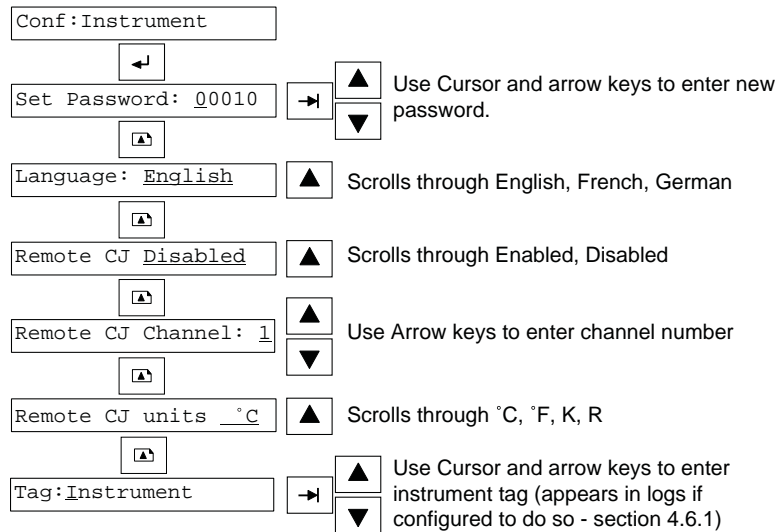

Figure 4.3 Instrument Configuration pages

4.3.1 Password

The password can be any five-character (max.) string, entered using the cursor and arrow keys as described in [section 4.1.2](#). You can set the password to 00000 to disable password protection, thus allowing access to the configuration menus without further need of a password.

4.3.2 Language

English, French or German can be selected as the language for subsequent operations.

4.3.3 Remote CJ Channel

When 'Enabled', any input channel can be selected for use as a remote cold junction measuring channel. In such a case, the selected input type, range, linearisation etc. must be set up in the channel configuration ([section 4.5](#)) for the selected channel. The temperature units set up in the channel's configuration must match those set up in 'Remote CJ Units' described immediately below.

Once a remote CJ channel has been configured, any other input channel can use it as a 'Remote' CJ input, if so configured.

4.3.4 Remote CJ units

Scrollable through °C, °F, Kelvins or Rankine, the remote CJ units must match the units configured for the Remote CJ channel.

4.3.5 Instrument tag

A 16-character max. descriptive tag can be entered. See [section 4.1.2](#) for text entry techniques.

4.4 CHART CONFIGURATION

Chart configuration allows the following to be set up:

1. Chart speed.
2. Log interval for logging Log 1 Process Variables automatically on the chart.
3. Time/date/scale/chart speed etc. data.
4. Adaptive recording on/off.

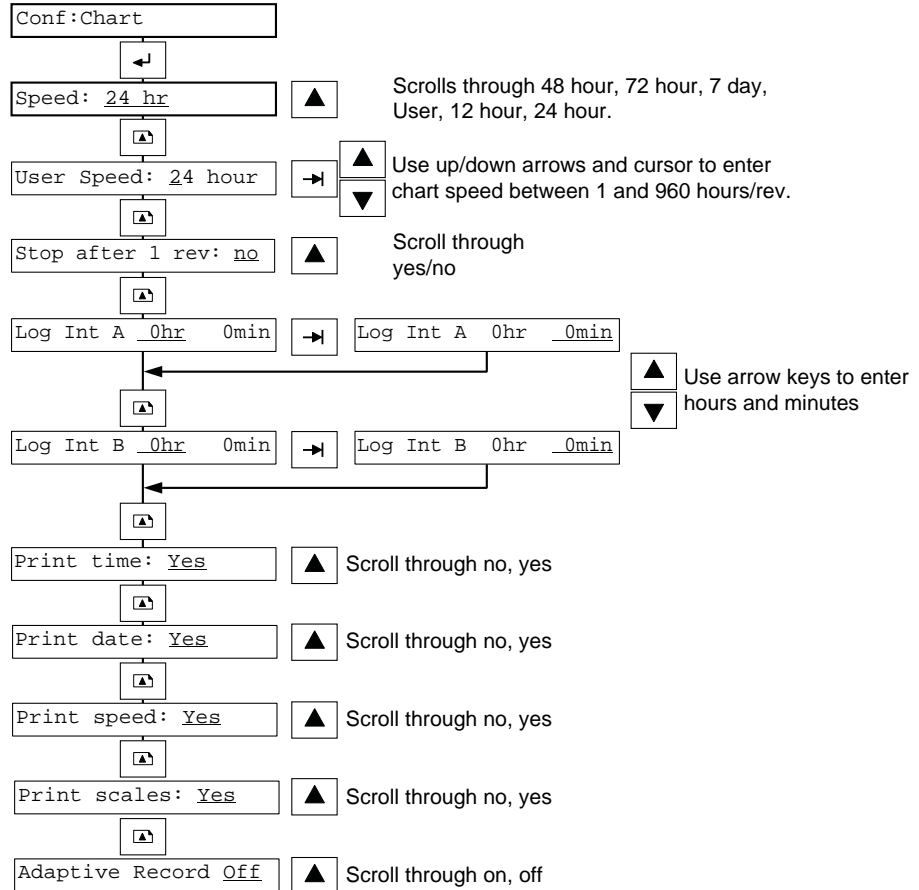

Figure 4.4 Chart configuration pages

4.4.1 Chart speed

Standard chart speeds of 1 revolution per: 12 hours, 24 hours, 48 hours, 72 hours, 7-days or 'User' can be selected. If 'User' is selected, the recorder will use the speed entered on the following page.

4.4.2 User chart speed

A number of hours per revolution, from 1 to 960, can be entered here. This speed is used if 'User' is selected in the Chart speed page described above. All annotation stops (tracing continues) at chart speeds faster than 6 hr/rev.

4.4.3 Stop After One Revolution

When selected, this feature causes the chart to complete one turn from the point at which it was last placed online and then stop. The tracing will stop, the "Chart online" event source will become inactive and any demand annotation will print at maximum speed.

4.4.4 Log intervals A and B

Two log intervals can be entered here for the automatic periodic printing of log group 1 on the chart. The cursor key is used to move from 'hr' to 'min' fields, and the up/down arrow keys to enter the required value. An entry of 0 hours, 0 minutes stops automatic logging to chart at that interval (i.e. A or B). For log content and format, see Group configuration - [section 4.6](#)

Log interval A is used under normal conditions. Interval B can be selected only through job action ([section 4.1.5](#))

4.4.5 Printing

TIME/DATE/CHART SPEED

If individually selected 'yes', time, date, and chart speed can be printed on the chart at chart on-line.

SCALE

If selected 'Yes' low and high end scale values will be printed at regular intervals on the chart.

MESSAGES

Twenty user messages of 20 characters each can also be printed as a result of job action.

4.4.6 Adaptive recording

At slow chart speeds, it is possible that a spike or other brief disturbance in the measured signal will be picked up by the input circuit between chart increments, and they will thus not appear on the chart (even though they might trigger an alarm). With adaptive recording enabled; if a sudden change in the input signal is detected, the recorder will put an extra dot on the chart without the chart being moved. This means that even at the slowest chart speeds, fast signals can still be traced on the chart.

When adaptive recording is enabled, it applies to all channels.

4.5 CHANNEL CONFIGURATION

Channel configuration is in three parts: Range, Alarms and Trace.

4.5.1 Range configuration

This sub section allows the setting up of the following:

1. Input type, range and units
2. Linearisation type
3. Scaling
4. Value format (decimal point position)
5. Input damping
6. Input break response
7. Channel tag (identifier or descriptor)
8. CJ type for thermocouple inputs
9. Shunt value for mA inputs
10. Open/Closed text strings for digital inputs

Figure 4.5.1 shows the configuration menu for Input Type = volts (from a 4-20 mA input using a 250 Ω shunt. Other input types are similar, and any parameters unique to a particular input type are indicated in the accompanying descriptions.

INPUT TYPE

Allows an input type of Thermocouple (T/C), mV, V, mA, Resistance Temperature Detector (RTD), Ohms, Digital input, Comms (if communications fitted), Cont 1/2 (if controller(s) fitted) or 'Test' to be selected. The appearance of some subsequent display pages is dependent on this selection.

NOTE: To ensure best accuracy, ALWAYS use mA input type with current input through a shunt resistor.

INPUT RANGE

The low and high settings should match the lowest and highest values which the recorder will have applied to its inputs. This allows the recorder to select the best (i.e. most accurate) electronic range for your input. The up arrow and cursor keys are used to enter the value (including the decimal point).

These pages do not appear for Digital or Comms (if fitted) inputs, or if the selected Input Type is 'Test'.

SHUNT VALUE

For mA input type only, allows a shunt value to be entered (normally 100 or 250 Ω). The entered value must match that of the fitted shunt. Best accuracy can be achieved by using a current loop shunt of 50 Ω or less (1.0 Volts at 20 mA). See specification section (Annex A) for accuracy information.

INPUT UNITS

This page appears only for thermocouple and RTD inputs and allows $^{\circ}\text{C}$, $^{\circ}\text{F}$, K(elvins) or R(ankine) to be selected.

4.5.1 RANGE CONFIGURATION (Cont.)

LINEARISATION TYPE

The linearisation types (if any) which appear on the scroll list depend on the Input Type selected. The complete list is:
 Linear, square root, $x^{3/2}$, $x^{5/2}$,
 Thermocouple types B, C, D, E, G2, J, K, L, N, R, S, T, U, Ni/NiMo, MoRe, Platinel,
 RTD types Pt₁₀₀, Pt₁₀₀₀, Ni₁₀₀, JPt₁₀₀, Pt₁₀₀A, Cu₁₀

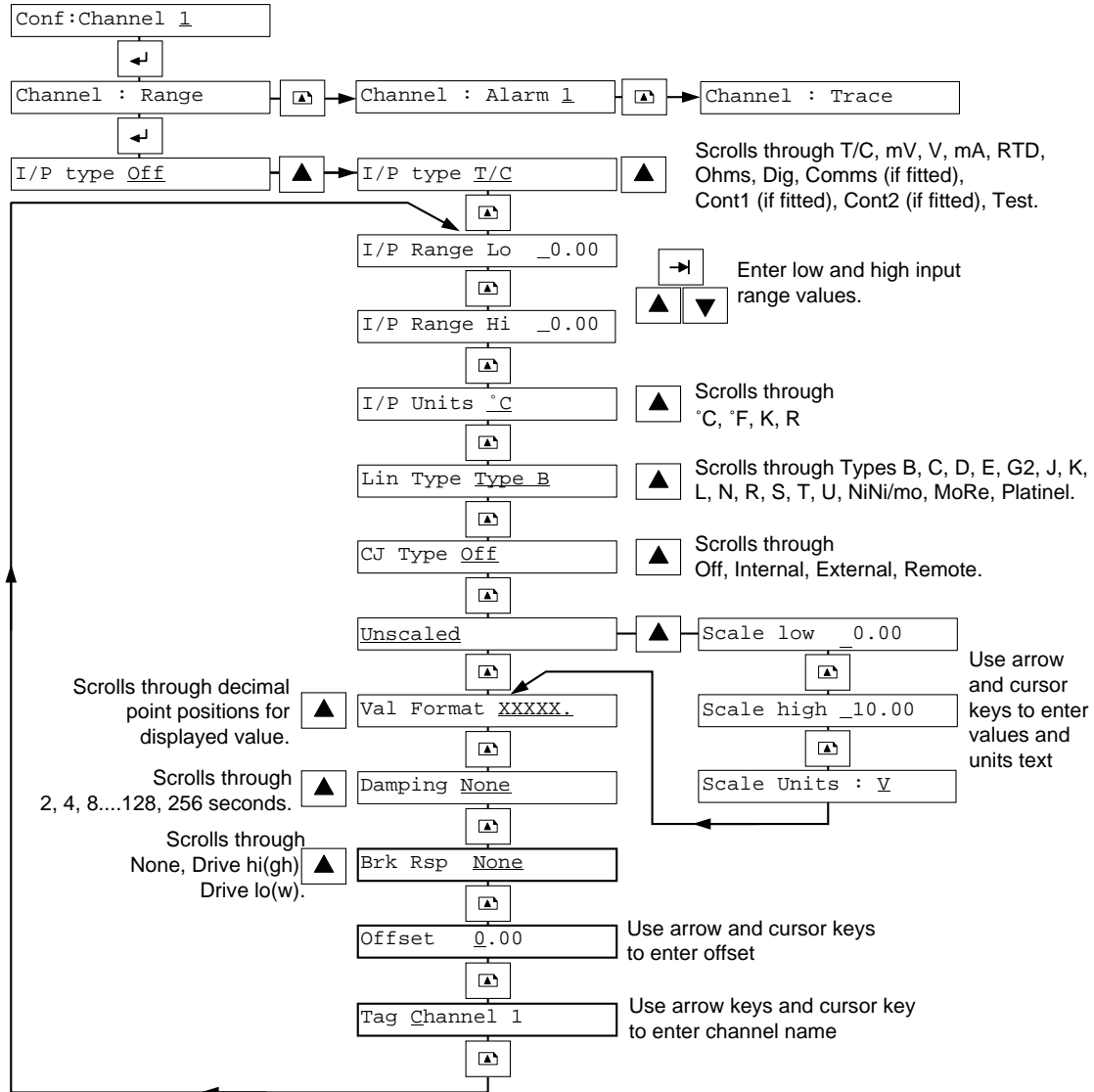

Figure 4.5.1 Channel configuration pages for thermocouple inputs

4.5.1 RANGE CONFIGURATION (Cont.)

CJC TYPE

For thermocouple inputs only, allows Off, Internal, External or Remote to be selected as cold junction type.

Internal uses the recorder's internal temperature sensor to apply cold junction compensation.

External is used where the cold junction of one or more thermocouples is maintained at a known temperature. When 'External' is chosen as CJC type, operation of the Page key calls a further page where the known temperature is to be entered.

Remote uses a temperature sensor connected to a separate input channel to measure the cold junction temperature of one or more remote thermocouples. This allows copper cable to be used from the remote location to the recorder, instead of high cost compensation cable. The input channel for the CJ temperature measurement is defined in 'Instrument' configuration (Section 4.3.4).

SCALED

This allows the input to be scaled (e.g. 4 to 20 mA input = 0 to 100%). The scaling low and high values are entered using the cursor and up arrow keys as for input values. The Scale units are entered using the text entry technique described in section 4.1.2, above.

VALUE FORMAT

Allows the decimal point position to be chosen for the process value. The up/down arrow keys are used to move the decimal point from XXXXX. to X.XXXXX (when set to X.XXXXX, the decimal point will "float" to the right as the number increases).

DAMPING

For 'noisy' slowly changing signals, damping can be used to filter noise so that the underlying trend can be seen more clearly. The arrow keys allow selection of 2, 4, 8, 16, 32, 64, 128 or 256 seconds.

It is not recommended that damping be used on quickly changing signals.

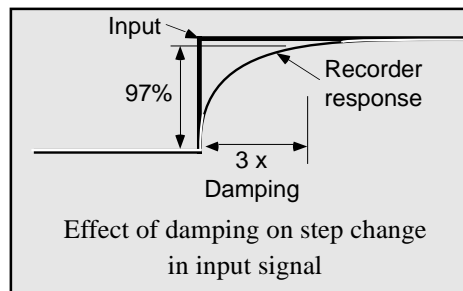

BREAK RESPONSE

For lower ranges only (i.e. thermocouples and voltages less than 150 mV) the recorder can be made to respond in a known way if a break in the input circuit is detected.

Note:- The break response for ALL CHANNELS on any single recorder must be selected as either: (upscale or none) OR (downscale or none). Upscale and downscale CANNOT BE MIXED on a recorder

Break response can be set to

- None (trace drifts with input wiring acting as an aerial)
- Drive hi (trace is placed at the outside edge of the chart)
- Drive lo (trace is placed at the inside edge of chart)

4.5.1 RANGE CONFIGURATION (Cont.)

OPEN / CLOSED

For Input Type digital (not available on Channel 1), the PV display consists of a text string or an open/closed representation. The strings which are to appear under open (logic low) and closed (logic high) conditions can be scrolled through using the up/down arrow keys.

These text strings are: Open, Close, ___ - ___, _____, In, Out, Hi, Lo.

TEST WAVEFORMS

When Input Type is selected as 'Test', the following four test waveforms can be selected and scaled both for tracing on the chart and for the displayed value:

Triangle - 5 hrs or 40 mins

Sine - 5 hrs or 40 mins

TAG

This allows a 14-character descriptive name (tag) to be associated with each channel. This tag is used both for display and for logging. See [section 4.1.2](#) for text entry techniques.

4.5.2 Alarm configuration

Up to four alarms can be configured for each channel. For absolute and deviation alarms, a hysteresis value can be entered to prevent spurious triggering should the process value 'hover' around the alarm threshold. For all types of alarm, a dwell (or waiting) period can be configured, and if the alarm clears within this period, the alarm is ignored. Each alarm can initiate up to two jobs, as described in [section 4.1.5](#) above.

SETPOINT CONFIGURATION

Allows you to set up alarm type, threshold value, hysteresis etc. Figure 4.5.2a shows display pages for absolute alarms. For deviation and rate-of-change alarms, some of the display pages will be different from those shown.

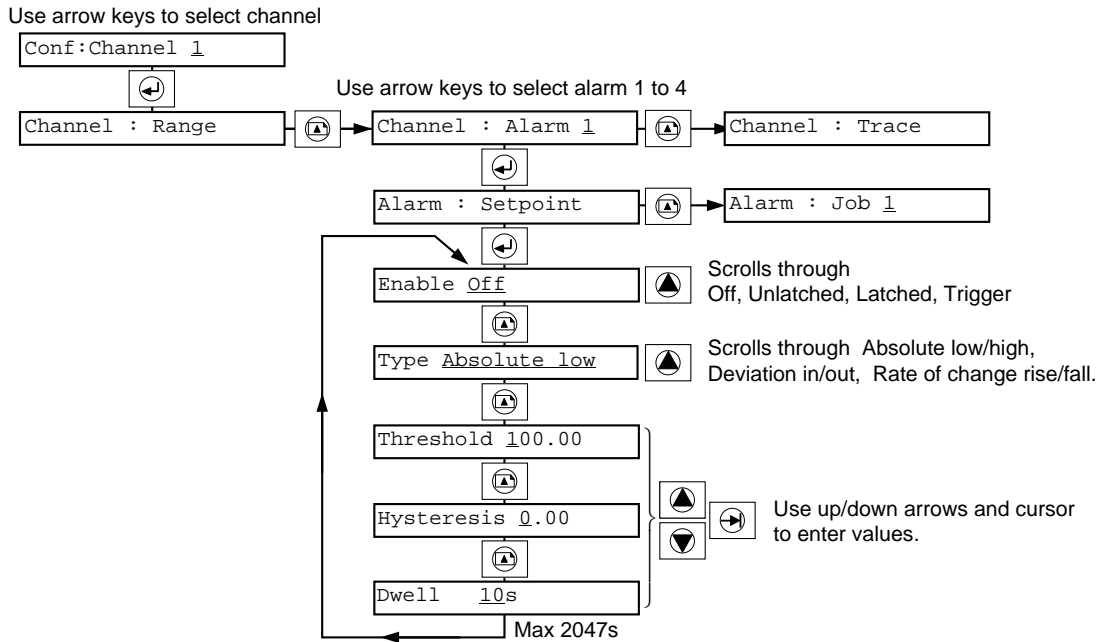

Figure 4.5.2a Alarm configuration pages: Absolute alarms.

ENABLE

Off, Unlatched, latched or trigger can be selected for the alarm, using the up or down arrow key.

Off	The alarm is disabled
Unlatched	When triggered, the alarm stays active until the triggering source returns to a non-alarm state. Alarm indicators flash until acknowledged, then stay permanently on until the alarm is no longer active. Alarm messages can be printed on the chart if alarm jobs trigger Customer Messages.
Latched	When triggered, the alarm stays active until it has been acknowledged and the triggering source returns to a non-alarm state. Alarm indicators flash until acknowledged, then stay permanently on until the alarm is no longer active. Alarm messages are printed on the chart. Continuous jobs remain active only until the source has returned to a non-alarm state (whether or not the alarm has been acknowledged). NOTE - relay action does not latch when alarm is no longer active.
Trigger	When triggered, any jobs associated with the alarm are initiated, and for continuous jobs (e.g. change chart speed) continue until the triggering source returns to a non-alarm state. Trigger alarms are not annunciated.

4.5.2 ALARM CONFIGURATION (Cont.)

For clarity, the following alarm diagrams are shown with straight rather than curved value lines. PV values increase from the right (inner) to left (outer) portion of the chart.

ALARM TYPES

Absolute alarms

An absolute high alarm becomes active when the PV value rises above the alarm threshold value. The alarm remains active until the measured value falls below (*setpoint - hysteresis*).

An absolute low alarm becomes active when the PV value falls below the alarm threshold value. The alarm remains active until the measured value rises above (*setpoint + hysteresis*)

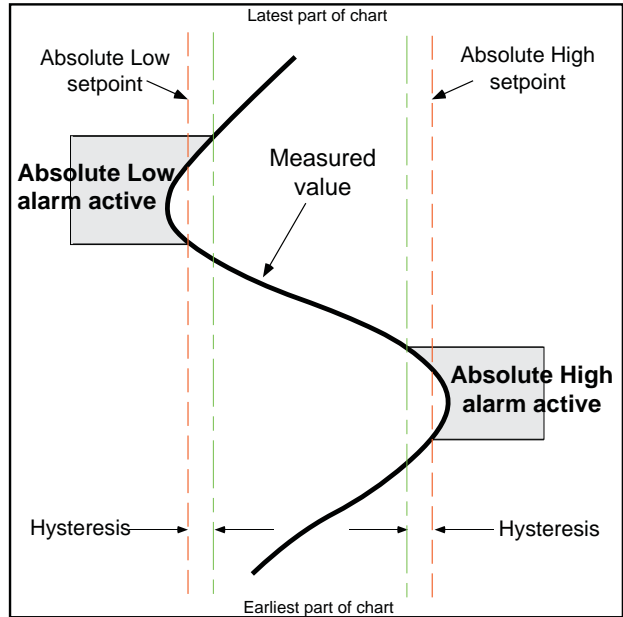

Figure 4.5.2b Absolute alarm definition

Deviation alarms require a reference value and deviation value and can have a hysteresis value entered if required. 'Deviation out' alarms are active

- a. when the PV value rises above (*Reference + Deviation*), and remains above $\{(Reference + deviation) - hysteresis\}$, or
- b. when the PV value falls below (*Reference - Deviation*) and remains active until the PV value rises above. (*Reference - Deviation*) + *Hysteresis*.

'Deviation in' alarms are the inverse of the above, as shown in the sketch below.

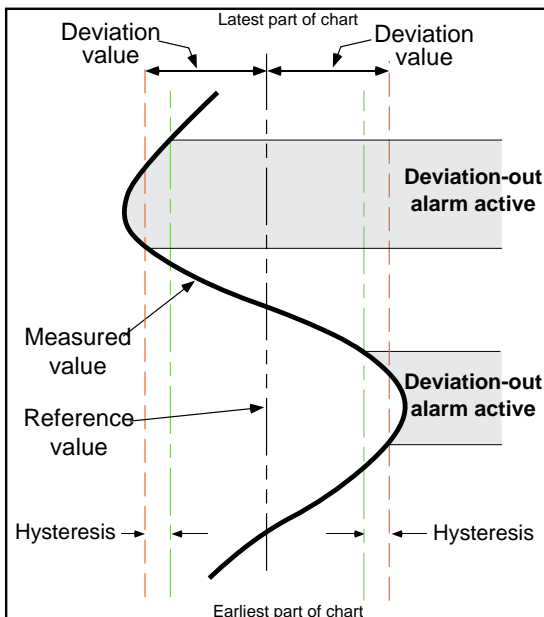

Figure 4.5.2c 'Deviation out' alarm definition

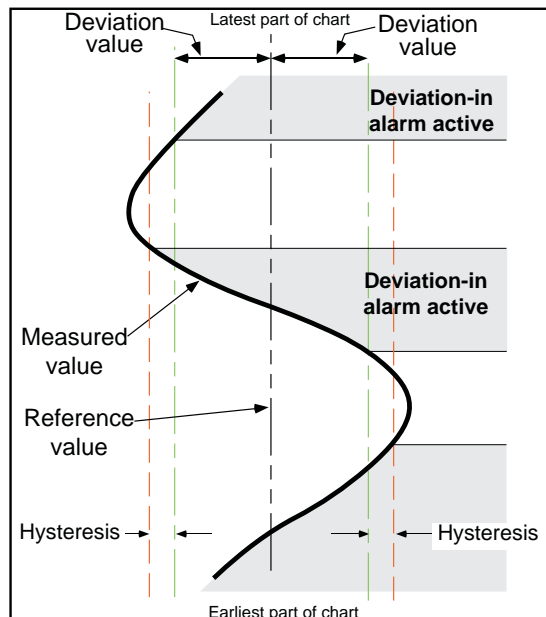

Figure 4.5.2d 'Deviation in' alarm definition

4.5.2 ALARM CONFIGURATION (Cont.)

Rate-of-change alarms

With rate-of-change alarms, a value, a time period and an averaging period have to be configured. In the accompanying sketch, the Value is 200 litres and the Time Period is one minute.

The alarm is triggered if the PV changes by more than the configured Value in less than the configured Time Period (i.e. more than 200 litres/minute in the sketch)

The averaging period can be used to change the sensitivity of the alarm, such that noise spikes or normal oscillations in the input signal do not trigger false alarms.

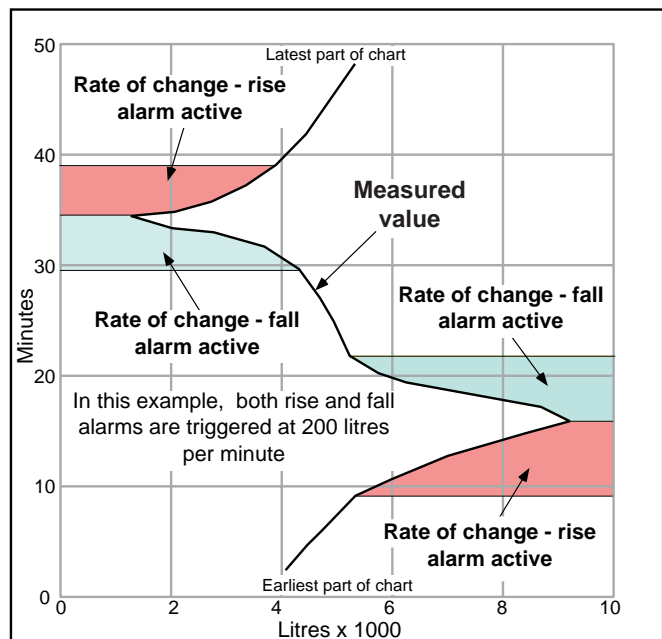

Figure 4.5.2e Rate-of-change alarm definitions

ALARM PARAMETERS

THRESHOLD

Sometimes called 'setpoint', this is the trip point for absolute alarms, entered using the up and down arrow keys.

REFERENCE

For Deviation alarms, this sets a 'central' value on each side of which the Deviation Value (see immediately below) is to operate. The value is entered using the up and down arrow keys.

DEVIATION

For Deviation alarms only, this is a value each side of the reference value, within which a Deviation IN alarm is active, and outside which a Deviation OUT alarm is active. See [figures 4.5.2c and 4.5.2d](#).

CHANGE

For Rate-of-Change alarms only, this allows a value (D) to be entered using the up/down arrow keys. If the change in the channel value (ΔPV) over the specified time period T (see below) is greater than D ($\Delta PV/T > D$) then the alarm is tripped.

PER

For Rate-of-Change alarms, allows a time period to be selected for the above change value. The up arrow key allows 1 second, 1 minute or 1 hour to be selected as the period.

AVERAGE

Allows a period of 0 to 9 seconds to be entered for Rate-of-Change alarms. This has the effect of preventing spurious alarms being triggered by transient changes in the PV value.

HYSTERESIS

Allows a 'deadband' to be entered for absolute and deviation alarms, to prevent alarms being continuously triggered if the process variable value hovers around the trip point. The value is entered using the up/down arrow keys.

DWELL

This feature allows the triggering of any alarm to be delayed for a period configurable up to 2047 seconds. If the alarm source returns to a non-alarm state during the Dwell period, the alarm is ignored. The dwell period is entered using the up/down arrow keys.

ALARM JOBS

As shown in [figure 4.5.2a](#), the jobs page is reached by operating the page key from the Alarm : Setpoint page. Two jobs can be set up for each alarm, and the actions they can carry out are as shown in the [Jobs description](#) in section 4.1.5

4.5.3 Trace configuration

This section of configuration allows you to:

- a. Set Trace on-off
- b. Select trace colour
- c. Set line thickening on/off
- d. Set chart spans A and B for the channel

Figure 4.5.3 on the next page shows typical Channel Trace pages.

Trace

Scrollable through Off and On.

Colour

The following colours can be selected: blue, red, green, black, blue/red and green/black . For single colour traces, the channels' scales are printed on the chart in the same colour as the trace. For bi-colour traces, the traces swap colour every 6 mm (approx.) and the scales are printed in blue for blue/red traces and green for green/black traces.

Line thickening

With line thickening enabled, an extra-wide trace (3 x standard width) is produced to aid long-distance viewing. If line thickening is used for protracted periods, a reduction in the life of the pen can be expected.

Span A / Span B

This allows two spans (A and B) to be selected for the chart trace so that a certain part of the trace can be magnified under certain circumstances (e.g. when the channel goes into alarm).

For example you may wish to record a process warming up from say 20°C to its operating temperature of 700°C, and then to look more carefully at any small variations. In order to do this for channel 1, Span A could be set to 0 to 900°C and span B to 600 to 800°C. An alarm could then be set up as a trigger (to avoid alarm light coming on) at say, 600°C with an associated job: 'Span B for 1' 'while active'.

If Span A/Span B are left 'Unspanned', the input scale range will be used for chart span.

4.5.3 TRACE CONFIGURATION (Cont.)

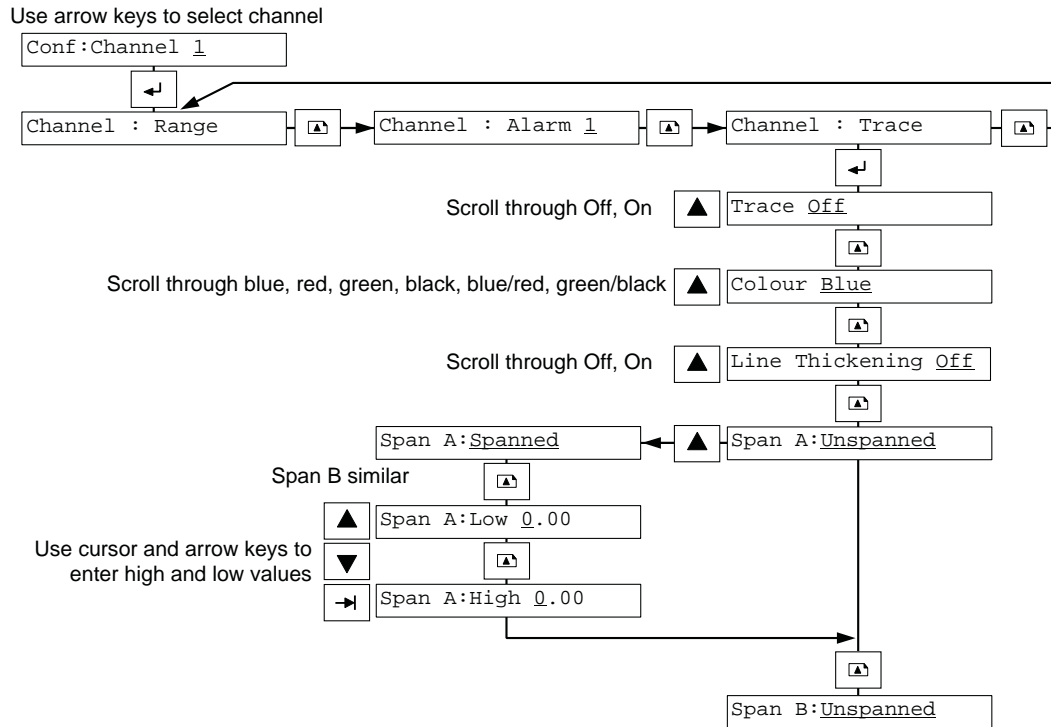

Figure 4.5.3 Channel Trace pages.

4.6 GROUP CONFIGURATION

This allows contents and format of four* groups to be set up: Log1, Log2, DV*, and display.

* Note: DV appears only if the maths option is fitted.

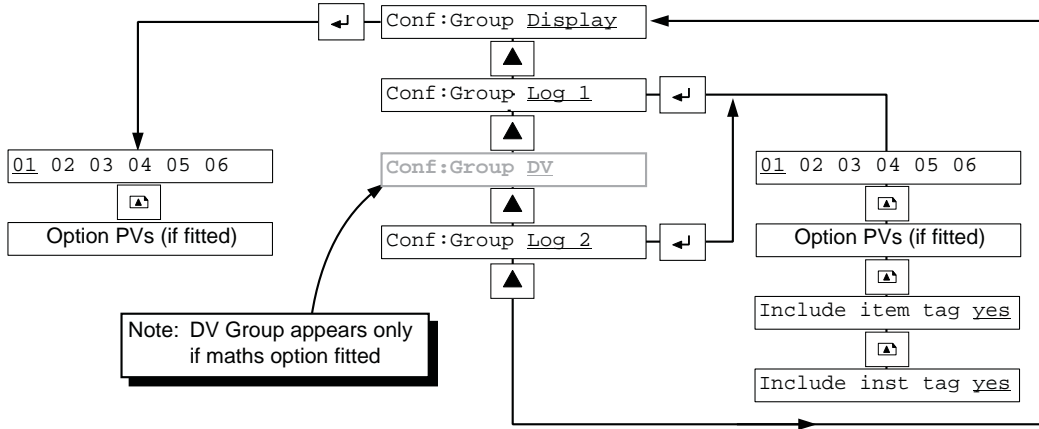

Figure 4.6 Group Configuration pages

4.6.1 Log groups 1,2

Two log groups are available for sending tabular data to the chart, or to memory card (if fitted). Both log groups can be printed on the chart by operator action (section 3.3.3) or by job action (section 4.1.5). Log group 1 can be sent to chart and log group 2 can be sent to the memory card (if fitted) automatically, at fixed intervals as described below.

Two logging intervals (A and B) can be set up in Chart configuration (Section 4.4.3) to allow automatic printing of log group 1 on the chart. If the memory card option is fitted, archive intervals A and B can also be set up (see section 12) to cause automatic archiving of log group 2.

LOG CONTENTS

Initially, the log group contains all input channels. In order to edit the list, the cursor key is used to move the underline to the item to be added, and the arrow keys used to change its status from included (PV number shown) to excluded (XX shown). The example shows how to delete channel 2 from log group 1.

Adding an item uses exactly the same procedure, with the 'XX' being replaced by the PV number.

When present, optional derived variables, totalisers and counters can be added to any log.

LOG FORMAT

Allows channel tag and /or instrument tag to be included in the log groups 1 and 2. See section 4.5.1 for channel tags, and section 4.3.5 for instrument tag.

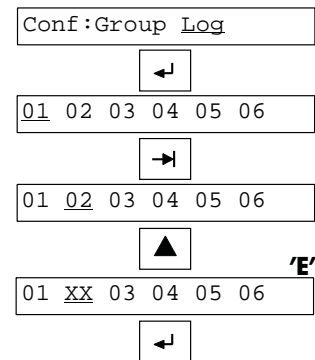

4.6 GROUP CONFIGURATION (Cont.)

4.6.2 DV Group

Allows a number of items to be grouped together for action by a Derived Variable (e.g Group Average) - see section 7 for details. This group can contain all values available to the display and the two logs, but cannot be printed to the chart.

4.6.3 Display Group

The Display group is similar to the Log group described above, except that it determines which PVs appear in the scroll list at the display instead of which PVs are printed on the chart or sent to memory card.

4.7 OPERATOR ACTION CONFIGURATION

This defines the text string (↵ to -----) which appears in the Operator Action page (section 3.6), and whether the trigger is to be latching or non-latching. When used from the Operator Action page, the 'Enter' key acts as a trigger to an 'internal event', and can initiate up to two jobs. See section 4.10 (Internal events) for more details

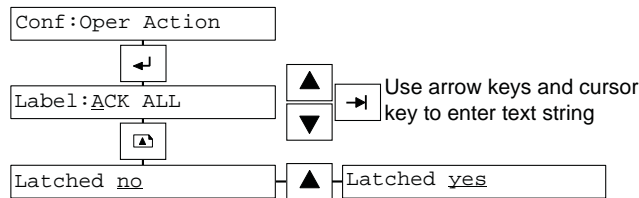

Figure 4.7 Operator action configuration

4.8 CLOCK CONFIGURATION

This part of the recorder's configuration allows you to set the current time and date, and the date format. The time and date are maintained, under power-off conditions, by a nickel-cadmium battery as described in section 3.7.1

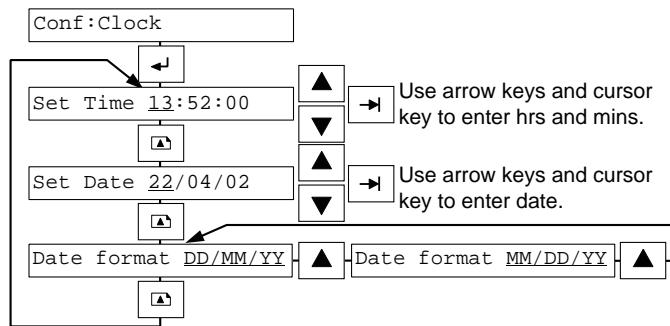

Figure 4.8 Clock configuration pages

4.8.1 Set Time

Use the up/down keys to set the hours. Use the cursor key to underline the minutes field, then the arrow keys to set minutes to the next whole minute. The seconds are set to zero and the clock starts on operation of the enter key.

4.8.2 Set Date

Use the up/down and cursor keys to set the current date

4.8 CLOCK CONFIGURATION (Cont.)

FORMAT

Use the up arrow key to scroll through Day/Month/Year and Month/Day/Year as date formats. It should be noted that if a valid date has not been set up, date format change will not work.

4.9 MESSAGE CONFIGURATION

This part of the configuration allows up to 20 messages to be entered, for display and/or to be printed on the chart as the result of operator or Job action. Entered using the text entry method described in [section 4.1.2](#), these messages can include 'embedded sequences' as described below.

4.9.1 Embedded sequences

Message text is freely editable, and may contain one or more 'Embedded sequence' each of which causes the current value of a particular variable (e.g. time, date, value of channel N) to be automatically included in the message when printed. The sequences are embedded using < and > as delimiters to separate them from one another and from normal text.

Although the message is limited to 20 characters at the display, the embedded sequences will expand fully on the chart or at the memory card (packed data only) if present. The available sequences, which must be entered as shown, are as follows:

ONE PART SEQUENCES

<TIME>	Embeds the current time in hh:mm:ss format
<DATE>	Embeds the current date in the format (DD/MM/YY or MM/DD/YY) defined in clock configuration (section 4.8)
<TMDT>	Embeds time and date

TWO PART SEQUENCES

The remaining sequences require an Item and a Type to be entered either as <Item.Type> or as <Item–Type>. If the latter (hyphen) format is used, the 'Type' will be highlighted if in alarm.

ITEMS

Blank	Uses the triggering item (e.g. alarm) itself as the message triggering source
n	Uses measuring channel n as the message triggering source
Dnn	Uses derived channel nn as the triggering source.
Tn	Uses totaliser n as the source if TCT option fitted
Cn	Uses counter n as the source if TCT option fitted
tn	Uses timer n as the source if TCT option fitted
En	Uses event n as the source.

TYPES

NO	Causes the Item's ID to be embedded (e.g. t2, 06)
PV	Causes the Item's process value to be embedded
TA	Causes the item's tag to be embedded
UN	Causes the Item's units string to be embedded
VU	Causes the items process value and units to be embedded.

4.9.1 EMBEDDED SEQUENCES (Cont.)

EXAMPLES

An alarm going active on channel 3 has 'Print Message 1 on going active' as one of its jobs.

If Message 1 were set up to be: <TIME>< . TA><-PV> then the current time and the tag and process value of channel 3 would be printed on the chart.

If, instead, Message 1 were <TIME><6 . TA><6 -PV> then the current time and the tag and process value of channel 6 would be printed on the chart when the channel 3 alarm went active.

4.10 INTERNAL EVENTS

As standard, there are six internal events, which can be triggered by one or more sources, and which can generate up to two jobs each when active. Input sources can be ANDed or ORed, so multiple logical inputs can be used.

For example, to send a log to the chart when any alarm on channel 1 and channel 2 and channel 4 are active, we could set up events 1 and 2 as follows:

<p>Event 1: Enabled Source 1(S1) AND Source 2 (S2) S1:Alm on channel 1. S2:Alm on channel 2.</p>	<p>Event 2: Enabled S1 AND S2 S1:Alm on channel 4 S2:Event 1</p>	<p>Job 1: Log 1 to chart On going active.</p>
--	--	---

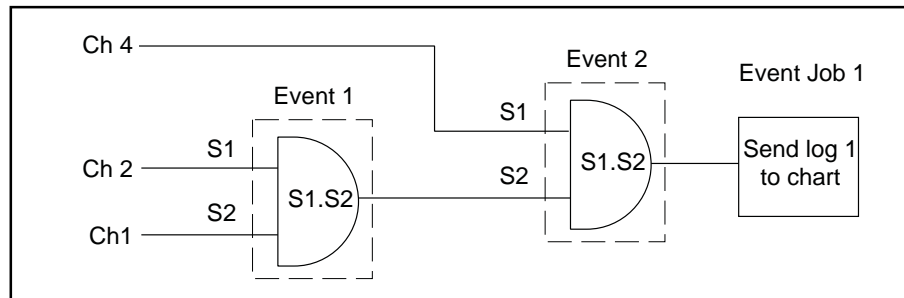

4.10.1 Event sources

Event sources are:

- Alarm on Ch N (any Alarm on specified channel)
- Chart is online (See section 4.4.3 - Stop after One Revolution).
- Clock failure
- Event N (Another specified event - see figure above)
- Glb Channel alarm (Alarm on any channel)
- Glb UnAck Ch Alm (Unacknowledged alarm on any channel)
- Operator Key (See sections 3.6 and 4.7 - Operator action)
- Power up
- System error (Section 3.8)

4.10 EVENT CONFIGURATION (Cont.)

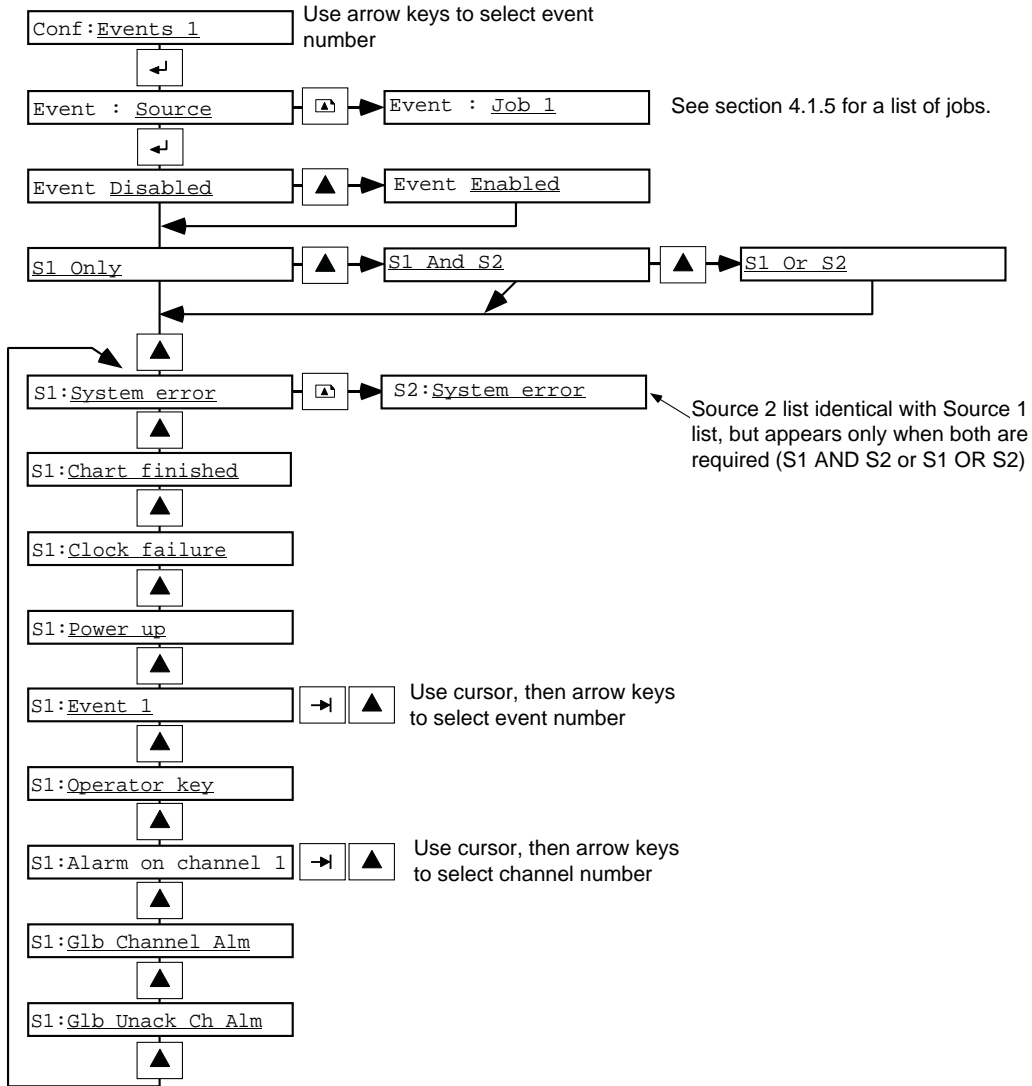

Figure 4.10 Internal event configuration pages

4.11 CONFIGURATION TRANSFER

This facility allows the transfer between recorders, or between the recorder and a host computer (running PC configuration software) using a jack socket located towards the left edge of the recorder platen, near the print head rest position. Only the Baud rate is configurable at the recorder, so data transfer with a host computer, the other settings required are: Eight data bits, One stop bit and No parity.

The configuration transfer circuit is designed for use with TTL (0 to +5V) signals. A converter *may* be required with some host computers to change the signals to the normal RS232 port with 12 Volt signals.

The Transfer function will overwrite the destination recorder's configuration, ensure that the transfer is carried out in the correct direction (i.e. from save to restore)

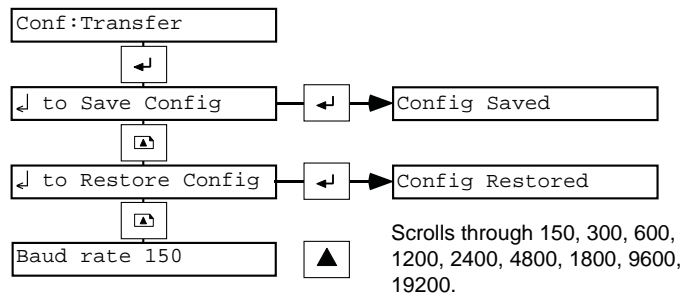

Figure 4.11 Configuration transfer pages.

↓ TO SAVE CONFIG

Operation of the enter key causes the configuration to be saved to another recorder or to a host computer.

↓ TO RESTORE CONFIG

Operation of the enter key causes a new configuration to be retrieved from another recorder or from a host computer.

BAUD RATE

Specifies the number of data bits per second at which the transfer will take place. The setting (150, 300, 600, 1200, 1800, 2400, 4800, 9600, or 19200) must be the same for both sending and receiving devices.

For jack plug wiring, see section 1.2.2

Wiring to computers requires a cable (available from the manufacturer) that has a 9 or 25 pin serial port connector as well as the jack plug for the recorder. Details of this wiring are provided with the available PC configuration software.

4.12 OPERATOR ACCESS

For the sake of security, it is possible to enable/disable certain of the operator functions. These functions are listed below, together with their 'default permissions' (i.e. how they are despatched from the factory).

Switch the chart drive on and off: default = Yes

Initiate Log: default = Yes

Adjust alarm thresholds: default = No

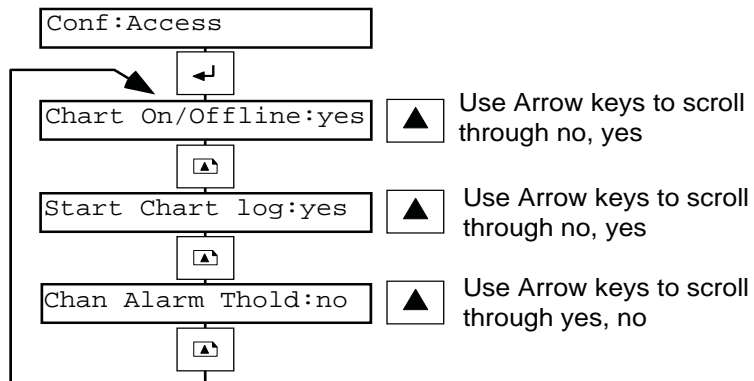

Figure 4.12 Operator permissions pages

4.13 ADJUST

4.13.1 Input adjust

Note: Input boards are permanently calibrated and require no periodic calibration.

This feature allows input channels to be adjusted to make allowance for non-standard inputs.

The technique used is to apply a known input at the low end of the input range for each channel in question. Once the reading displayed by the recorder has stabilized, the 'correct' value is entered. The process is repeated for a value near the high end of the input range.

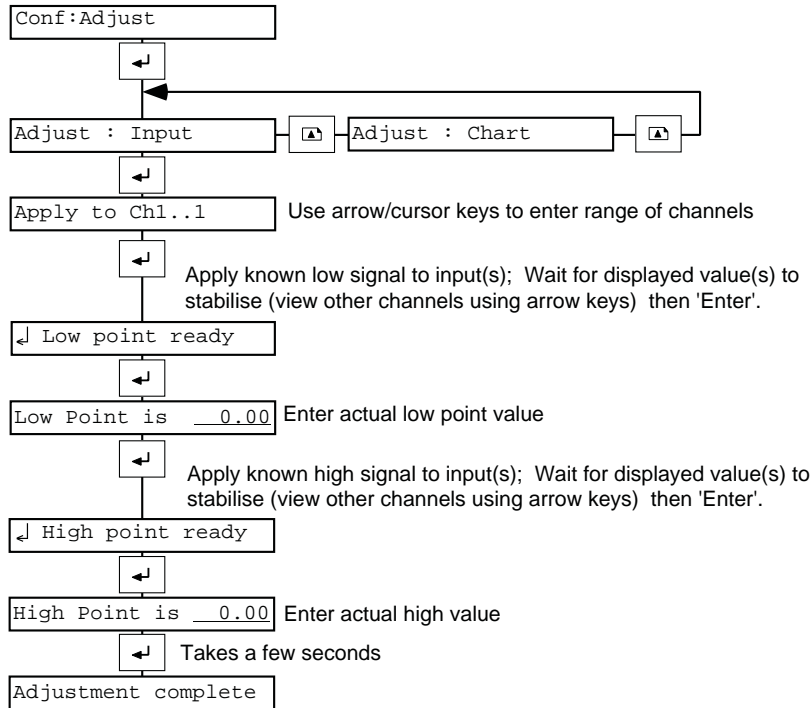

Figure 4.13.1a Input adjust configuration pages

Adjustments can be removed, and channels can be checked to see if they are 'adjusted' as shown in figure 4.13.1b.

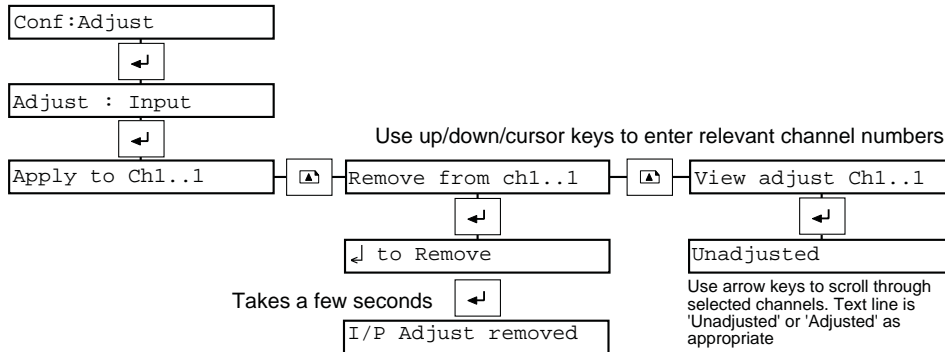

Figure 4.13.1b Remove/View adjust configuration pages

4.13.2 Chart adjust

This feature is the same as the Operator Calibrate Chart feature described in section 3.10

4.14 DEFAULT CONFIGURATION

This section allows the user to return to the factory set configuration. After confirmation has been received, the recorder re-initialises and returns to the background display (section 2.1). As shown in figure 4.14 below, the user can quit before confirmation by using the clear (X) key.

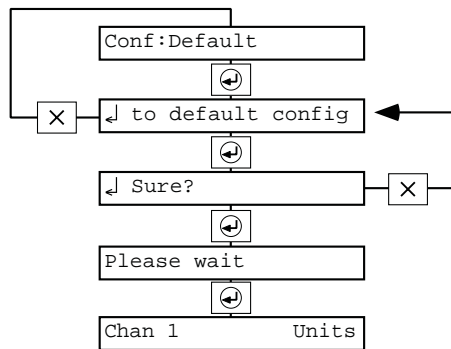

Figure 4.14 Default configuration

4.15 CONFIGURATION MENU SUMMARY

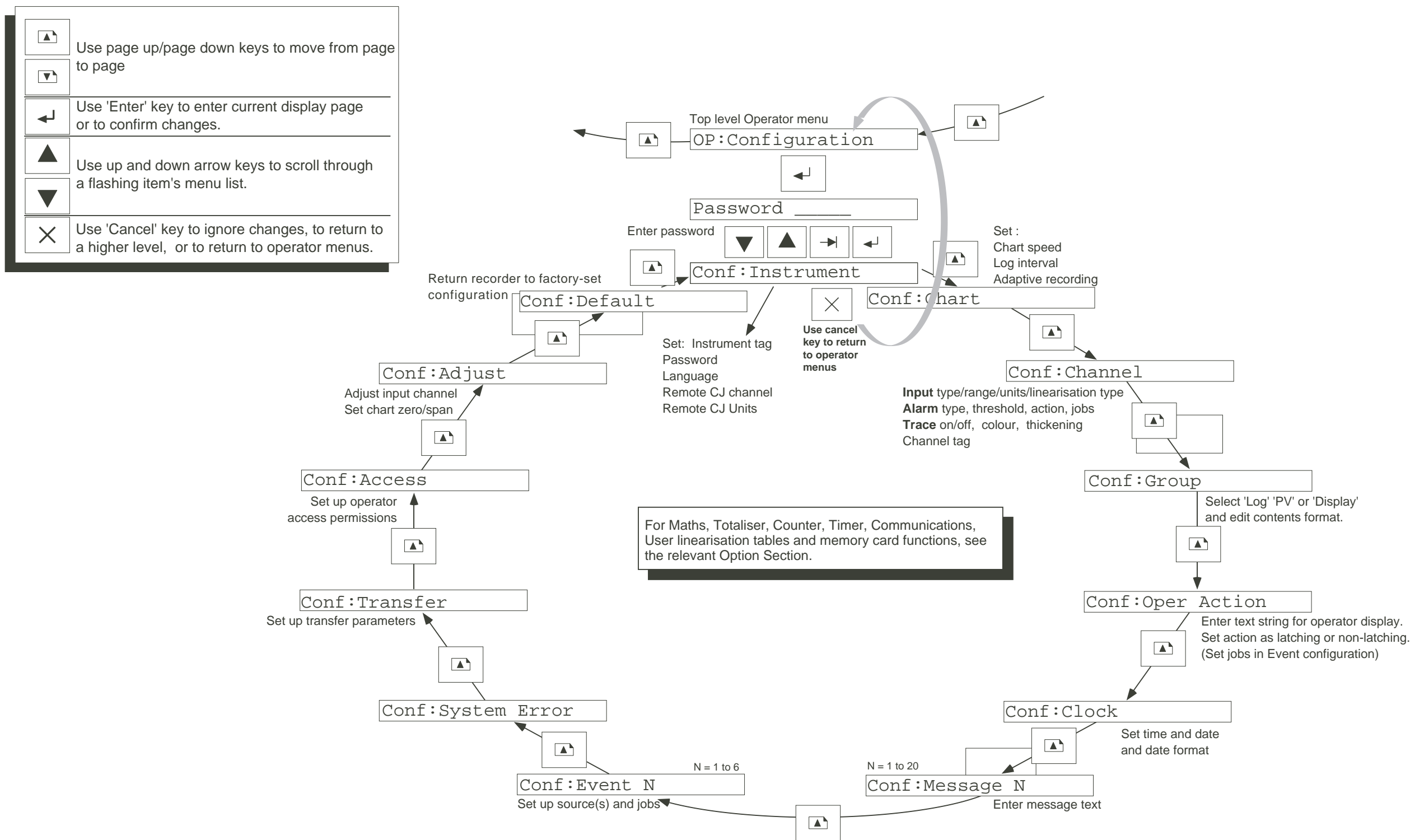

Figure 4.15 Top level Configuration Menu structure

This page is deliberately left blank

5 RELAY OUTPUT OPTION

5.1 INTRODUCTION

The relay output option can have various numbers of relays. A relay board can have two, four or six relays. There can be one, two or three relay boards mounted within the recorder. Each relay has change-over contacts (i.e. common, normally closed and normally open). **In alarm or power off conditions, the common and normally closed contacts are closed.**

5.1.1 Configuration

Alarm types, thresholds etc. are set up as described in section 4.5.2. Each relevant Process Variable can operate one or more relays using jobs.

JOBS

A single job 'Drive relay N of card N' (while active/inactive) is added to the job list shown in Section 4.1.5.

5.1.2 Relay specification

The relay specification for resistive loads is given below. Derate with reactive or inductive loads in accordance with figure 5.1.2, in which:

F1 = Actually measured on representative samples

F2 = Typical values (according to experience)

Contact life = Resistive contact life x Reduction factor.

Number of relays per board	two, four or six
Estimated life	30,000,000 operations
Maximum contact voltage	250V ac
Maximum contact current	2 Amps
Maximum switching power	500 VA or 60 W
Safety isolation (dc to 65Hz; BS EN61010)	Installation category II, Pollution degree 2 (see page 2 for definitions).
Relay to relay:	300 V RMS or dc (double insulation)
Relay to ground:	300V RMS or dc (basic insulation)

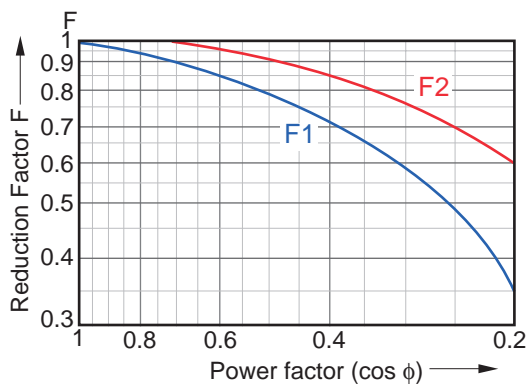

Figure 5.1.2 Derating curves

5.2 RELAY WIRING

The following diagrams show user terminations for the relay output board. Where other options are present, they are always mounted 'after' relay boards (i.e. relay boards always have the lowest option board numbers).

5.2.1 Six change-over (also called Form C or SPDT) relays board

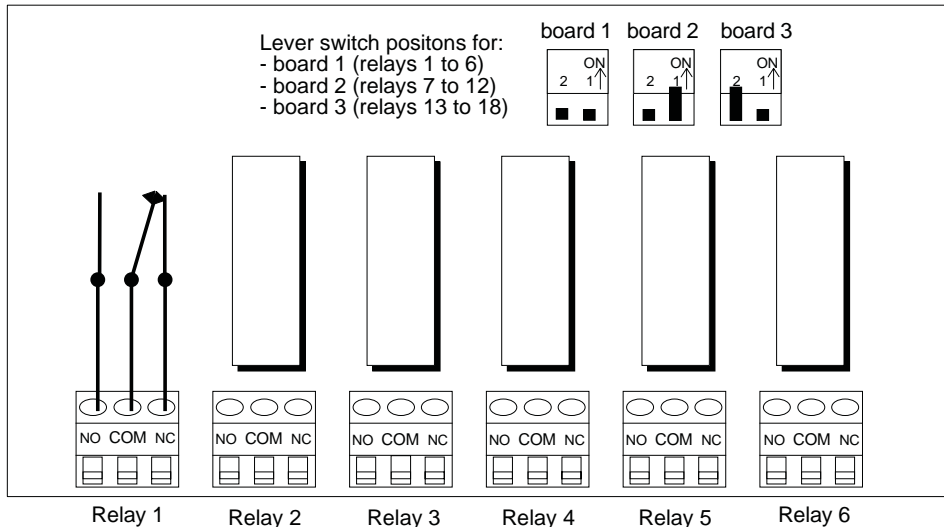

Figure 5.2.1 Change-over relay option wiring

6 ANALOG OUTPUT (RETRANSMISSION) OPTION

6.1 INTRODUCTION

The analog output option provides one card fitted with either 2 or 4 retransmissions of input or math channels, where a configurable proportion of a selected source channel's span is linearly mapped onto a configurable output range. The type of output (Volts or mA) and the output scale, can be set up using the configuration pages described in 6.4, following. Additional outputs cannot be retrofitted later, therefore,

6.2 SPECIFICATION

VOLTAGE OUTPUT

Voltage:	0 to 10 V calibrated (max. current limit 12.3 mA at 11.5 V)
Max. linearity error:	2.0 mV
Min. resolution:	1.6 mV
Max. output resistance:	+/- 2 Ω
Temp. coeff. at zero output:	300 microvolts per deg. C max.
Temp. coeff. of gain:	70 ppm per deg. C of output
Max. output voltage for minimum setting:	-0.3 V at load resistance: 2 k Ω
Min. current limit:	6.0 mA.
Max. series mode high frequency ripple:	150 mV peak to peak
Max. common mode high frequency ripple:	300 mV peak to peak
Nominal output voltage, O/P type set to OFF:	- 1.1 V into open circuit
Max. line regulation (24 V +/- 10%):	370 ppm of output

CURRENT OUTPUT

Current:	0 to 20 mA (max. voltage 18 V at 23 mA)
Max. linearity error:	4.0 μ A
Min. resolution:	3.2 μ A
Min. output resistance:	10 M Ω
Temp. coeff. at zero output:	1.0 μ A per deg. C max.
Temp. coeff. of gain:	80 ppm per deg. C of output
Max. output current for minimum setting:	-0.2 mA at load resistance: 1 k Ω
Max. voltage limit:	30 V into a open circuit
Max. series mode high frequency ripple:	150 μ A peak to peak
Max. common mode high frequency ripple:	300 mV peak to peak
Nominal output current, O/P set to OFF:	-250 μ A into a short circuit
Max. line regulation (24 V +/- 20%):	370 ppm of output

GENERAL

Update rate:	1 Hz.
Step response (10% to 90%):	250 msec maximum
Safety isolation (dc to 65Hz; BS EN61010):	Installation category II; Pollution degree 2 (see page 2 for definitions)
Channel to channel:	300V RMS or dc (double insulation)
Channel to ground:	300V RMS or dc (basic insulation)
Performance:	See table below

Performance in instrument at 20 deg. C +/- 10 deg. C	
Output	Maximum Error
Voltage	11.7 mV + 0.18% of Output
Current	30.5 μ A + 0.21% of Output
These figures do not include errors from the customer's measuring equipment	

6.3 WIRING

Either two or four outputs are present, depending on the installed option.

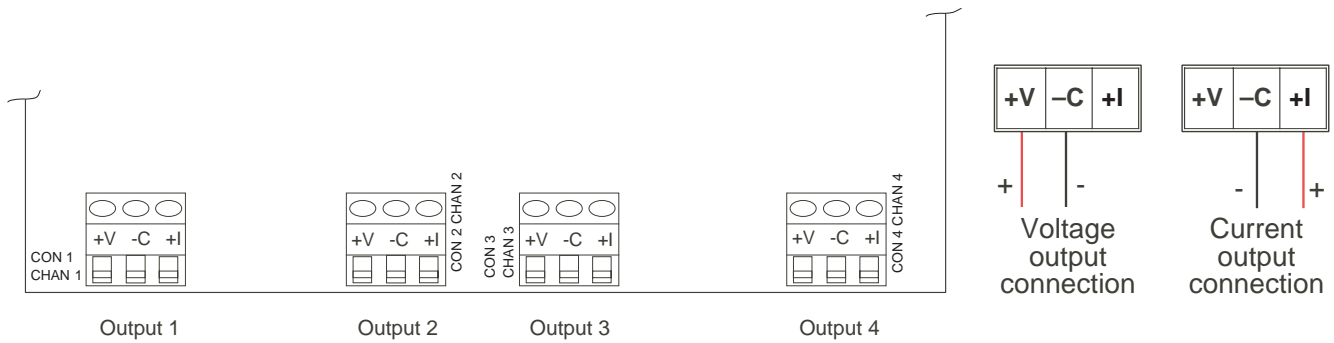

Figure 6.3 Retransmission option wiring

6.4 CONFIGURATION PAGES

Figure 6.4, below, shows a typical retransmission signal configuration. Actual configurations depend on specific applications

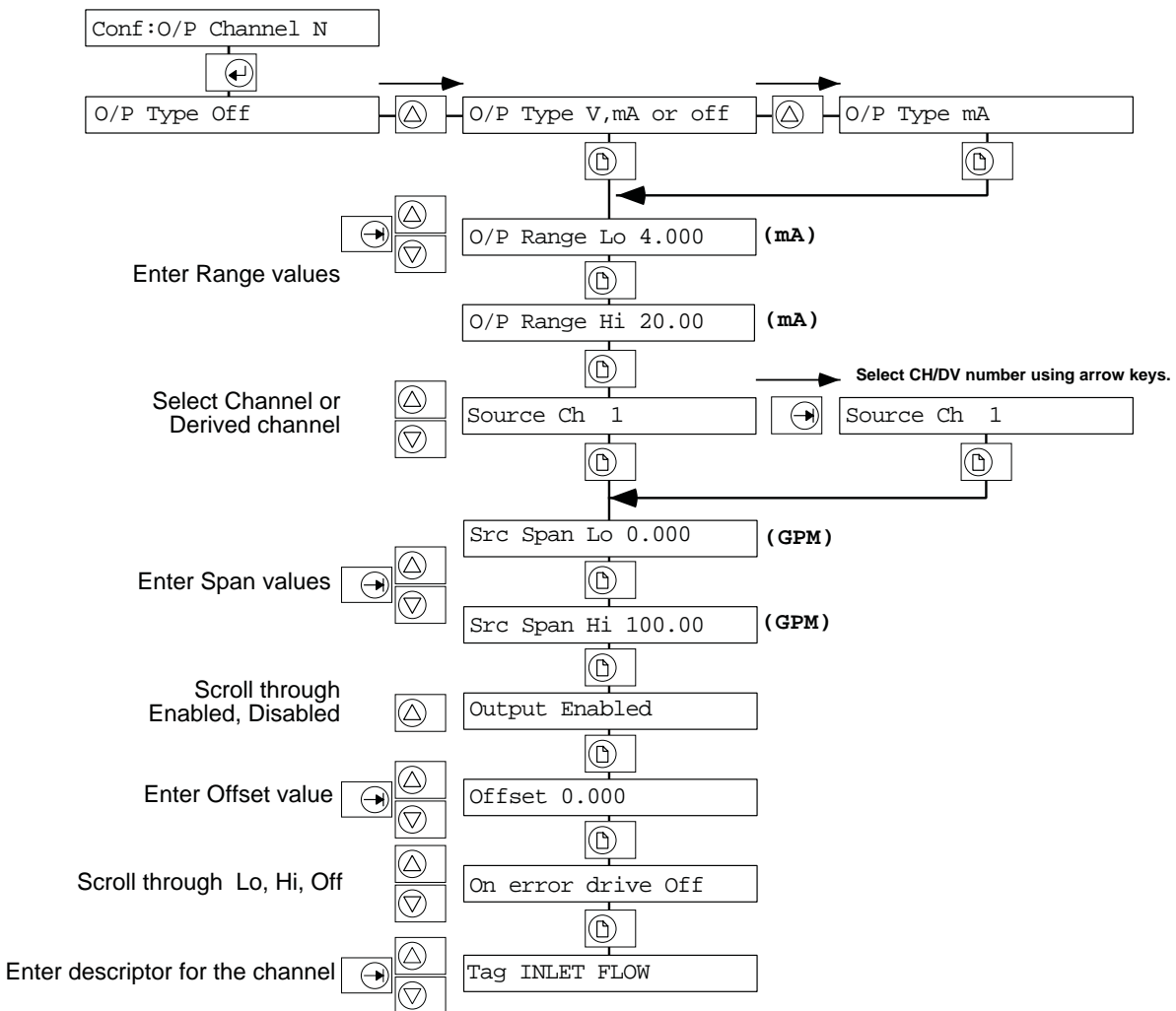

Figure 6.4 Retransmission configuration pages

6.4 CONFIGURATION PAGES (Cont.)

Figure 6.4, above, shows the configuration pages for the analog output option.

O/P Type	Allows V, mA or off to be selected as the output type. <u>WHEN 'OFF', THE CHANNEL OUTPUT GOES TO -250μA AT +I AND -C TERMINALS AND TO APPROXIMATELY -1.1 V ACROSS THE +V AND -C TERMINALS</u>
O/P Range Lo/Hi	Allows the setting of the voltage or current that is to appear at the output terminals when the source signal is at Src Span Lo/Hi (See below).
Source Ch	Allows 'Ch' (measuring channel) or 'DV' (derived channel) to be selected as input source type. When source type is as required, use the cursor key to move to the numeric field and use the arrow keys to scroll through the available channels or DVs.
Src Span Lo/Hi	Allows the setting of the high and low values of the source Ch/DV which cause the high and low values (O/P Range Lo/Hi) of the retransmission output signal.
Output Enabled	Allows the output channel to be switched off, (Disabled) without its configuration being lost.
Offset	Allows a fixed value to be added to the value of the source Ch/DV input to the retransmitter.
On error Drive	Allows Drive off, Drive hi or Drive lo to be selected as an error output (e.g. if the input source is missing). 'Off' causes the output to be set to its off state as defined in O/P type above. 'Drive hi' or 'Drive lo' cause the output to drive to approximately 1% above span or below 'zero' respectively.
Tag	Allows a 14-character descriptor to be applied to the selected channel.

6.5 OUTPUT ADJUST

This feature allows the retransmitted output signal to be adjusted to compensate for differences between the readings on the recorder and readings on the device connected to the retransmission output. The adjustment can be applied or removed as required.

The technique used is:

1. The recorder outputs a known value (10%* of output span) at the analog output terminals.
2. The user takes the resulting value as indicated by the connected equipment and enters it into the recorder.
3. The recorder outputs a second value (90%* of output span).
4. The user takes the resulting value as indicated by the connected equipment and enters it into the recorder.

The recorder then calculates a linear gain and offset correction to be applied to the output.

*These are default values and can be adjusted by the user.

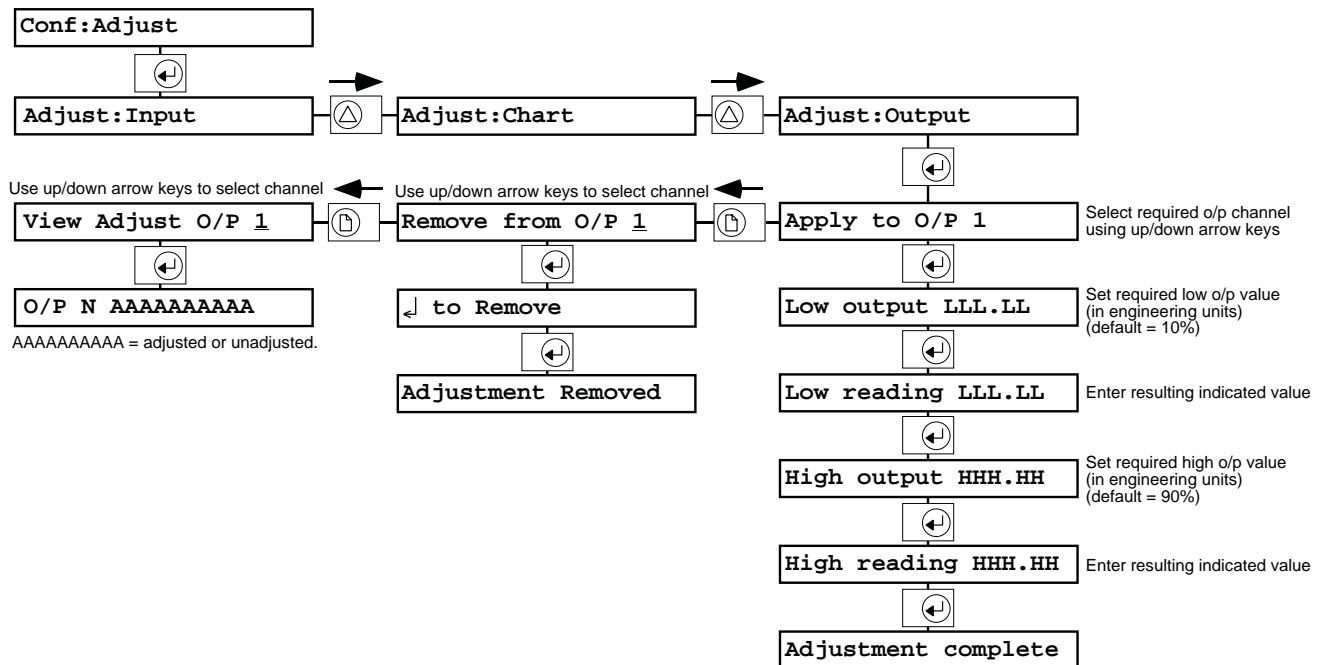

Figure 6.5 Output Adjust menu pages

'Remove' allows the adjustment to be removed from a selected channel.

'View' allows the user to determine whether any particular retransmission output is currently adjusted or not.

7 MATHS PACK OPTION

7.1 INTRODUCTION

The math pack option provides 16 'derived' channels (DV1 to DV16), in addition to the measuring channels.

The option comes in three levels: level 1 which provides basic arithmetic functions, level 2 which provides advanced functions such as averaging, relative humidity calculations, mass flow etc. and level 3 which is a display format only. Scientific notation displays calculated values using a mantissa and an exponent of 10 (e.g. $1000 = 1.00 \times 10^3$). The functions for levels 1 & 2 are listed in table 7.1 below.

Level 1 functions	Level 2 functions (additional to level 1 functions)	
Off	Square root	DV group continuous maximum
Constant	Channel average	Third order polynomial
Copy	DV Group average	Relative humidity
Add	Rolling average	F value
Subtract	e^x	Linear mass flow
Multiply	\log_n	Square root mass flow
Divide	10^x	Zirconia probe
Modulus	\log_{10}	Switch
	Rate of change	High select
	Sample and hold	Low select
	Channel minimum	Stopwatch
	DV group latching minimum	Time stamp
	DV group continuous minimum	O ₂ Correction
	Channel maximum	Percentile
	DV group latching maximum	

Table 7.1 Math functions

7.1.1 Groups

Derived channels can be added to the log and display groups described in section 4.6. The operator can edit these groups to contain only those items which are to be logged or which are to appear at the display.

The Level 2 math pack option adds a further group, called the DV group, which can contain only derived and measuring channels (i.e. not totalizers or counters). The group can be used to assemble channels which are to be part of group averaging, group max/min, or group reset of averages, sample-and-hold, etc.



7.1.2 Jobs

The following jobs are added to the list given in section 4.5.1

- Reset channel NN
- Reset all DVs
- Switch to B on NN
- Disable channel NN
- Disable all DVs
- Trigger Ch NN

7.1.3 Operator pages

If allowed by operator access (section 4.13), the operator can reset any of the resettable functions in level 2 from this menu. The reset page displays the current value of the channel to be reset.

Op Maths <u>1</u>	
	
↵ to reset	37.54
	
Maths channel reset	

7.2 EQUATIONS

Note - Unless otherwise stated, a "channel" can be either an input channel or another derived calculation channel.

7.2.1 Level 1 equations

CONSTANT

Allows the entry of a constant to be used in other equations, values between -99999 and 999999.

Value: <u>1.00</u>

COPY

Can be used to duplicate input or derived channels when more than four alarms are required. Also useful to import totaliser or counter values so they can be traced on the chart and/or, so that they can be used in math calculations.

Copy <u>Ch 1</u>

ADD

Allows one channel to be added to another.

Add <u>Ch 1</u> to Ch 1

SUBTRACT

Allows one channel to be subtracted from another.

Sub <u>Ch 1</u> from Ch 1

MULTIPLY

Allows one channel to be multiplied by another.

Mult <u>Ch1</u> by Ch 1

DIVIDE

Allows one channel to be divided by another.

Div <u>Ch 1</u> by Ch 1

MODULUS

Takes the value of a channel, ignoring sign (i.e. always positive).

Modulus of <u>Ch 1</u>

7.2.2 Level 2 equations

SQUARE ROOT

Takes the square root of the value of a channel. Produces a system error if signal value goes negative.

Square root of Ch 1

CHANNEL AVERAGE

Provides the average value of a channel over a configurable time interval, then repeats.

Average of Ch 1 
Time interval 1m

GROUP AVERAGE

Provides the current average value of all the channels in the DV group i.e.

$$(DVa + DVb + \dots + DVc)/R$$

where R is the total number of DVs in the group.



DV Group average

The function may be globally reset.

ROLLING AVERAGE

Takes the average value of a channel sampled a specified number of times (up to 9999) each at a specified time period in seconds.

Example - a seven minute average can be 42 readings, taken every 10 seconds ($42 \times 10 = 420\text{sec} = 7\text{min}$). The first reading is discarded when the 43rd one is taken and so on.

Average of Ch 1 
Sample Int 10s

Num of Points 42

The function may be globally reset.

E TO THE POWER

Raises e to the power of the value of the specified channel. $e \approx 2.71828$

e To Power of Ch 1

NATURAL LOG

Takes the Naperian log of the value of the specified input or derived channel.

Natural log of Ch 1

10 TO THE POWER

Raises 10 to the power of the value of the specified input or derived channel.

10 to Power of Ch 1

LOG BASE 10

Takes base 10 log of the specified input or derived channel's value.

Log base 10 of Ch 1

7.2.2 LEVEL 2 EQUATIONS (Cont.)

RATE OF CHANGE

Calculates the rate at which the selected channel's value changes over a specified time period, with a specified sample rate which will determine the number of measurements being taken during that time period.

Rate of Chg of Ch 1 

Sample period 1s



Sample rate 1s

SAMPLE AND HOLD

When triggered, retains the current value of the specified channel's value, until reset.

Sample & Hold Ch 1

CHANNEL MINIMUM

Saves the lowest value that the specified channel has reached since initiation or last reset.

Minimum of Ch 1

DV GROUP LATCH MIN

Outputs the lowest value reached by any channel in the DV group since initiation or last reset.

DV Grp Latch Min

DV GROUP CONT MIN

Outputs the current value of whichever channel in the DV group has the lowest value.

DV Grp Cont Min

CHANNEL MAXIMUM

Outputs the highest value that the specified channel has reached since initiation or last reset.

Maximum of Ch 1

DV GROUP LATCH MAX

Outputs the highest value reached by any channel in the DV group since initiation or last reset.

DV Grp Latch Max

DV GROUP CONT MAX

Outputs the current value of whichever channel in the DV group has the highest value.

DV Grp Cont Max

THIRD ORDER POLYNOMIAL

Provides a third order polynomial curve fit:

$$A0 + A1x + A2x^2 + A3x^3$$

where A0 to A3 are constants and x is the specified channel's value.

Constants less than 0.0001 or greater than 99999 require further configuration to execute, consult factory.

Polynomial of Ch 1 

A0 1.00



A1 1.00



A2 1.00





A3 1.00

7.2.2 LEVEL 2 EQUATIONS (Cont.)

RELATIVE HUMIDITY

To determine the relative humidity percentage using wet and dry temperature readings in °F and atmospheric pressure inputs in bars. 1 bar = 14.7 psia.

The mantissa of the psychrometric constant times the pressure should equal 6.66 - e.g. a 0.9 bar times a 7.40 constant equals 6.66; (the exponent "-4" is fixed).

Wet temp Ch 1	
Dry temp Ch 1	
Atm Pressure Ch 1	
Psych Const <u>6.66</u> -4	

F VALUE

To calculate the equivalent time at Sterilizing Temperature (for temperatures below, at and above Sterilizing Temperature) both in dry (F_H) and steam (F_o) sterilizing environments, using the following equation:

$$Fval_t = Fval_{t-1} + T \times 10^{\frac{ma_t - target\ temp}{Z}}$$

Where Fval_t = F value at time t (minutes)

Fval_{t-1} = F value last iteration



T = Internal recorder iteration rate (minutes)

ma_t = Value of temperature measuring channel

Target temp = 121.1°C for F_o; 170°C for F_H

Z = Temperature interval representing a factor-of-10 reduction in killing efficiency

= 10°C for F_o; = 20°C for F_H

F value Ch 1	
Ster. Temp <u>1.00</u>	
Z Value <u>1.00</u>	

7.2.2 LEVEL 2 EQUATIONS (Cont.)

MASS FLOW LINEAR

Note: the overall accuracy of a flow measurement installation depends on a number of factors outside the control of the recorder manufacturer. For this reason, the manufacturer takes no responsibility for the accuracy of results obtained by using the mass flow equations implemented in the maths pack.

Independent verification is recommended before this recorder is used for custody transfer.

The equation solved is:

$$Qm_t = \frac{K}{Rg \times Z} \times \frac{Flow_t \times AbsP_t}{Temp}$$

where: Qm_t = mass flow at time t, in the same flow units as 'Flow_t'.

$Flow_t$ = measured value from the flow meter at time t

$AbsP_t$ = absolute pressure of the fluid at time t

$Temp$ = absolute temperature of the fluid in Kelvins

K = scaling factor (see below)

Rg = specific gas constant in J/(kg-K) (see below)

Z = compressibility factor (see below)

For the recorder user, this becomes:

$$\text{Mass flow} = \frac{md \times ma_t \times mb_t}{mc_t}$$

where: ma_t = the value, at time t, of the channel measuring the flow meter output

mb_t = the value, at time t, of the channel measuring the absolute pressure of the fluid

mc_t = the value, at time t, of the channel measuring the fluid temperature in Kelvins

md = a constant, derived from the equation:

$$\text{Const} = \frac{K}{Rg \times Z}$$

where: K = a scaling factor (see below)

Rg = specific gas constant in J/(kg-K) (see below)

Z = compressibility factor (see below)

SCALING FACTOR K

This is derived from the equation:

$$K = \frac{S}{ma_{\max}}$$

where: S = The full scale output from the flow meter

ma_{\max} = the full scale input of the channel which is reading the flow meter output

SPECIFIC GAS CONSTANT (Rg)

The specific gas constant values are available from published tables.

For convenience, the Rg values for a number of common gases are given in table 7.2

Gas	RG (J/kg-K)
Air	287.1
Ammonia	488.2
Carbon dioxide	188.9
Carbon monoxide	296.8
Ethylene	296.4
Hydrogen	4116.0
Methane	518.4
Nitrogen	296.8
Oxygen	259.8
Propane	188.5
Steam	461.4

Table 7.2 Common gas constants

7.2.2 LEVEL 2 EQUATIONS (Cont.)

COMPRESSIBILITY FACTOR (Z-FACTOR)

The compressibility factor is a density-related measure of how far a particular gas deviates from a 'perfect' gas under any set of temperature and pressure conditions, and is given by the equation:



$$Z = \frac{P}{T} \times \frac{1}{\rho}$$

Where: Z = Compressibility factor
P = Absolute pressure of the gas
T = Absolute temperature of the gas
 ρ = Gas density at pressure P and temperature T (from published tables)

Alternatively, the Z-factor can be established experimentally.

CONFIGURATION PAGES

Enter the flow rate, absolute temperature and the absolute pressure channels and the constant

Flow Ch 1	
Temperature Ch 1	
Abs Press Ch 1	
Constant 1.00	

7.2.2 LEVEL 2 EQUATIONS (Cont.)

MASS FLOW SQUARE ROOT

Note: the overall accuracy of a flow measurement installation depends on a number of factors outside the control of the recorder manufacturer. For this reason, the manufacturer takes no responsibility for the accuracy of results obtained by using the mass flow equations implemented in the maths pack.

Independent verification is recommended before this recorder is used for custody transfer.

The equation solved is:

$$Qm_t = \sqrt{\frac{K^2}{Rg \times Z}} \times \sqrt{\frac{\text{Delta}P_t \times \text{Abs}P_t}{\text{Temp}_t}}$$

where: Qm_t = mass flow at time t, in the same flow units as 'Flow_t'.

$\text{Delta}P_t$ = measured value of the differential pressure across the orifice plate at time t, in kPa.

$\text{Abs}P_t$ = absolute pressure of the fluid at time t

Temp_t = absolute temperature of the fluid in Kelvins

K = scaling factor (see below)

Rg = specific gas constant in J/(kg-K) (see below)

Z = compressibility factor (see below)

For the recorder user, this becomes:

$$\text{Mass flow} = \sqrt{\frac{md \times ma_t \times mb_t}{mc_t}}$$

where: ma_t = the value, at time t, of the channel measuring the flow meter output

mb_t = the value, at time t, of the channel measuring the absolute pressure of the fluid

mc_t = the value, at time t, of the channel measuring the fluid temperature in Kelvins

md = a constant, derived from the equation:

$$\text{Const} = \frac{K^2}{Rg \times Z}$$

where: K = a scaling factor (see below)

Rg = specific gas constant in J/(kg-K) (see linear mass flow above)

Z = compressibility factor (see linear mass flow above)

SCALING FACTOR K

This is derived from the equation:





$$K = \frac{S}{\sqrt{ma_{\max}}}$$

where: S = The full scale output from the flow meter

ma_{\max} = the full scale input of the channel which is reading the flow meter output

CONFIGURATION PAGES

Enter the differential pressure, absolute temperature and the absolute pressure channels and the constant

Differ Press Ch 1	
Temperature Ch 1	
Abs Press Ch 1	
Constant 1.00	

7.2.2 LEVEL 2 EQUATIONS (Cont.)

ZIRCONIA PROBES

A zirconia (oxygen) probe consists of two platinum electrodes bonded to a pellet or cylinder of zirconia. At elevated temperatures, such a probe develops an emf across it which is proportional to probe temperature and to the log of partial pressure of oxygen difference between its two ends.

OXYGEN CONCENTRATION MEASUREMENT

In order to measure oxygen concentrations, one end of the probe is inserted into the atmosphere to be measured, while the other is subjected to a reference atmosphere. For most applications, air provides a suitable reference (reference input = 20.95% for air).

The temperature of the probe is usually measured using a type K or a type R thermocouple. The temperature effect on the thermocouple is such that for successful operation with the recorder, the probe temperature must be greater than 973K (700°C).

The probe output obeys a law, described by the Nernst oxygen equation:



$$P_2 = \frac{P_1}{10^{\frac{E}{0.0496 \times T}}}$$

where, P_2 = Partial pressure of oxygen in the sampled gas (%)
 P_1 = Partial pressure of oxygen in the reference atmosphere (%) (20.95% for air)
 E = Electromotive force across the probe in mV
 T = Probe temperature in Kelvins

In order to obtain a useful result, it is necessary to scale the inputs and outputs correctly. The channel measuring the probe voltage will normally need a scale of 0 to 100 mV. The temperature measuring channel will probably be scaled at 273 to 1800K, while the output scaling would typically be 0 to 5 % for boiler flues, and 0 to 20% in kilns.

CONFIGURATION PAGES

Enter channel numbers for Probe temperature, Probe emf and reference % measurements.

Probe temp	Ch 1	
Probe EMF	Ch 1	
Reference	1.00	

7.2.2 LEVEL 2 EQUATIONS (Cont.)

ZIRCONIA PROBES (Cont.)

OXYGEN POTENTIAL MEASUREMENT

The oxygen potential of an atmosphere is a measure of its ability to oxidise or reduce. For any element, a value of oxygen potential (free energy of formation) is known. Above this value, the material will oxidise, below it, no oxidation will occur.

Oxygen potential is given by the equation:

$$Op = 0.00457 \times T \times \log Op'$$

where, Op = Required oxygen potential (kilocalories)

T = Probe temperature (Kelvin)

Op' = Partial pressure of oxygen in the reference atmosphere in atmospheres

It can be shown that, because oxygen potential of air is essentially constant over the range 870 to 1450 Kelvins, the probe output is proportional to the oxygen potential of an atmosphere according to:

$$E = (10.84 \times T) + 40mV \text{ between } 870 \text{ to } 1450 \text{ K.}$$

Thus it is possible to measure oxygen potential directly from a zirconia probe, using a standard input channel of the recorder, scaled in units of oxygen potential.

A typical input range would be 40 to 1124 mV, with a scale of 0 to -100 kilocalories. Such scaling would be appropriate over the temperature range 873 to 1473 K (600 to 1200 °C).

SWITCH

This function copies one of two channel values according to the state of its 'Select channel B for NN' job. I.E. if the relevant switch is active, copy the value of source channel B, else copy the value of source channel A.

Switch Ch A Ch 1

Switch Ch B Ch 1

HIGH SELECT

This function has two channel inputs, and copies whichever has the higher value.

Higher of Chs 1, 1

LOW SELECT

This function has two channel inputs, and copies whichever has the lower value.

Lower of Chs 1, 1

STOPWATCH

The stopwatch starts counting as soon as the function is configured. The stopwatch can be held (disabled) by a maths pack 'job, (disable channel NN) and can also be reset to zero (Reset channel NN). The value is normally displayed as a number of 1/4 seconds, but if one of the date/time formats described in section 7.3 is selected, the value can be displayed in hours/minutes/seconds. When logged to the chart, it will appear in the specified format .

7.2.2 LEVEL 2 EQUATIONS (Cont.)

TIME STAMP

When triggered by a maths pack job (Trigger channel NN) becoming active, the time stamp reads the current time and date from the system clock and holds it. The time or the date can be displayed according to the configured value format.

Note: The display format selected affects only the value displayed, not the internal value of the channel. This internal value is a number of 1/4 seconds elapsed either since enabled (stopwatch) or since the 1st January 1988 (Time stamp). This allows time stamp functions to be processed in the maths pack. For example, two channels, each with a time stamp as its value can be subtracted from one another to give the time between the stamps, and this can be displayed as elapsed time if so configured in the Value Format page.

OXYGEN (O₂) CORRECTION

This function carries out O₂ correction of gas measurements for use in Continuous Emissions Monitoring (CEM) applications.

The equation calculated is:

$$Qmt = \frac{20.9\% - Spec O_2}{20.9\% - Meas O_2} \times Meas. gas$$

where,

Spec. O₂ = specified oxygen entered as a constant 5-digit value (prescribed for the particular process).



Meas. O₂ = measured oxygen, entered as a channel number (gas analyser input)

Meas. gas = the measured gas, entered as a channel number (gas analyser input)

NOTE: If the measured O₂% were to go below the specified O₂%, the above calculation will result in a compensated gas measurement that is **less than the actual measured gas value. This may not be allowed by some regulatory agencies.**

To prevent the calculated value from going lower than the measured value, add a "High Select" DV channel with inputs from the measured gas channel and the O₂ calculation above (*Qmt*). Since this DV selects the highest of its two input values, the actual measured gas channel value will be chosen when the *Qmt* calculation is lower. This High Select is now the compensated gas DV channel to be displayed, recorded, etc. rather than the above *Qmt* calculation.

CONFIGURATION PAGES







Fn:O2 Correction	
Spec Oxygen 1.000	
Meas Oxygen Ch 1	
Meas Gas Ch 1	

7.2.2 LEVEL 2 EQUATIONS (Cont.)

PERCENTILE

This function looks at a specifiable number of the most recent samples of a specified channel. It continuously calculates the percentage of these samples which are equal to or which lie within a specifiable limit. The limit can be a high limit or a low limit. (e.g. - the percentage of the last 20 samples that are equal to or less than 100°F).

Once the specified number of samples has been reached, the oldest sample is discarded and the percentage re-calculated with each new sample. The sample rate can also be specified.

Fn:Percentile		
Source Ch 1		
Threshold 1.0000		
Limit is High		Scroll through 'high' and 'low'
Sample int 1s		
Num of Points 1		Use minimum number of points you can, to save memory space.

7.3 CONFIGURATION

Figure 7.3 is an overview of the maths pack configuration pages

The configuration technique for derived channels is similar to that described for measuring channels in section 4.5, above. Input and derived channels share the following parameters:

Channel units	Five character user definable string	
Trace	On, off	
Line thickening	On, off	
Colour	Selectable from those available	
Span	A and B	
Tag	14-character tag	
Alarms	Type, threshold, jobs	
Value format	Level 1 & 2 Functions:	Five digits with configurable decimal point position.
	Level 3 Functions	Two digits (positive) or one digit (negative) plus the exponent (-9 to 9).

MATHS PACK UNIQUE PARAMETERS

GROUP RESET ENABLE

Allows resettable functions to be made susceptible to group reset.

LEVEL 2 VALUE FORMATS

Value format	Five digits with configurable decimal point position.
	<u>Time</u> as HH:MM:SS (Time part of time stamp function, or elapsed time for the stopwatch).
	<u>Date</u> as DD/MM/YY or MM/DD/YY (Date part of Time Stamp function). Date format is defined as a part of instrument configuration.
	Elapsed time as HH:MM:SS. If the period is 100 hours or more, the format changes to HHHHH:MM.

Note: If a DV is configured with one of the above Date, Time or Elapsed formats, it will be displayed as -----, but will be logged on a separate line in the chosen format.

This page is deliberately left blank

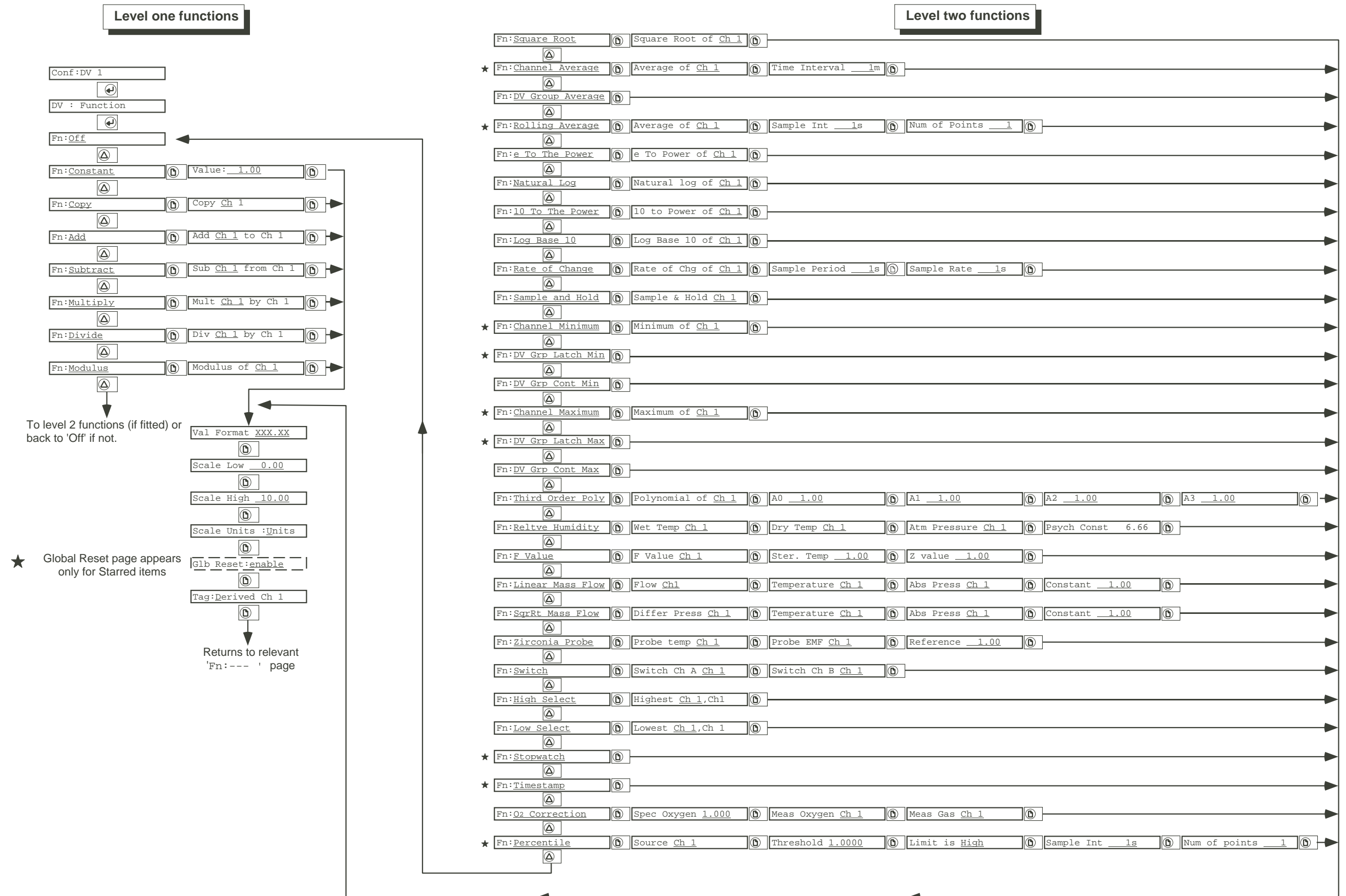

Figure 7.3 Maths pack configuration menu structure

This page is deliberately left blank

8 TOTALISERS, COUNTERS AND TIMERS

8.1 INTRODUCTION

The Totaliser, Timer/Counter and Totaliser/Timer/Counter options supply up to six each of 9-digit (8-digit when decimal point used) totalizers, 8-digit counters and clock timers.

8.2 TOTALISERS

8.2.1 Source types

Each totaliser can integrate a given input or derived channel's value providing this value is between the totaliser's configured low cut-off point and high cut-off point and within the channel's configured range.

8.2.2 Alarms

An alarm threshold can be set up for each totaliser, and each threshold can have up to two jobs associated with it. A 'limit' setting defines whether the job list is to be initiated when the totaliser value lies above (high) or below (low) the threshold value. Up to two jobs can be initiated by the alarm.

8.2.3 Display

The Display Group (described in section 4.6) is initially empty. With the TCT option, totalizers can be included in the display group with identifiers t1 to t6. It is up to the user to include totalizers in each group as required.

The value and units of each totaliser in the Display Group are displayed, in turn, in the 20-character text area. (The decimal point position is set up in the 'Value Format' configuration page.) Operation of the page key displays the totaliser tag and units instead.

8.2.4 Tracing on the chart (maths pack level 1 required)

To trace the value of a totaliser on the chart, it must be imported into a derived channel (using the 'Copy' function), and the derived channel then traced.

8.2.5 Operator pages

If operator access is allowed, the operator can preset individual totalisers, and can edit the preset value.

Op:Totalizer 1
←
↓ preset nn.nn
Ⓜ
Ed Preset _____ 0.00

8.2.6 Totalizer configuration

Configuration is carried out using the normal techniques described in section 4. Figure 8.2.6 below, shows the configuration pages.

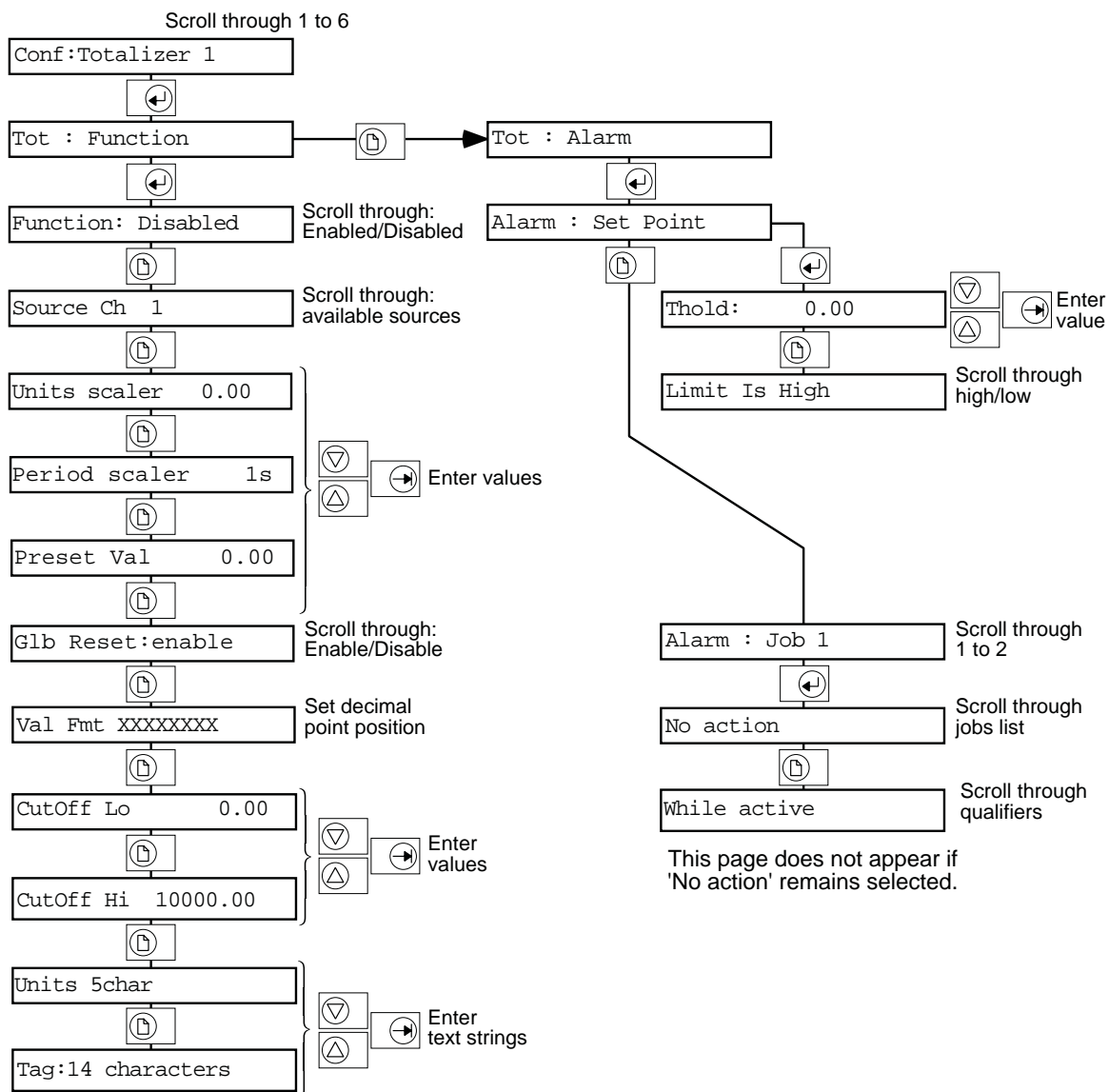

Figure 8.2.6 Totalizer configuration

8.2.6 TOTALIZER CONFIGURATION (Cont.)

Source	Allows input channels or derived channels to be selected as totalizer sources
Units scaler	Allows the counting to be scaled. For example, if the input to a storage tank is gallons/min and the totalizer value is to be gallons $\times 10^3$ (i.e. one count for each thousand gallons), then the units scaler would be set to 1000. A units scaler greater than 1.0 causes the totalizer to run slower by the size of the scaler (counts divided by scaler). A units scaler less than 1.0 causes the totalizer to run faster.
Period scaler	The totalizer reads the source channel value every second. The period scaler defines the time value of the input units (/sec, /min, /hr, etc). Except as (*) below, the period scaler is ALWAYS the number of seconds. For example, if the input is in gallons/minute, then the period scaler would have to be the number of seconds in a minute (60). The larger the period scaler, the slower the totalizer counts.

Examples	<u>Measured Value</u>	<u>Units Scaler</u>	<u>Period Scaler</u>	<u>Each Count Is</u>
	Pounds per Second	1.0000	1	1 Pound
	Pounds per Second	1000.0	1	1000 Pounds
	Standard Cubic Feet per Minute	1.0000	60	1 Cubic Foot
	Gallons per Hour	1.0000	3600	1 Gallon
	Gallons per Hour	100.00	3600	100 Gallons
	Millions of Gallons per Day	10.000*	8640*	1 Million Gallons*
	Millions of Gallons per Day	0.0100**	8640**	1000 Gallons**

* The period scaler would normally be 86,400 (the number of seconds in a day), but the entry for the period scaler only allows a maximum of 4 digits. This means that 86,400 cannot be entered directly. A 4-digit period scaler of 8640 is 10 times too small and makes the totalizer count 10 times too fast. However, also changing the units scaler to 10 makes the totalizer count 10 times slower and makes the millions in the totalizer correct (10 X 8640 = 86,400).

** Since it is unlikely that anyone would want each count on a totalizer to represent a million gallons, the units scaler can be reduced by a factor of 1000 resulting in a totalizer that counts in 1,000's of gallons (0.01 X 8640 = 86.400).

Preset value	Allows the entry of a nine-digit (eight digit when decimal point is used) number from which the totalizer will count. Totalizers can be set to their preset values, either individually or as a group, by job action or individually by the operator, if access permission is granted. See also 'Glb Preset Disable' immediately below. Preset to 0.000000 "resets" the totalizer.
Glb Reset	Allows each totalizer to be configured to be susceptible to global reset (Enable) or not (Disable).
Val format	Allows the decimal point position to be specified using the up and/or down arrow keys.
Cut Off Lo(Hi) Units	Allows cut-off values to be entered, below (above) which the totalizing function will be disabled. Allows a 5-character text string to be entered to describe the totalizer units.
Tag	Allows a 14-character descriptive text string to be entered.

ALARM PAGES

Threshold	Allows a value to be entered to act as an alarm trigger.
Limit	Defines whether the alarm triggers when the totalizer value is \geq the threshold (absolute high alarm) (limit = high) or \leq the threshold (absolute low alarm) (limit = low)
Jobs	The following jobs are added to the scroll list given in section 4.1.5: Preset Tot N Preset all Tots Disable all Tots

8.3 TOTALIZER COUNTER OUTPUT

The totalizer counter output option provides a pulse output to an assigned relay which is scaled to the count on the associated totalizer. There are two entries for this feature (see figure 8.2.6).

O/P (output)factor: divide the totalizer value, e.g. a factor of 100 outputs a pulse every 100 totalizer counts. A factor of 0.00 disables the output.

Pulse Relay "n" of card "n":

8.4 COUNTERS

8.4.1 Introduction

The counter options supply six, eight-digit counters which are controlled from other recorder functions through job lists. The following jobs are added to the list given in section 4.1.5. They can all be triggered when the source goes active, goes inactive or on alarm acknowledgment, as configured:

1. Increment Counter N
2. Decrement Counter N
3. Preset counter N
4. Preset all counters
5. Disable all counters

Each counter can be configured with a threshold value to enable it to trigger up to two jobs itself. A 'limit' input allows a job list to be initiated either when the counter value \geq the threshold (limit high) or when it is \leq the threshold (limit low).

8.4.2 Tracing on the chart (maths pack level 1 required)

To trace the value of a counter on the chart, it must be imported into a derived channel (using the 'Copy' function), and the derived channel then traced.

8.4.3 Display

The Display Group (section 4.6.3) is initially empty. With the TC or TCT option, counters can be included in the display group with identifiers Co1 to Co6. It is up to the user to include counters in the group as required.

The value and units of each counter in the Display Group are displayed, in turn, in the 20-character text area. (The decimal point position is set up in the 'Value Format' configuration page). Operation of the page key displays the counter tag and units instead.

8.4.3 Operator pages

If operator access is allowed, the operator can preset individual counters, and can edit the preset value. Initiation of preset can also be carried out by job action on individual channels or on all channels simultaneously.

Op:Counter 1
←
↓ preset nn.nn
⏏
Ed Preset 0.00

8.4.4 Configuration

Configuration is carried out using the normal techniques described in section 4. Figure 8.4.4, shows the configuration pages.

- Preset Eight digit value of preset, entered using the up and down arrows. The preset value is loaded into the counter by job or by operator action.
- Units Allows a 5-character units string to be entered using the up/down arrows and cursor key.
- Glb preset Allows each counter to be defined as being susceptible to global reset (enable) or not (disable).
- Tag Allows a 14-character descriptive tag to be entered for each counter.

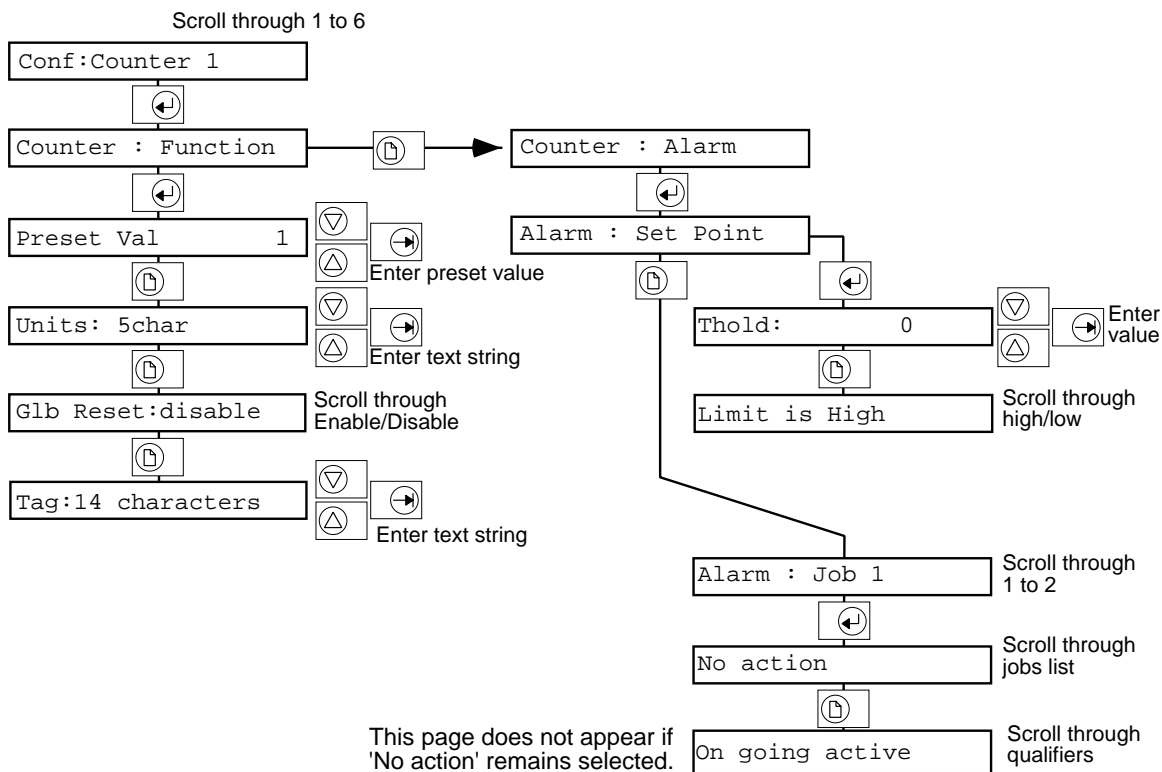

Figure 8.4.4 Counter configuration

ALARM PAGES

- Threshold Allows a value to be entered to act as an alarm trigger.
- Limit Defines whether the alarm triggers when the counter value is \geq the threshold (absolute high alarm) (limit = high) or \leq the threshold (absolute low alarm) (limit = low)

8.5 TIMERS

8.5.1 Introduction

The timer options supply six timers, each of which can be configured to start at a specific time and date relative to the real-time clock in the recorder. Once initiated, the timer will run for a configurable time period (duration) and repeat at a configurable rate. Alternatively, the timer can be initiated by a job, and it will then repeat at the configured repetition rate. Once initiated, the timer will restart every repeat period until it is disabled.

Each timer can have up to two jobs associated with it, and continuous jobs (e.g. chart speed change) remain active for the full time of the timer duration period. "One shot" jobs (e.g. resetting a totaliser) can be defined to occur as the timer is "going active" or "going inactive".

The timer options add the following jobs to the list given in section 4.1.5:

- Start specified timer - resets and starts timer
- Reset specified timer - resets but does not start timer

8.5.2 Operator pages

If access permission is granted, the operator can start or reset a timer

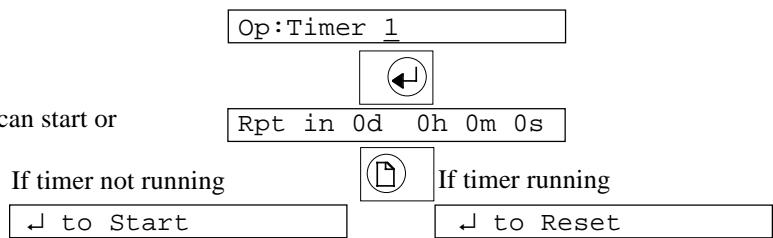

8.5.3 Configuration

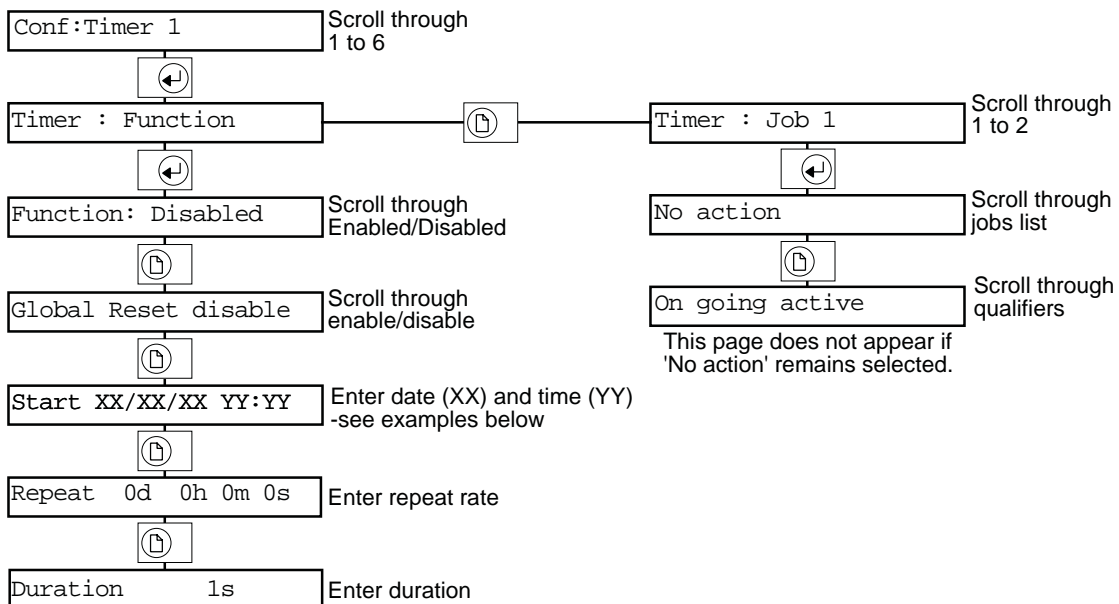

Figure 8.5.3 Timer configuration pages

8.5.3 TIMER CONFIGURATION (Cont.)

Function	Allows the timer to be switched on or off
Global reset	Allows each timer to be configured to be susceptible to global reset (enable) or not (disable)
Start	Allows a date and time to be entered for the timer to start. If an entry is left as XX, the timer will operate at the next smallest time unit. <u>If all entries are left as XX, the timer can be started only by job or by operator action</u>
Repeat	Allows a repeat period to be entered. If entries are left as zeros, the timer does not repeat.
Duration	Allows a duration period to be entered for the timer

JOBS PAGES

Allows up to two jobs to be entered for the timer to trigger.

8.5.4 Timer examples

1. To start a timer at mid-day on the 1st of each month:

```
Start XX/01/XX 12:00
```

2. To start a timer every hour, on the 1/2 hour, starting at 12:30 on 31st December:

```
Start 31/12/XX 12:30
```

```
Repeat 0d 1h 0m 0s
```

9.3 WIRING (Cont.)

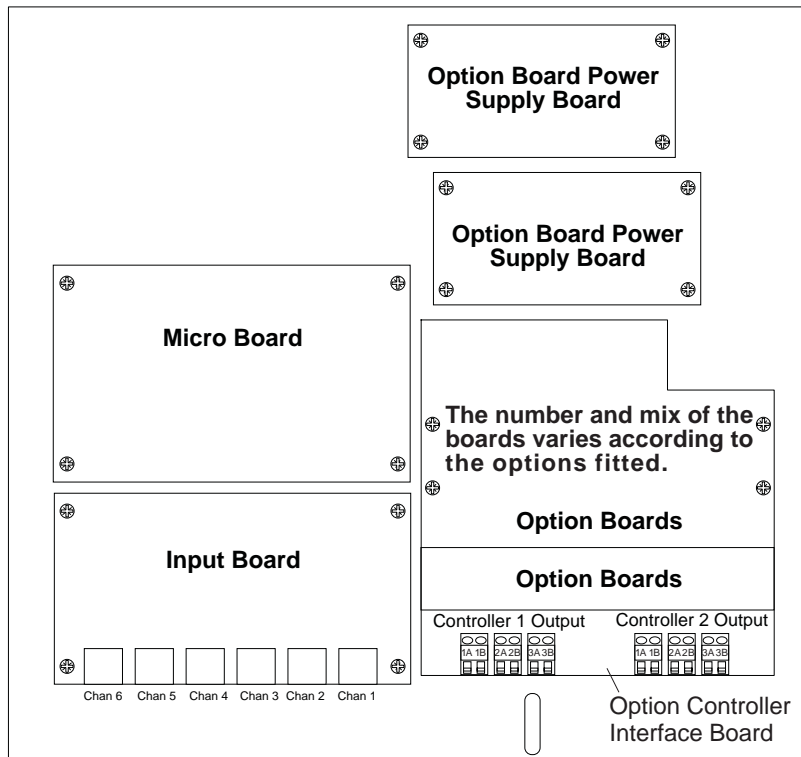

Figure 9.3.1 Controller output and PV data

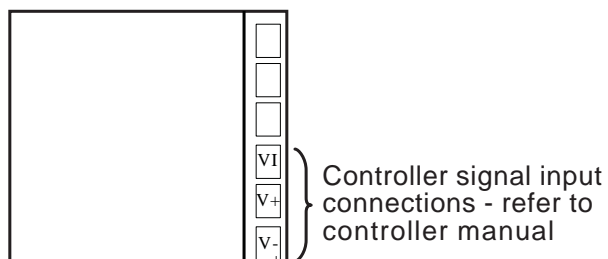

Figure 9.3.2a Controller signal inputs

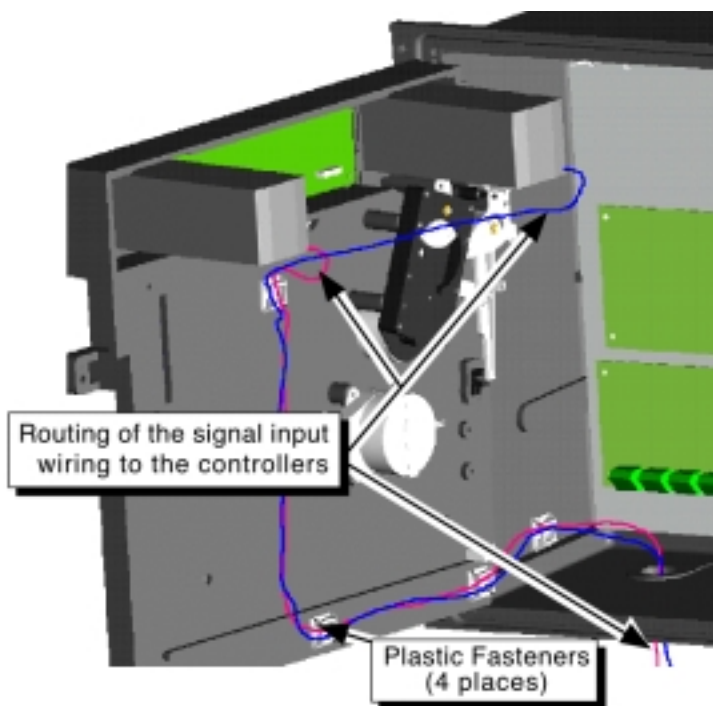

Figure 9.3.2b Controller signal input wiring routing

9.4 SPECIFICATION

Inputs

Range		± 100 mV and 0 - 10 V dc (auto ranging)
Sample rate		9 Hz (110 ms)
Calibration accuracy		0.25% of reading, ± 1 LSD, ± 1 °C/F
Resolution		< 1 μ V for 100 mV range, < 0.2 mV for 10 V dc range
Linearisation accuracy		$< 0.1\%$ of reading
Input filter		1.0 to 999.9 seconds
Zero offset		User adjustable over the full display range
Thermocouple	Types:	J, K, T, L, N, C, R, S, B & Platinell II
	Cold junction comp:	Automatic: typically > 30 to 1 rejection from 20 °C
RTD	Types:	Platinum 100, DIN std. 0.00385 $\Omega/\Omega/^{\circ}\text{C}$
	Excitation current:	0.2 mA
	Lead compensation:	Up to 22 Ω in each of 3 equal resistance leads
V, mV ranges		± 100 mV and 0 - 10 V dc (user configurable with these limits)

Outputs

Relay	Rating:	Min: 12V @ 100 mA, Max: 2 A @ 264 Vac resistive
Triac	Rating:	1 A resistive @ 264 Vac
Analog	Range:	Isolated, 0 to 20 mA configurable (load 600 Ω max.), 12 V dc limit

Control Functions

Control	Modes:	PID or PI with overshoot inhibition, PD, PI, P only or On/Off
	Auto/manual:	Bumpless transfer
	Setpoint rate limit:	0.01 to 99.99 degrees (or display units per minute)
	Cooling algorithms:	Linear, Water (non-linear), Fan (minimum on time), Oil, proportional only
Tuning	One-shot tune:	Automatic calculation of PID and overshoot inhibition parameters
	Automatic droop comp.:	Automatic calculation of manual reset value when using PD control
Alarms	Types:	Full scale high or low, Deviation high, low or band
	Modes:	Latching or non-latching, Normal or blocking action
		up to 4 process alarms can be combined onto a single output

General

Display		Dual, 4-digit x 7-segment high intensity LED
Dimensions & weight		48 mm W x 48 mm H x 103 mm D (1.89" x 1.89" x 4.06"); 250 g (8.82 oz)
Supply		100 to 240 Vac (-15%,+10%), 48 to 62 Hz, 10 Watts max.
Environmental	Temperature:	Operating: 0 to 40 °C (32 to 104 °F) (ambient with controller); Storage -10 to 70 °C
	Humidity:	5 to 90% RH (non condensing)
	Atmosphere:	Electrically conductive pollution must be excluded from the controller cabinet
	Altitude:	Not suitable for use above 2000 m (6,562 ft) or in corrosive or explosive areas
Panel sealing		IP65, NEMA 4X
Electromagnetic compatibility		BS EN50081 general emissions for industrial environments BS EN50082-2(95) standards for industrial environments
Safety standards		BS EN61010, installation category 2 (voltage transients not to exceed 2.5 kV)

10 CUSTOM LINEARISATION OPTION

10.1 INTRODUCTION

This option allows the user to enter a linearisation function of up to 32 points, which can then be used instead of the standard linearisations supplied with the recorder ('User' added to Lin Type list in Channel Range configuration).

The curve must be monotonic (i.e. it may have only one y value for each x value entered) and the x inputs must increase in value as they are entered. The points do not have to be equally spaced, so if the curve varies in gradient, more points can be entered round any 'knees', leaving the recorder to interpolate in areas where the gradient is more constant.

The curve is entered as pairs of points, one representing the input value which will be applied to the recorder (X), the other the output value (Y) which is to appear on the chart.

10.2 CONFIGURATION PAGES

The following set up shows how to enter a $y = x^3$ output function using inputs of -5 to +5.

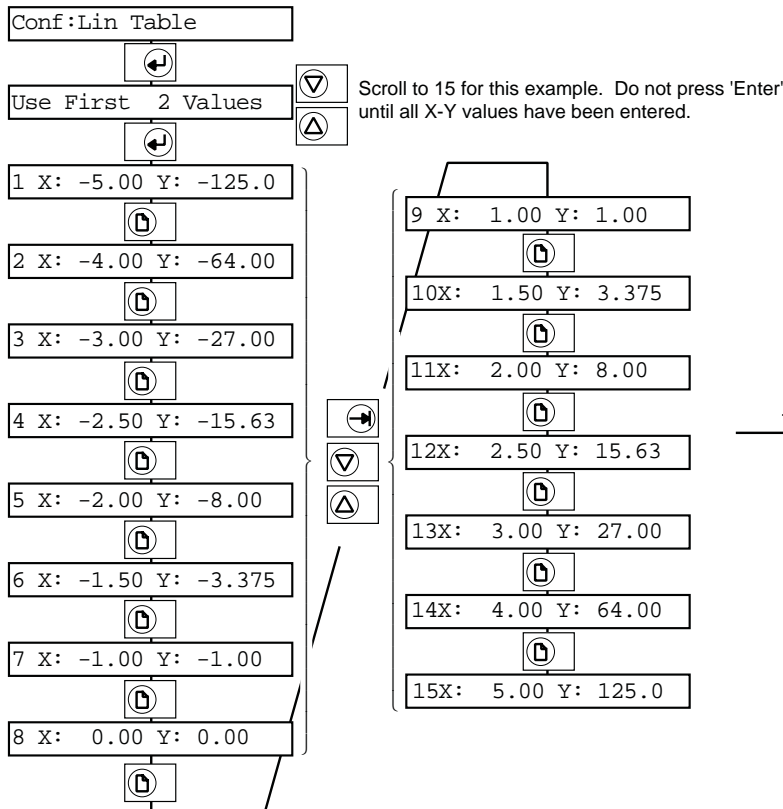

Figure 10.2a
Linearisation table configuration pages

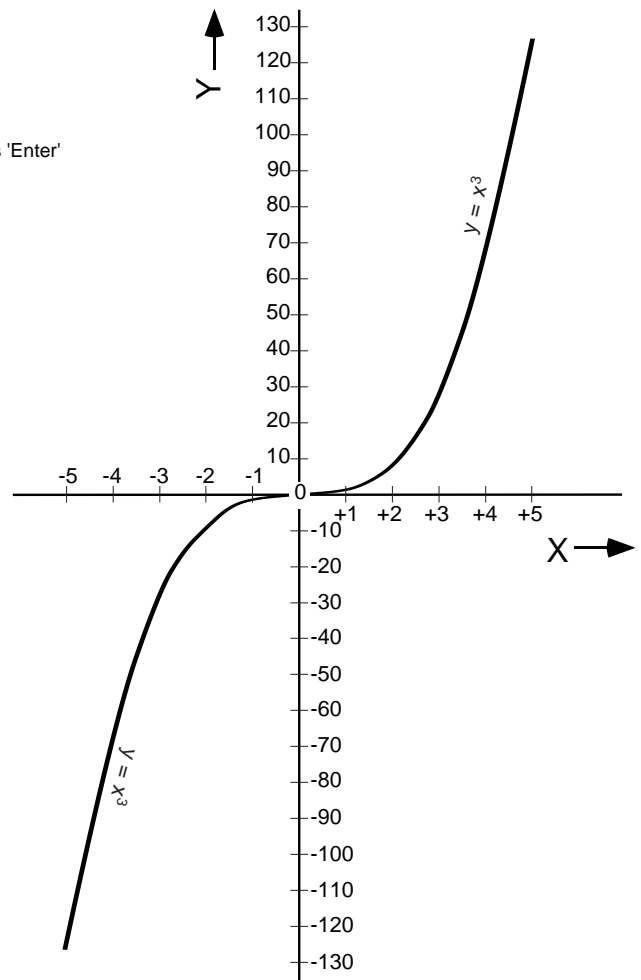

Figure 10.2b $y = x^3$ function

11 SERIAL COMMUNICATIONS OPTION

11.1 INTRODUCTION

This option provides the means for establishing an EIA422/EIA485 serial communications link with a host computer, using the Gould Modicon MODBUS protocol. The option comes on a single board (one of three option boards). For communication parameter (e.g. Baud rate) setting, see Section 11.3 below.

11.1.1 Safety isolation specification

Safety isolation (dc to 65Hz; BS EN61010)
 Installation category II; Pollution category 2 (see page 2 for definitions)
 Terminals to ground: 100 V RMS or dc (basic insulation)

11.2 WIRING

11.2.1 Pinout

Only one communications board may be mounted in any one of the three option positions. Figure 11.2.1 gives termination details for both connectors.

Note: The PU (pull up) output is 5V with a series 1000 Ω resistor.

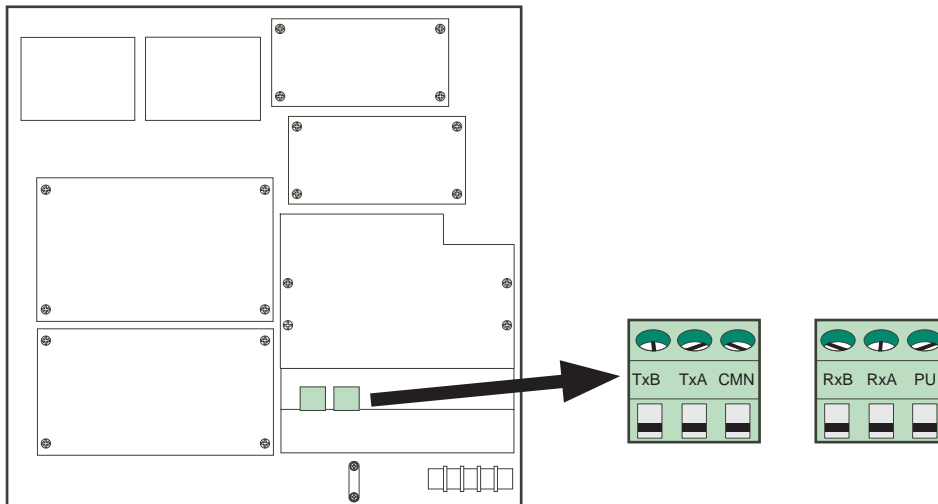

Figure 11.2.1 Communications option pinout

Communications terminal identifications vary, the following identifications are also used: TXA = (TX or TX+) and TXB = (TX or TX-); RxA = (RX or RX+) and RXB = (RX or RX-). Terminal "PU" is supplied by the "5 Volt" shown in Figure 11.2.2a and "CMN" is the "0 Volt" connection as well as the common connection for the transmit and receive lines. It should be connected to all instruments and to ground at a single point

11.2.2 Termination and Biasing

If the communications line is left open-ended, the end of the cable acts as a reflector, returning what can appear to be 'true' data signals back down the line. A receiver cannot distinguish between 'true' and reflected data, with the result that data is corrupted.

In order to avoid this, a termination resistor is fitted across the line at the final instrument. If the value of this resistor is equal to the characteristic impedance of the cable (120 Ohms in this case), then the line appears to be of infinite length and no reflections occur. Such a value however, does not give the best signal-to-noise ratio, so a compromise value (220 Ohms) is chosen to give the optimum performance in reducing unwanted reflections and in improving the signal-to-noise ratio.

The recorder communications port is terminated as shown in figure 11.2.2a, below. In a single point-to-point application, it may be necessary to terminate the instrument with a 220Ω resistor. In multi-drop systems, only the final unit should be terminated in this way, otherwise the transmitted signal levels may be reduced to an unacceptable level.

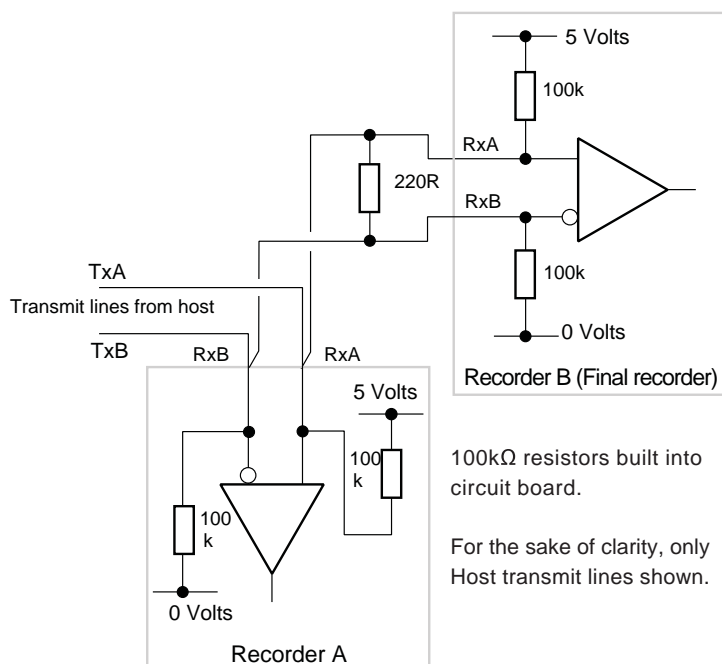

Figure 11.2.2a System termination and biasing

HOST COMPUTER

When not communicating, the instrument outputs go to a high-impedance state to allow multi-drop connection. This will cause a problem if the host computer is not fitted with biasing resistors to pull these essentially open circuit lines to their idle states as defined for the EIA422/EIA485 standards. To overcome such problems, external biasing resistors can be fitted as shown in figure 11.2.2b (a) below.

With long cable runs it may also be necessary to terminate the transmission line. Figure 11.2.2b (b) shows how this may be done using external biasing resistors. Such a circuit is for use where the host receiver does not have its own internal biasing arrangements. Where the host does have its own internal biasing, the fitting of a 220Ω resistor across the receive inputs (figure 11.2.2b (c)) will terminate the line correctly.

11.2.2 TERMINATION AND BIASING (Cont.)

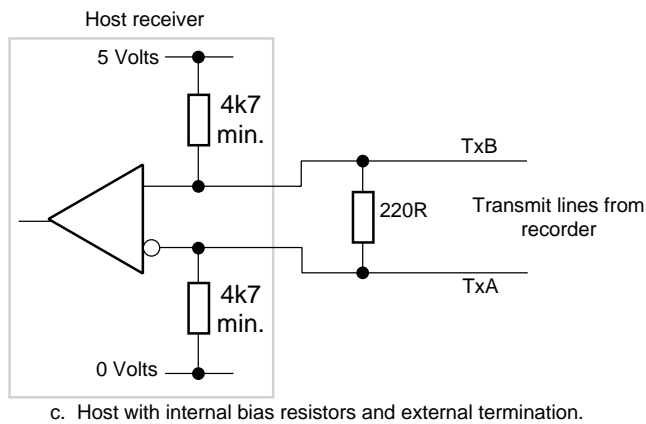
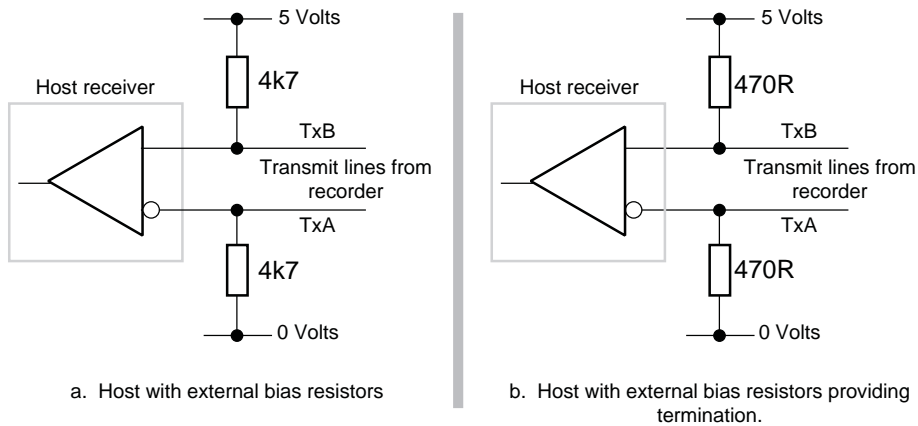

Figure 11.2.2b Host computer termination and biasing

11.3 CONFIGURATION PAGES

The configuration pages (figure 11.3) allow the Baud Rate, Parity, No^o of stop bits and the instrument address to be set up:

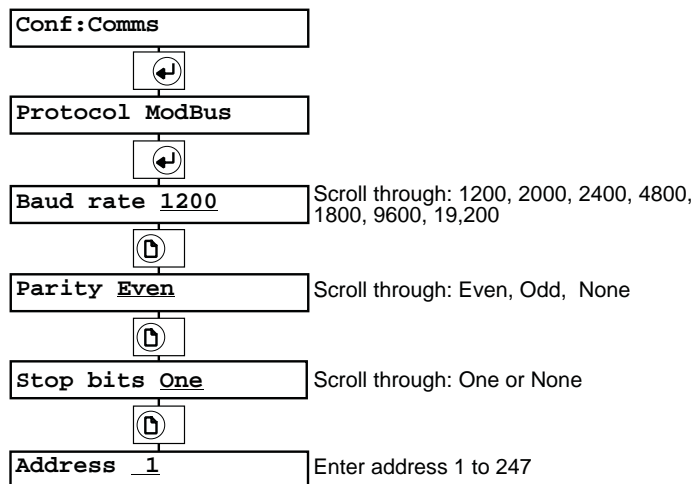

Figure 11.3 Configuration pages

11.4 GOULD MODICON MODBUS PROTOCOL

11.4.1 Introduction

When connected to a host computer the recorder acts as a slave Modbus device. The unit address (1 to 247) being set up as a part of the recorder's communications configuration. Only a limited number of function codes have been implemented (ref. Modbus protocol manual) and these are listed in section 11.4.4

11.4.2 Channel addressing

The channel 1 address listed in table 11.4.4 is the base address at which channel 1 may be accessed.

Note: Addressing starts at zero, whilst channel numbers start at 1

Example: to read a digital input at channel 4, the required address passed with the code 01 would be 03

If an alarm is set for an input or derived channel, the associated alarm parameters can be read using code 03

Example: To read the set point of absolute alarm 1 on channel 8, the required address passed with code 03 should be 1257 (1250 = channel 1; 1251 = channel 2 etc.).

The interpretation of alarm parameters (A1 to A4 and SP1 to SP4 in table 11.4.4) depends on alarm type as follow

ALARM TYPE	PARAMETER	DEFINITION
Absolute	A1 to A4	Not used
Absolute	SP1 to SP4	Setpoint values
Deviation	A1 to A4	Deviation Values
Deviation	SP1 to SP4	Setpoint values
Rate	A1 to A4	Rate value
Rate	SP1 to SP4	Period value (secs)
Digital	A1 to A4	Not used
Digital	SP1 to SP4	0000 = Open; FFFF = Closed

Table 11.4.2 Alarm parameter definition

Note: Any request to read a nonexistent setpoint value will result in the value 0000 being returned. This should not be taken to mean that the setpoint is at 0.000

11.4.3 Reading analog inputs

The values read are in the range 0000 to FFFF. To obtain the scaled relative value, the following calculation must be carried out where the analog input is in hex:

$$\text{Scaled value} = \left[\left(\frac{\text{High range} - \text{Low range}}{\text{FFFF}} \right) \times \text{Analogue input} \right] + \text{Low range}$$

In the event of a hardware error or under-range value, the value is forced to scale zero. Should the analog value be over range, the scaled value is forced to scale high.

11.4.4 Function codes

CODE	FUNCTION	RECORDER ACTION	CHANNEL 1 ADDRESS (DECIMAL)
01	Read coil status	Digital input state (true = >0.5)	0
02	Digital read input status	Digital input state (true = < 0.5)	0
		Input alarm 1 status	250
		Input alarm 2 status	500
		Input alarm 3 status	750
		Input alarm 4 status	1000
		Derived alarm 1 status	1250
		Derived alarm 2 status	1500
		Derived alarm 3 status	1750
		Derived alarm 4 status	2000
03	Read holding register	Analog input value	0
		Analog input A1 (Table 11.4.2)	250
		Analog input A2 (Table 11.4.2)	500
		Analog input A3 (Table 11.4.2)	750
		Analog input A4 (Table 11.4.2)	1000
		Analog input SP1 (Table 11.4.2)	1250
		Analog input SP2 (Table 11.4.2)	1500
		Analog input SP3 (Table 11.4.2)	1750
		Analog input SP4 (Table 11.4.2)	2000
		Derived channel A1 (Table 11.4.2)	2250
		Reserved (always returns 0000)	2500
		Derived channel A2 (Table 11.4.2)	2750
		Reserved (always returns 0000)	3000
		Derived channel A3 (Table 11.4.2)	3250
		Reserved (always returns 0000)	3500
		Derived channel A4 (Table 11.4.2)	3750
		Reserved (always returns 0000)	4000
		Derived channel SP1 (Table 11.4.2)	4250
		Reserved (always returns 0000)	4500
		Derived channel SP2 (Table 11.4.2)	4750
		Reserved (always returns 0000)	5000
		Derived channel SP3 (Table 11.4.2)	5250
		Reserved (always returns 0000)	5500
		Derived channel SP4 (Table 11.4.2)	5750
		Reserved (always returns 0000)	6000
		Input channel status (read only) (flags - see code 04)	6250
		Derived channel status (read only) (flags - see code 04)	6500
		Instrument status (read only) (flags - see code 07)	6750
		Print mode	7000
		0 = Trace priority	
		1 = Text priority	
		2 = Text only	

Table 11.4.4 Modbus implementation channel addresses (Sheet 1: codes 01 to 03)

11.4.4 FUNCTION CODES (Cont.)

CODE	FUNCTION	RECORDER ACTION	CHANNEL 1 ADDRESS (DECIMAL)
04	Read input register	Analog input value	0
		Input channel status	250
		No bits set: Channel OK	
		Bit 0 set: Channel off	
		Bit 1 set: Over range	
		Bit 2 set: Under range	
		Bit 3 set: Hardware error / bad PV	
		Bit 4 set: Ranging error / no data	
		Bit 5 set: Overflow	
		Bits 6 to 15: Always 0.	
		Derived channel value	500
		Reserved (returns 0000)	750
		Derived channel status	1000
		(Bits 0 to 15 as for Input channel status above)	
		Instrument status (flags - code 7)	1250
05	Force single coil	Sets digital input state for comms channel	0
		0 = 0.000; 1 = 1.000	
06	Preset single register	Preset holding register	As code 03
		(Presets values for comms channels only)	
07	Read exception status	Read instrument status	
		Bit 0: System error	
		Bit 1: Writing system failure	
		Bits 2 to 7 Always 0	
08	Loopback test	Diagnostic code 0 (Echoes message as sent)	
15	Force multiple coil	Sets digital input code for comms channels in	0
		address range. 0 = 0.000; 1 = 1.000	
16	Preset multiple registers	Preset holding register for each channel in	As code 03
		address range.	
		(Presets values for comms channels only)	
16	Print text string	In addition to the above code 16.	7250
		Data quantity is the total number of characters in the text string (including colour commands) divided by two (must have an even number of characters).	
		The text string must consist of no more than 39 characters and may contain no more than 10 colour commands of the form !n, where n is a numeric character from 1 to 6 as shown in the table below. Text is printed in black unless otherwise commanded. The '!' character may not be used as a text character.	
		MSB is printed first.	

n	Colour
1	Red
2	Green
3	Green
4	Blue
5	Blue
6	Black

Table 11.4.4 Modbus implementation channel addresses (Sheet 2)

11.4.4 FUNCTION CODES (Cont.)

65	Enter XMODEM mode	Holds 1 byte of data specifying which mode to enter 0 = standby; 1 = Receiver; 2 = Sender
66	Report XMODEM error	Returns 1 byte of data as follows: 0: Transfer OK - no errors 1: Restore failed completely File was incompatible or comms failed to transfer the file, Original configuration unchanged. 2: Restore failed on data. Some records ignored, but transfer mostly successful. 3: Restore failed on transfer Some config. transferred before failure. New configuration undefined 16: Save had no reply from comms and timed out 32: Save failed before transfer completed
EXCEPTION RESPONSES		
01	Illegal function	Unsupported or illegal Modbus function 0
02	Illegal data address	Data address out of range for instrument config 0 Attempt to preset input value of non comms channel Invalid configuration data
03	Illegal data	Data value out of range for function
06	Illegal busy	Configuration transfer in progress via another port so unable to action function

Table 11.4.4 Modbus implementation channel addresses (Sheet 3)

11.5 XMODEM TRANSFER

XMODEM transfers take place between a host computer and a single instrument to save or restore configuration.

The transfer procedure is as follows

1. Place any other instruments on the communications link into standby mode.
2. Set the required recorder to sender or receiver mode as appropriate.
3. Send or receive file at host.
4. 10 seconds after completion, host communications is restored to normal use.

Note: 10 seconds of inactivity on the communications link, at any point in the procedure, will cause the host communications to return to normal use for instruments in standby mode.

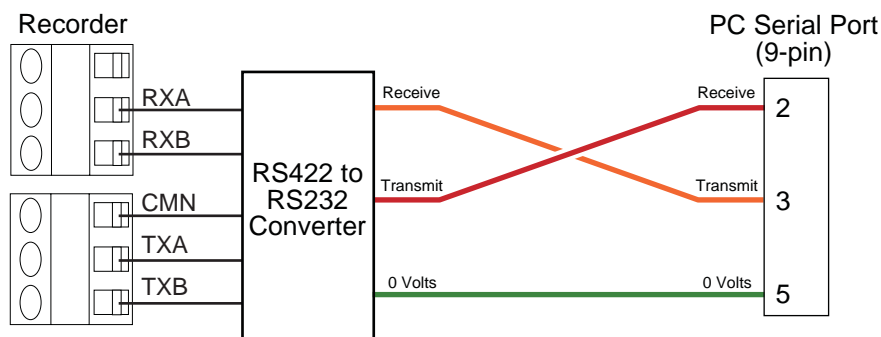

Figure 11.5 Recorder to PC wiring for transfer using configuration program

12 MEMORY CARD OPTION

12.1 INTRODUCTION

Note: Most of the memory card functions are not accessible to the operator until they have been enabled in the Memory Card Operator Access' configuration as described in section 12.5.

The memory card is a static RAM (Random Access Memory) with battery back-up. The battery, located within the card, maintains the data for a period which is dependent on card type. The instructions supplied with the card give details of storage periods and battery changing.

Files are stored in DOS format, and the card is PCMCIA version 2 compatible. Configuration software, available from the manufacturer, to run on a PC, can be used in conjunction with the card (and a suitable reader) to create or modify configurations for subsequent down loading to the recorder.

Memory card functions are all available both from the configuration menu and from the operator menu (unless access permission has been denied - see section 12.5). The major functions of the Memory Card options are:

Save and restore option:	Configuration save and restore.
ASCII log option:	As above Save and Restore option but with ASCII Data logging.
Compressed log option:	As ASCII log but with PACKED data format.

Reformatting software is included with PACKED format data to convert logs to ASCII format thus allowing manipulation of the data in PCs.

12.2 MEMORY CARD INSERTION

As shown in figure 12.2a, the memory card is inserted into a slot located at the top right corner of the chart platen. To insert the card, open the recorder door. Note that the instructions on the card "insert this edge" and "this side up" should be on the **right** side of the card as it is inserted. Push the card fully into the slot until the ejector button below the card slot moves out.

To remove the card, operate the card ejector button (shown below).

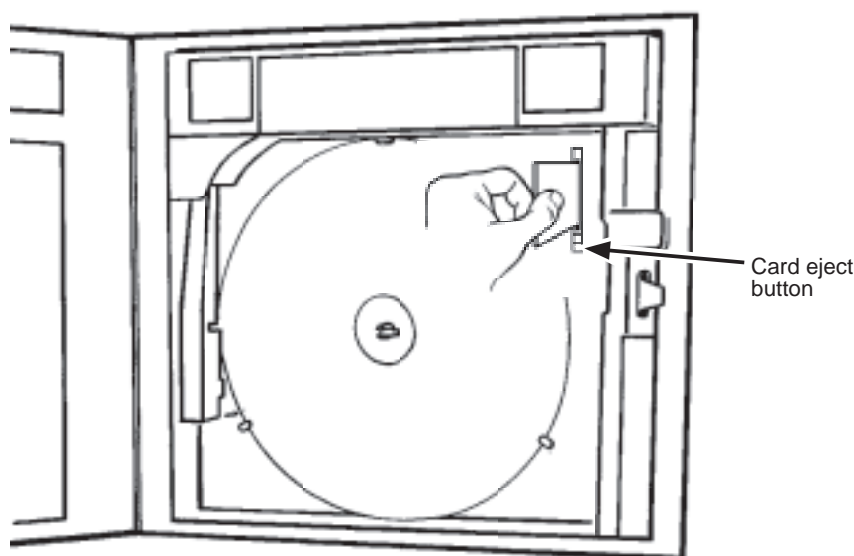

Figure 12.2a Memory card insertion

12 MEMORY CARD (Cont.)

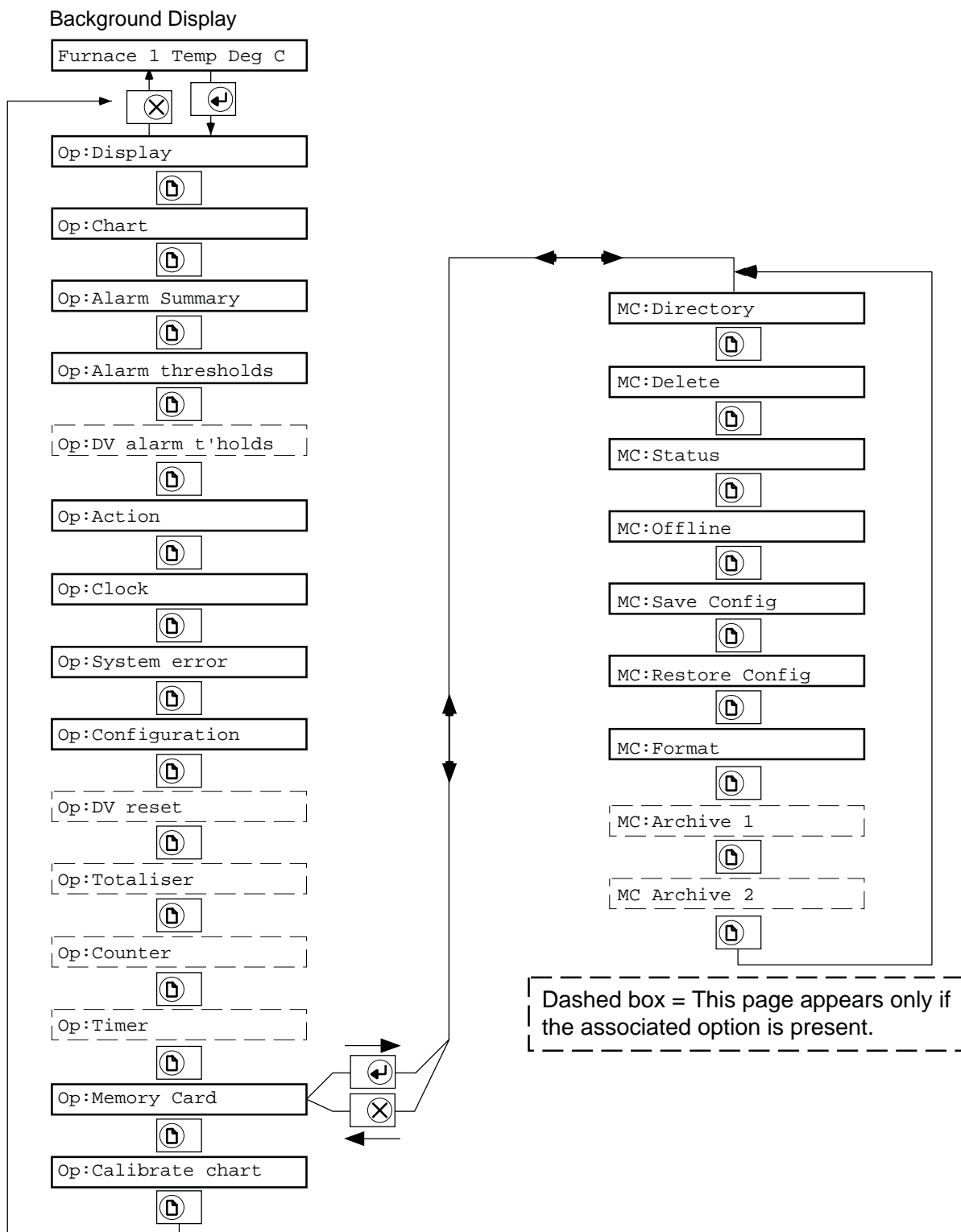

Figure 12.2b Memory card operator menu structure

12.2.1 Card formatting

Memory cards are tested prior to shipment and the battery removed to preserve its useful life. Before a memory card can be put into service, the battery must be installed following the instructions with the card. It then must be formatted by operating the 'Enter' key in the '↓ to FORMAT' display page as shown in figure 12.2.1 below.

Note: Any existing data on a card with a battery will be lost during format..

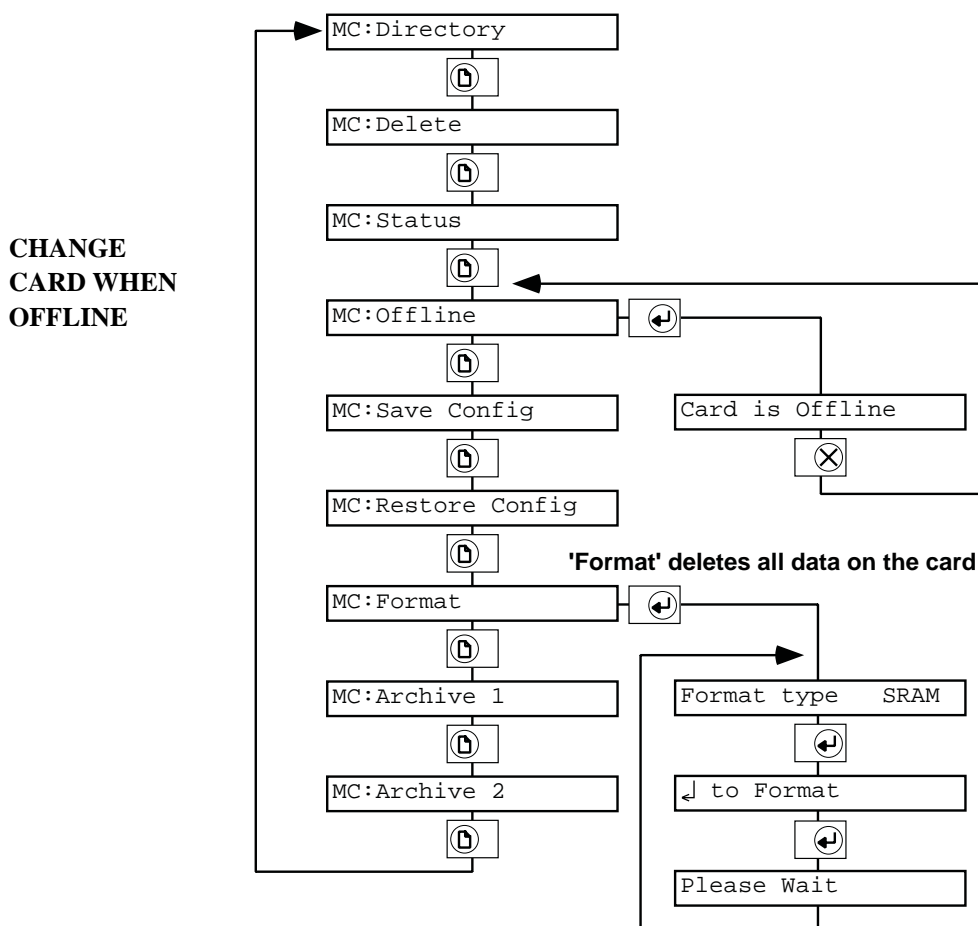

Figure 12.2.1 Card format and off-line menus

12.2.2 Changing cards

CAUTION

Before inserting or removing a PC card, MC:Offline should be selected (see figure 12.2.1 above). This ensures that data is not lost or corrupted whilst the card is inserted or removed. The card returns to the 'On-line' state as soon as the 'Card is Offline' display is quitted (by using the 'Cancel' key).

12.3 CONFIGURATION SAVE AND RESTORE

12.3.1 Save

Operation of the 'Enter' key from the Save Config page, calls a Filename page which allows the entry of an 8-character (max) string as the Configuration's file name. The file extension ".CFG" cannot be changed.

Once the file name has been entered, a further operation of the 'Enter' key causes the configuration to be written to the memory card.

Should the filename already exist, an overwrite confirmation is requested. 'Enter' confirms overwrite, or Cancel returns to the filename page.

See section 12.7.1 for details of permitted file name characters (Only DOS format file names allowed).

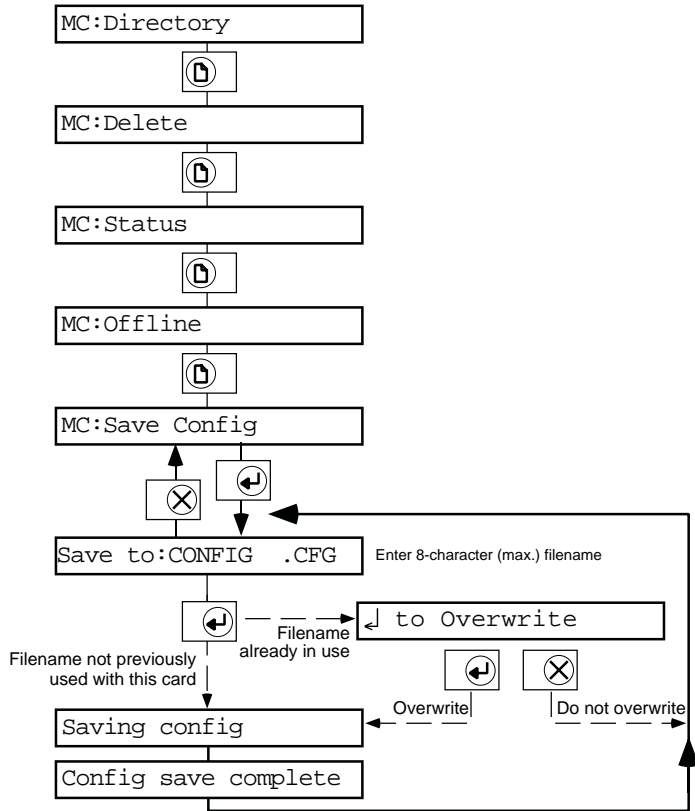

Figure 12.3.1

12.3.2 Restore

NOTE: All existing configuration information will be overwritten by the new configuration.

Operation of the 'Enter' key from the Restore Config page, calls the filename page. This allows the names of all the files held on the card to be scrolled through using the down arrow key. Configuration files can be identified as they have .CFG as their extension

Once the required file name is displayed, a further operation of the 'Enter' key causes the configuration to be read from the memory card.

While the configuration is being read from the memory card, the message 'Restoring config.' is displayed.

Once the configuration read is complete, operation of the Clear (X) key causes the recorder to re-initialize and return to background display.

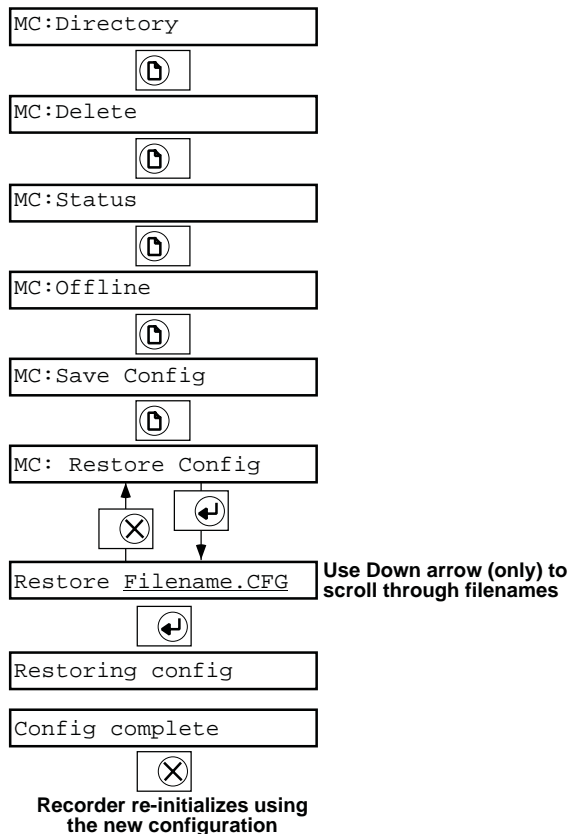

Figure 12.3.2

12.4 DATA LOGGING (ARCHIVE)

A log is a "snapshot" of the values within the log group at one point in time. Log files may contain one or a large number of single logs.

12.4.1 Archive Configuration

Logging to a data card file can be initiated by job, through operator action or, for log group 2, automatically at one of two configurable periods (archive intervals A and B). Under normal circumstances, interval A is used, interval B being selected by job action. More details can be found in section 4.1.4.

When archiving automatically, log group 2 is sent to the file defined in Archive 2 configuration (see section 12.4.1). The log interval and starting point can be set (i.e. if an interval is entered as "01:00:00" at 8:27, logging will start on the next full hour and log each hour thereafter (e.g. 9:00, 10:00, 11:00, etc).

The content of logs 1 and 2 are set up in Group Configuration as described in Section 4.6.

According to which of the archiving options is chosen, data can be logged in ASCII format or in PACKED format which is a compressed format for high density data archiving. Reformatting Software for running on a PC, is included with the packed data option to allow conversion of the compressed data into ASCII comma-delimited format, suitable for direct use with PC spreadsheet or word processing packages.

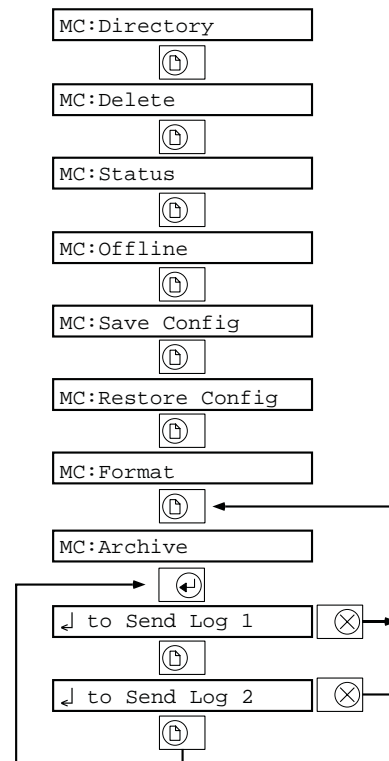

Figure 12.4.1 Operator Log initiation

Note: See section 12.7 for details of permissible file names / types.

The Archiving operator pages (figure 12.4) allow only the initiation of the log. Entry of file names, archive interval, data type etc., is carried out using the configuration menus (figure 12.4.1).

<p>File containing two input channels (2 and 3) including tags (TempVes1 and PressVes1) and units (°C and bar respectively), with DD/MM/YY,HH:MM:SS date format. Column headers (Channel tags) included:</p> <pre> "XXXXA" , , "2" , "3" "DD/MM/YY" , "HH:MM:SS" , " °C" , "Bar" "Log" , , "TempVes1" , "PresVes1" 29/02/96 , 12:15:06 , 28.93 , 0.989 29/02/96 , 12:16:04 , 28.71 , 0.963 </pre> <p>(Where XXXXA is the recorder model number)</p>	<p>File containing two input channels (1 and 3) NOT including tags or units, with DD/MM/YY,HH:MM:SS date format. Column headers (Channel tags) included:</p> <pre> "XXXXA" , , "1" , "3" , , "Log" , , 29/02/96 , 12:15:06 , 28.93 , 0.989 29/02/96 , 12:15:06 , 28.71 , 0.963 </pre> <p>(Where XXXXA is the recorder model number)</p>
---	---

Table 12.4.1 Examples of ASCII format files

12.4.1 ARCHIVE CONFIGURATION (Cont.)

With reference to menus in figure 12.4.1 following, and table 12.4.2, below, these configuration steps are possible:

File type	ASCII	Produces comma delimited columns of data. File name extension is .ASC (See table 12.4.1 above for examples)
	PACKED	Proprietary format. Data is stored in a compressed manner which requires reformatting software to extract data from it. File name extension is .PKD
File name type	Text	Fixed file name - see section 12.7.1.
	Hourly	New file opened hourly - see section 12.7.2.
	Daily	New file opened daily - see section 12.7.3.
	Counter	File name takes counter value - see section 12.7.4.
Include column titles	Yes/No	For ASCII files only. If YES, comma delimited column titles are sent depending on the 'Channel tag' and 'Instrument tag' fields in the Log Format Configuration described in section 4.6.1.
Date format (ASCII)	DD/MM/YY,HH:MM:SS	First two columns used to specify time and date of archive. (DD/MM/YY might be MM/DD/YY according to the date format selected in Clock configuration.
	Spreadsheet	Single, floating-point number. The integer part is the number of days since 31st Dec 1899, the decimal part is the proportion of the day since midnight. For example, Noon on the 1st Jan 1900 would be represented by a value of 1.5, while a value of 34121.25 would represent the 6 am on the 1st June 1993.
	Integer	Compresses time and date as YYMMDDHHMMSS, so that 6 am on the 1st June 1993 would be represented as 930601060000.
Compression ratio	Normal	For PACKED data only, compresses the data, but provides an exact copy.
	High	For PACKED data only, compresses the data more than NORMAL. Input channel values are saved to 0.02% accuracy, Totalisers, counters and derived channels are saved to 0.000004% of display accuracy (4 parts in 10 ⁸)

Table 12.4.2

JOBS

If an archiving option is present, the following jobs are added to the list given in section 4.1.5:

- Log 1 to archive 1
- Log 2 to archive 2
- Archive interval B
- Message (Msg) N to archive 1
- Message (Msg) N to archive 2

All the above can be initiated 'On going active', 'On going inactive' or 'On acknowledge'

12.4.1 ARCHIVE CONFIGURATION (Cont.)

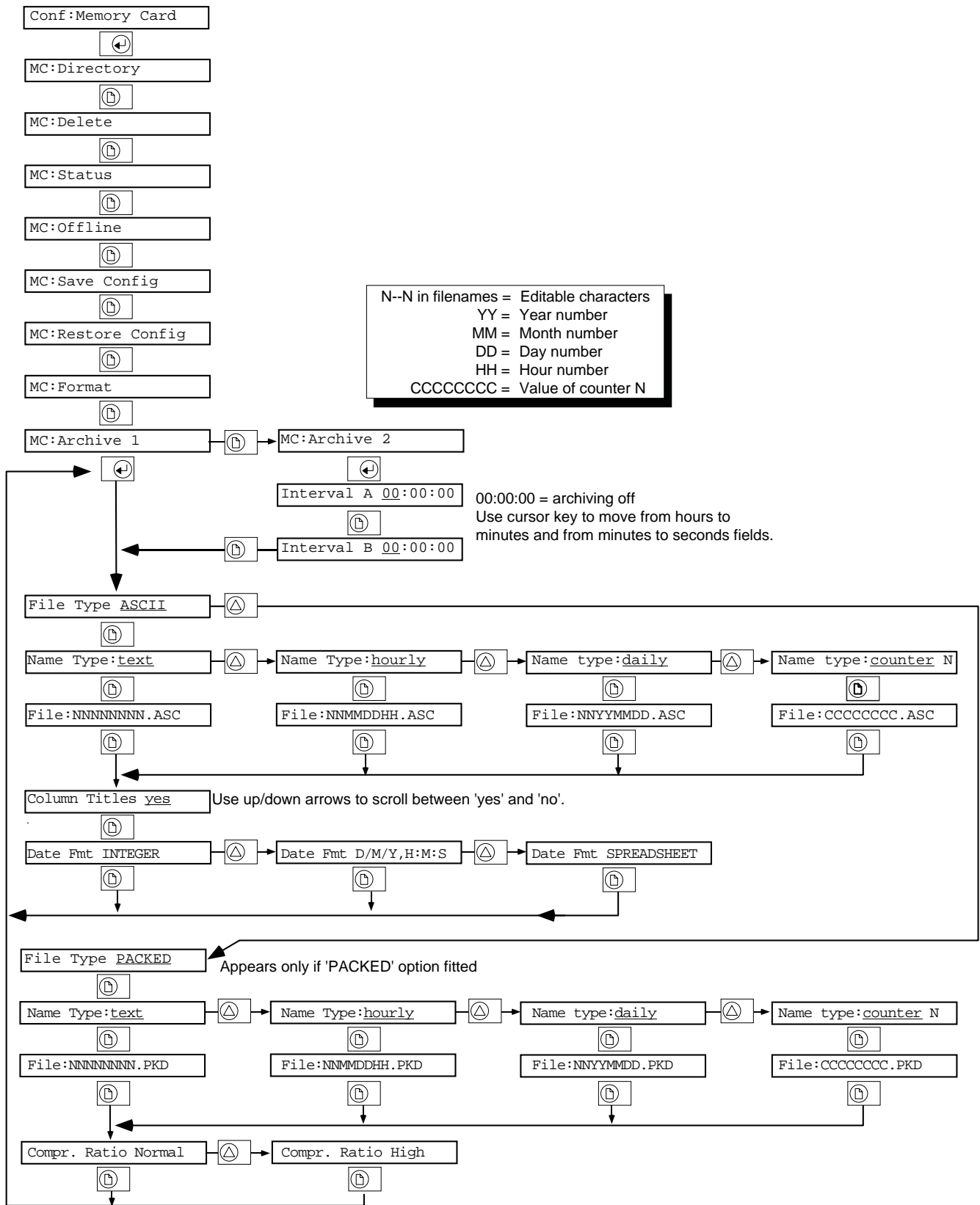

Figure 12.4.2 Archiving configuration menus

12.4.2 Archive interval

In 'Archive 2' configuration page, use the cursor and numeric entry keys to enter the required archive intervals A and B for automatic logging of log 2 group. An entry of 00:00:00 causes the automatic triggering to be inhibited. Automatic archiving is carried out at interval A except when interval B is selected by job action.

If a 'round figure' value (e.g. 00:10:00 for 10 mins, 01:00:00 for 1 hr.) is entered at 9:03AM, the recorder will start its automatic archiving at the next whole 10-minutes or the next whole hour (e.g. 9:10AM, or 10:00AM).

12.5 OPERATOR ACCESS

For the sake of security, each of the memory card functions can be added to or removed from the operator pages using the OPERATOR ACCESS part of the recorder configuration. Refer to the Operator Access description in section 4.13 for further details. If all functions are removed, M CARD does not appear in the Operator Menu.

The up/down arrow keys are used to toggle the permissions between 'yes' and 'no'.

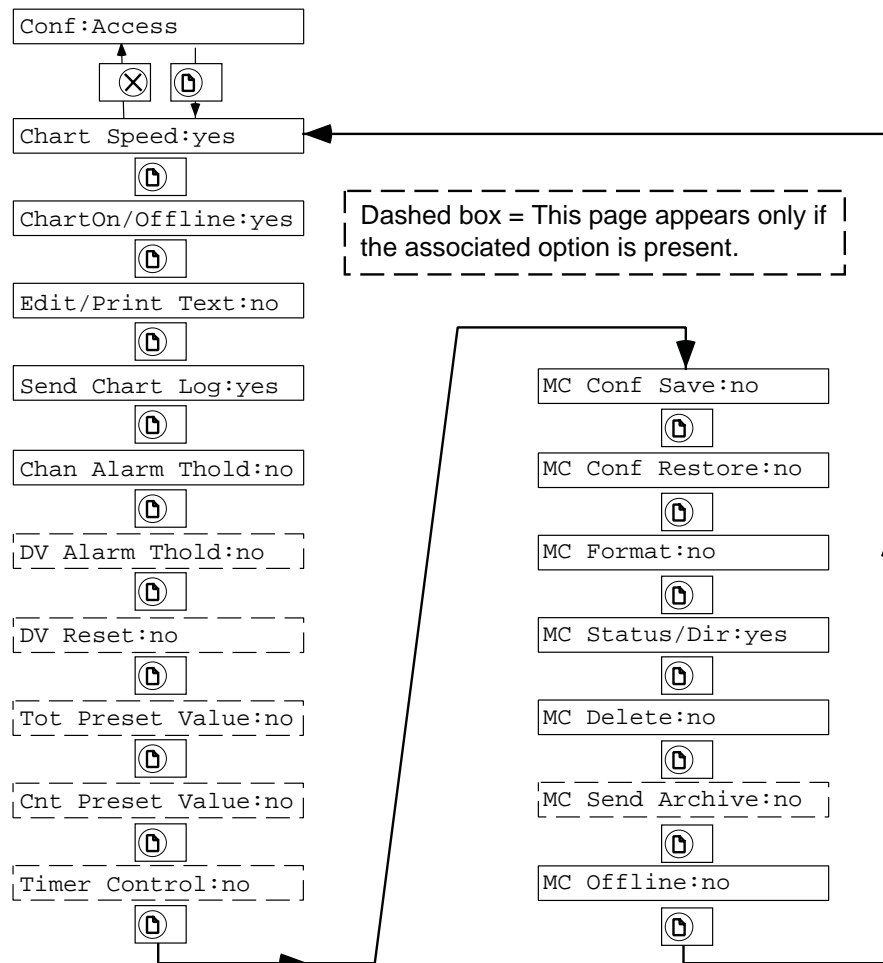

Figure 12.5 Operator permissions

12.6 MEMORY CARD GENERAL FUNCTIONS

12.6.1 Directory

The display shows the name of the oldest file on the card, together with its size in Bytes. As shown in figure 12.6.1, the down arrow key allows the user to scroll through the file names held in the card memory. For each filename on display, operation of the page key calls a further display page which shows the time and date of the file's last activity.

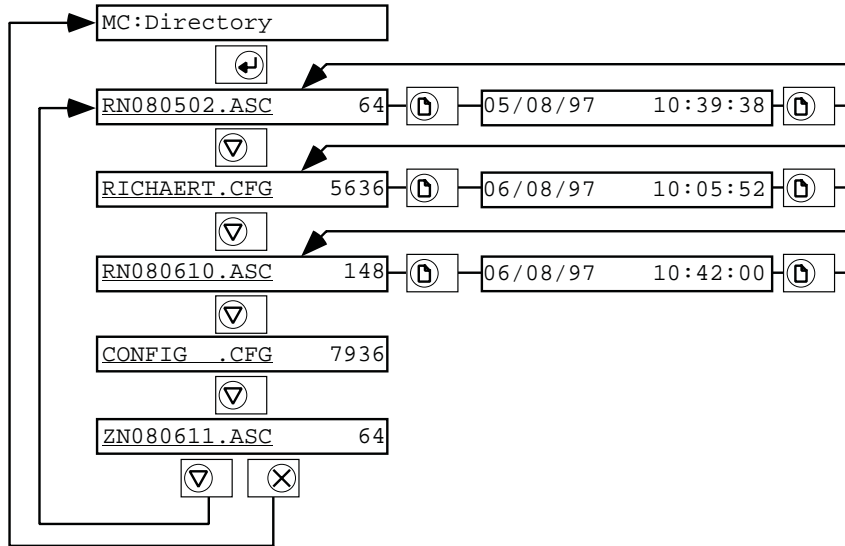

Figure 12.6.1 Directory function display pages

12.6.2 Delete

As shown in figure 12.6.2, the display shows the name of the oldest file on the card, together with a '↓ to erase' statement. The down arrow key allows the user to scroll through the file names held in the card memory. For each filename on display, operation of the 'Enter' key calls a further display page which asks for confirmation of erasure. A further operation of the 'Enter' key removes the file from the directory.

Operation of the Page key from any of the filename pages, allows the file size, and data and time of last activity to be viewed as shown in the figure.

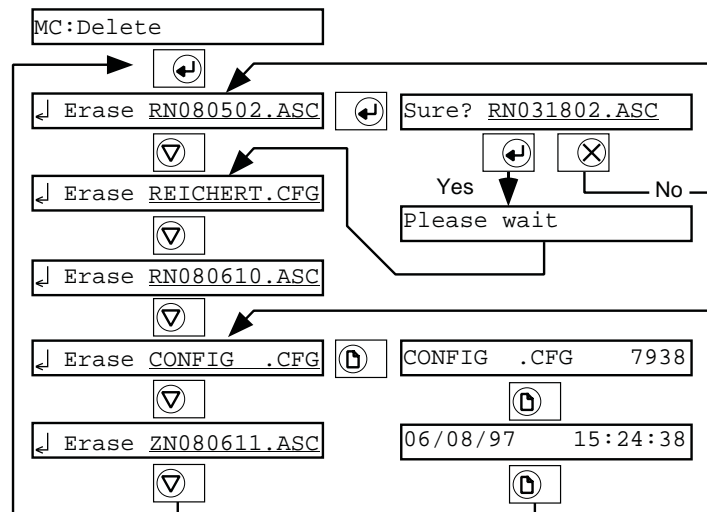

Figure 12.6.2 Delete function display pages

12.6.3 Card status

This display tells the user how much memory is currently used (11kB in the example) out of the card's total memory (128kB in the example).

Operation of the page key calls a display which shows whether the card is write protected or not.

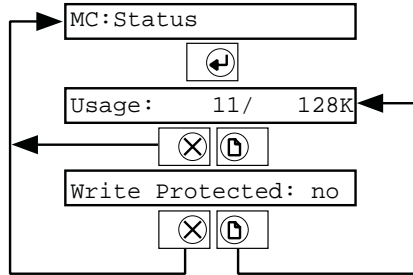

Figure 12.6.3 Status display pages

Note: A newly formatted card uses some space for format data,

12.6.4 Automatic file deletion

Should the card become full while chart copy or data logging / archiving activities are being carried out, the oldest data logging / archiving file on the card is deleted. (The oldest file will be deleted whether or not it is of the same type as the one being written.) **Existing configuration files (.CFG) are not deleted.**

Should the card become full while a Configuration Save is being attempted the Save will be aborted and the message 'Err:Card full' will be displayed until cleared by the 'Clear' (X) key.

12.7 ARCHIVE FILES

As shown in figure 12.7 for 'Archive 1', the following types of file name may be used when archiving data.

1. Text
2. Daily (Uses the recorder's real-time clock)
3. Hourly (Uses the recorder's real-time clock)
4. Counter value.

The file names consist of up to eight characters, followed by a three-character non-editable extension.

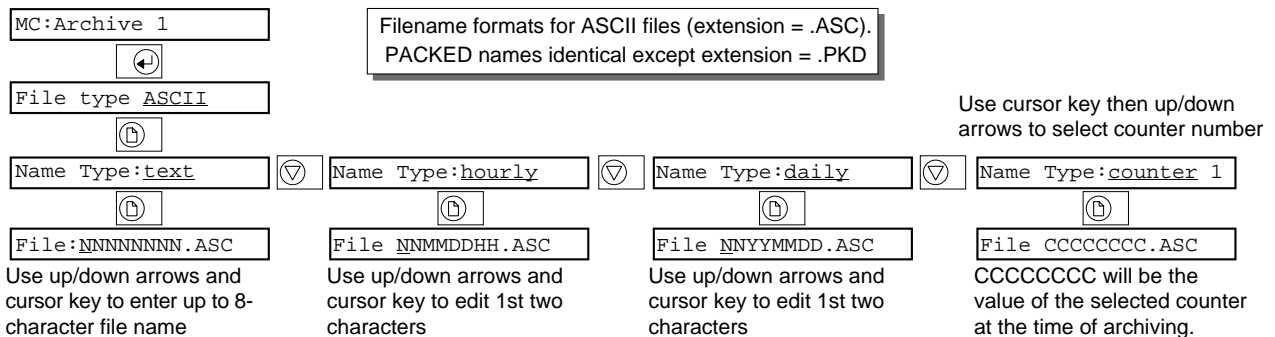

Figure 12.7 Filename selection

12.7.1 Text file names

With 'Filename type' selected as 'Text', the NN—NN field can be freely edited with alphanumeric characters as follows:

A to Z, a to z, 0 to 9 à ê è ô ù # \$ % & () - _ ! ^ ' { } ~ â ë ì ï ò û ÿ á í ó ú

The use of any other character will result in a fleeting 'Invalid config' message.

12.7.2 Hourly file names

With 'Name Type' scrolled to 'Hourly', only the first two characters (NN) can be edited. The remainder of the file name will be the time and date on which the copy was initiated. Thus if an ASCII log were started some time between nine and ten a.m. on the 3rd of August, then the file name would be NN080309.ASC.

12.7.3 Daily file names

Daily filenames are similar to hourly filenames except that they contain the date rather than the time at which the file is opened. Only the first two characters (NN) can be edited; the remainder of the file name will be the date on which the file was initiated. Thus if an ASCII log were initiated some time on the 3rd of August 1998, then the file name would be NN980803.ASC.

12.7.4 Counter file names

With 'Filename type' scrolled to 'Counter', none of the filename characters can be edited; the file name being the value of counter N. This allows, for example, a separate chart copy to be made for individual batches, if counter N is set up to hold the batch number. Should the counter be incremented during data transfer, the file will be closed at an appropriate point, and a new file opened with the counter's new value for a file name.

12.7.5 File name extensions

All logging file names have automatic extensions of "ASC*" or "PKD*" depending on whether they are in ASCII or PACKED format (See section 12.4).

* If a new ASCII file is created on a disk that already has a XXXXXXXX.ASC file, then the extension is 'incremented' from ASC to AS1. If AS1 also exists, the extension will be incremented to AS2, AS3 — A10 — 100, and so on (up to 999), until an unused file name is found. PKD extensions are treated in exactly the same way.

Configuration file names (.CFG extensions) are different in that if an attempt is made to create a configuration file which already exists, a warning message appears asking for overwrite permission, and if this is given, the existing file will be overwritten and lost.

12.7.6 Rules for creation of files

1. The first log generated after the disc is placed online will force a new file to be created.
2. If an Hourly or Daily file name is chosen, the first log generated during that clock hour or calendar day will create a new file.
3. The first log generated after any change has been made to the Archive Menu will create a new file.
4. If a Counter name is chosen, the incrementing of the chosen counter will create a new file.
5. The first log generated after any change has been made to the configuration of any channel will create a new file.

If none of the above events occur, an automatic interval or timer job will add a new set of data to the open file.

12.8 OTHER INFORMATION

12.8.1 Event sources

The following event sources (depending on which option is fitted) are added to the recorder:

1. Mem Card Bat Low
2. Mem Card Full
3. M Card Near Full (80% full)
4. MCC Overdrive (Archiving buffer full and no card or available card space)

These can be used to initiate recorder jobs as described in section 4.1.5.

12.8.2 System errors

The following possible system errors are added to the recorder:

1. Memory card battery low
2. Memory card battery flat
3. MCC Overdrive error (Archiving buffer full) (Archiving options only)

Any of these will cause a message to be sent to the display and an entry to be placed in the system error list (see section 3.7).

12.8.3 Error messages

In the event of an error occurring during card use, a message will appear for a few seconds. The following error messages are possible, if all memory card options are present:

Directory empty	Card reader fault
Card write protected	Card read failure
Card changed	Card write failure
Card not formatted	Bad filename
Card not fitted	Card data corrupted
File write protected	Card full
File read protected	MCC overdrive

12.9 MEMORY CARD CONFIGURATION MENU OVERVIEW

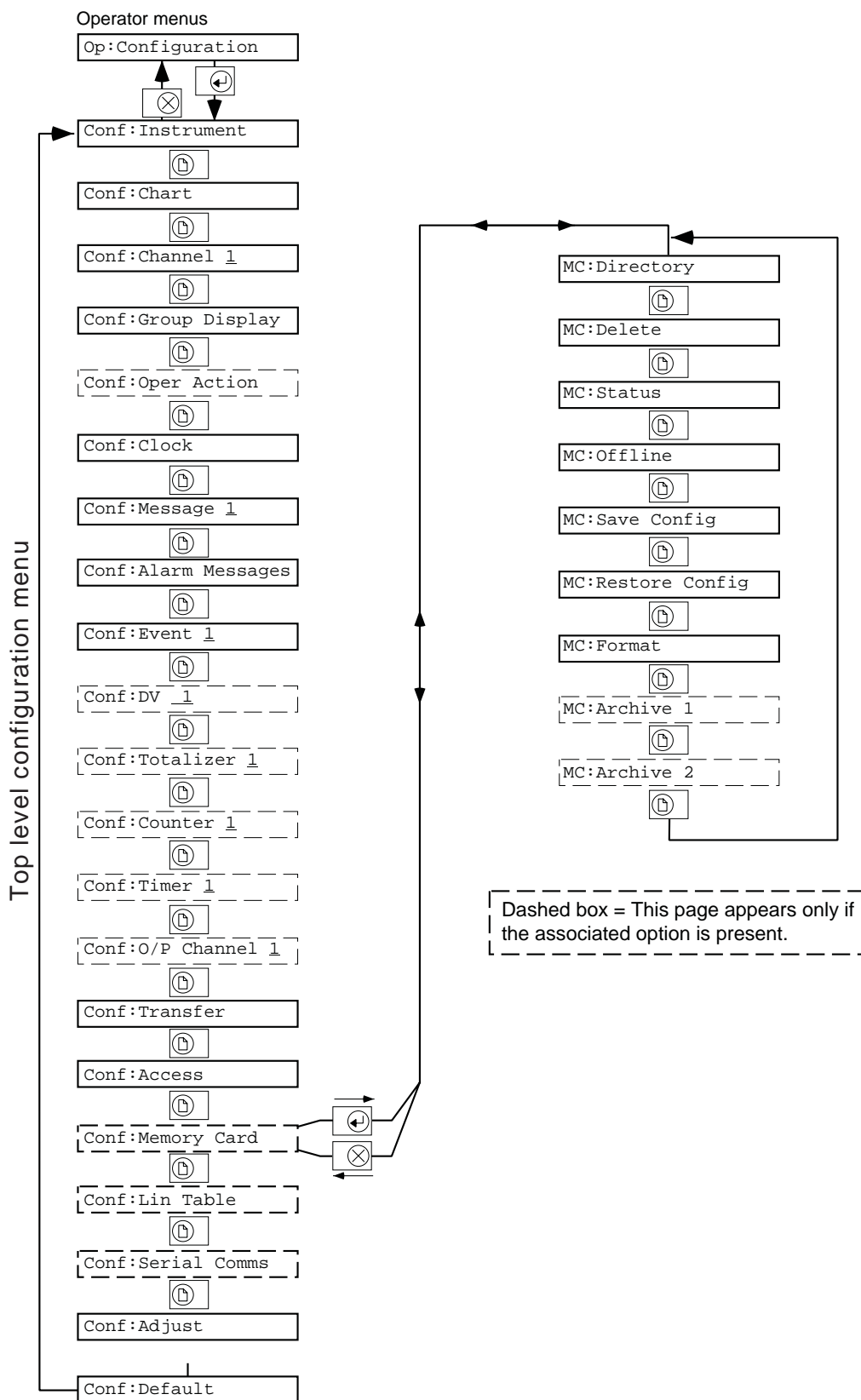

Figure 12.9 Memory card menu structure

13 TRANSMITTER POWER SUPPLY OPTION

13.1 INTRODUCTION

This option supplies one or two sets of three isolated 25 Volt outputs. Each output is intended to supply power to a remote transmitter in order to run a 0 to 20 mA or a 4 to 20 mA current loop.

Physically, each unit consists of a circuit board and associated channel input shunt assemblies located on the inside back wall of the case (see figure 1.2.2). Electrically, the circuit boards contain a transformer with multiple isolated secondary windings used to drive three simple regulators via individual rectifying/filtering circuits. Outputs from the regulators are wired to terminal blocks for user connection.

CAUTION

Although the recorder can operate on a line voltage of 90 to 264 Vac, the transmitter power supply must be set for the level of voltage connected. See the link identifications shown in Figure 13.1.

Figure 13.1 shows an overall view of a transmitter power supply option with inputs for three channels.

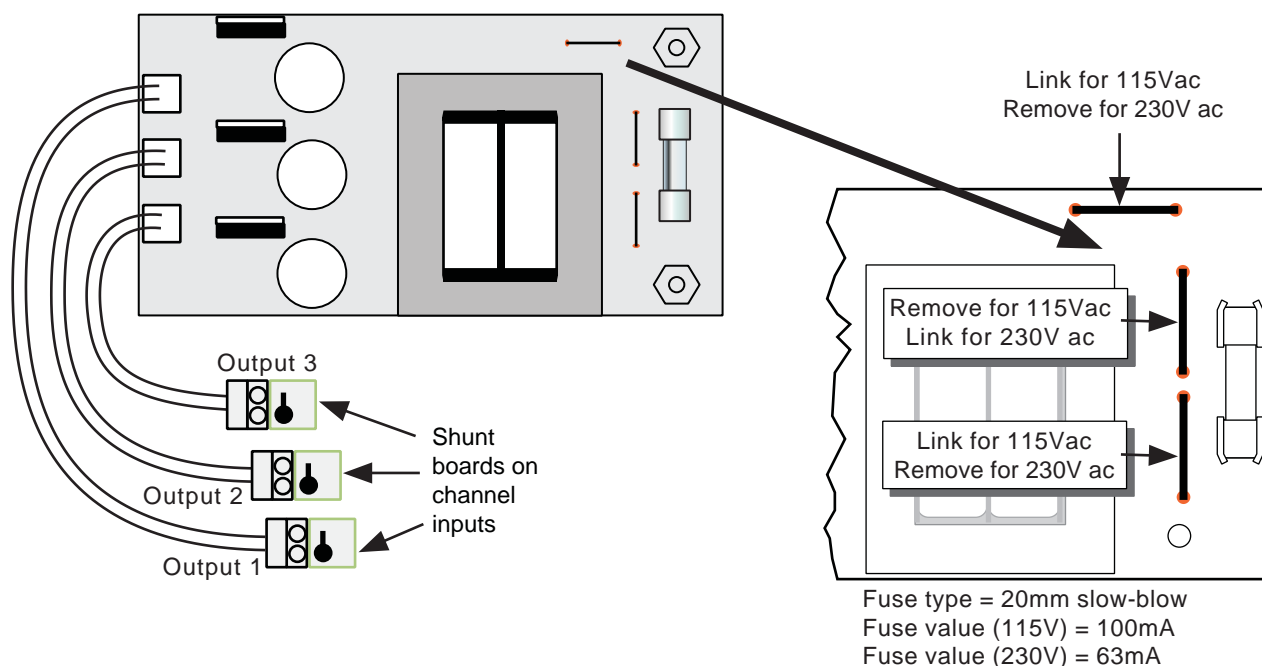

Figure 13.1 Transmitter power supply

13.1.1 Fuses

The required fuse value depends on the supply voltage, as shown in table 13.1.1. The fuse type is 20 mm slow-blow, and one is located under a insulating cover on each circuit board as shown in figure 13.1 above.

Supply Voltage	Fuse value	Fuse part Number
110/120	100 mA	CH050012
220/240	63 mA	CH050630

Table 13.1.1
Supply Voltage versus Fuse Values

13.1.2 Safety isolation specification

Safety isolation (dc to 65Hz; BS EN61010)	Installation category II; Pollution degree 2 (see page 2 for definitions)
Channel to channel:	100V RMS or dc (double insulation)
Channel to ground:	300V RMS or dc (basic insulation)

13.2 SIGNAL WIRING

The transmitter outputs are connected at a terminal block as shown below. Connection between the shunt board and the power supply are made at manufacture.

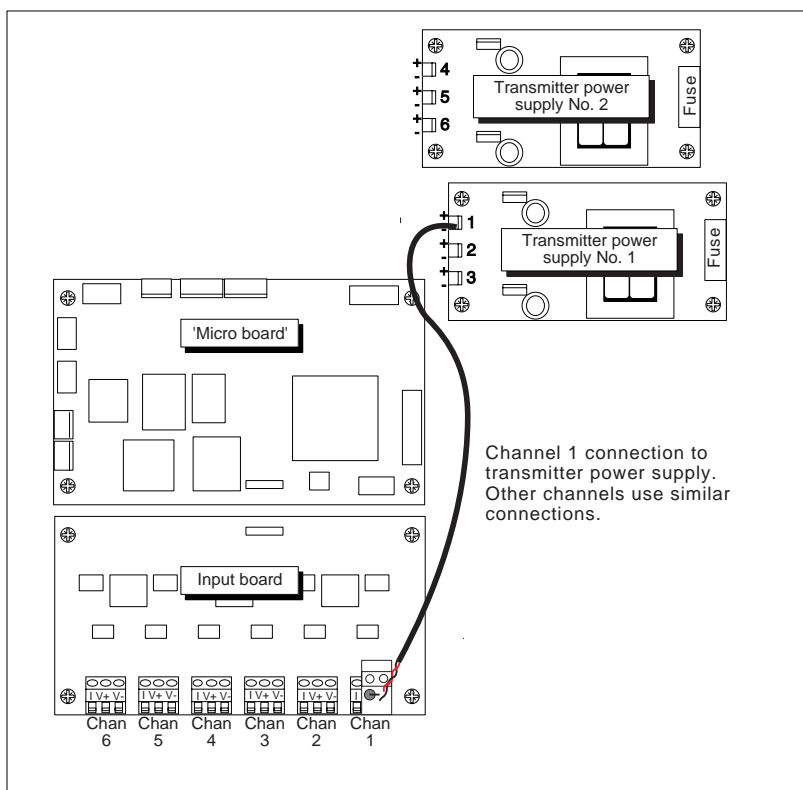

Figure 13.2a Internal Transmitter power supply wiring

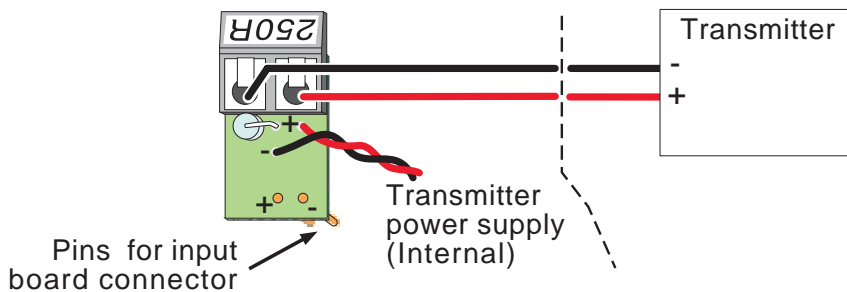

Figure 13.2b Transmitter wiring (internal power supply)

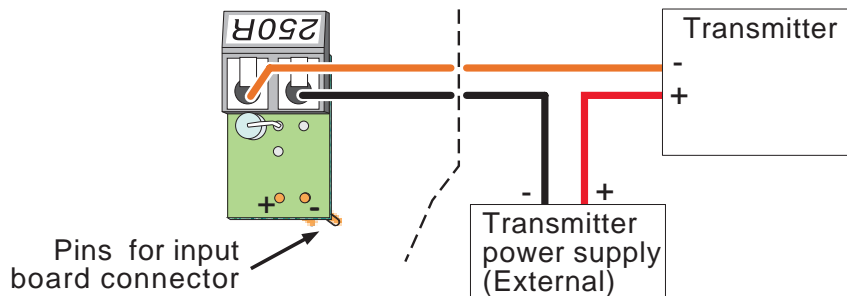

Figure 13.2c Transmitter wiring (external power supply)

This page is deliberately left blank

14 REFERENCE

14.1 COSHH

14.1.1 Printheads

Note: The COSHH data included here is derived directly from data sheets produced by the manufacturer to cover all its products. This is reflected in the fact that the lists of part numbers may include more than those items relevant to this product.

Product: WATER BASED INKS NOT CONTAINING FORMAMIDE			
Part numbers: LA248163 LA249556 LA250280			
HAZARDOUS INGREDIENTS			
Name	% Range	TLV	Toxicological data
Acid dye	1 to 4	Not available	Not established
PHYSICAL DATA			
Boiling point	>212 C	Specific gravity	1.05 to 1.1
Vapour pressure	<20 mm Hg	Solubility in water	Complete
Odour	None	Colours	Various
FIRE AND EXPLOSION DATA			
Flash point (deg C) (Method used)	Not flammable		FLAMMABLE LIMIT
Extinguishing media	Use medium appropriate to primary cause of fire.		LEL Not available UEL Not available
Special fire-fighting procedures	None		
Unusual fire and explosion hazards	None		
HEALTH HAZARD DATA			
Threshold limit value	Not established		
LD 50 Oral	> 5g/kg	LD 50 Dermal	Not established
Skin and eye irritation	None in normal use		
Over-exposure effects	Slight irritation of mucus membrane		
FIRST AID PROCEDURES			
Eyes and skin	Flush affected areas with water. If irritation develops, consult a physician.		
Ingestion	If swallowed, dilute with water. Induce vomiting. Obtain immediate medical attention		
Inhalation	If inhaled, move to fresh air. If necessary, aid breathing and obtain medical attention		
REACTIVITY DATA			
STABILITY			Conditions to avoid Strong oxidising agents and temperatures above 90 C
Stable	Yes	Unstable	
Hazardous decomposition products	None		
Hazardous polymerisation	Will not occur		
SPILL OR LEAK PROCEDURES			
Wipe up spills with towels and cloths. Remove stains with soap solution.			
Dispose of waste in accordance with local environment control regulations			
SPECIAL PROTECTION INFORMATION			
Respiratory	If vapours are generated, use organic vapour respirator		
Ventilation	Normal ventilation is adequate		
Protective clothing	Use gloves when handling printheads to avoid stains on skin/clothing		
Other	When printheads are being used for recording purposes, there are no known deleterious effects arising from the inks or pen tips.		

14.1.2 Batteries

Product: Rechargeable batteries			
Part numbers: PA250331			
HAZARDOUS INGREDIENTS			
Name	% Range	TLV	Toxicological data
Mischmetal alloy	10	Not available	
Nickel Hydroxide	10	Not available	Highly toxic if ingested
Potassium hydroxide	8	Not available	Highly toxic, Highly corrosive.
PHYSICAL DATA			
Boiling point	Not applicable	Specific gravity	Not applicable
Vapour pressure	Not applicable	Solubility in water	Not applicable
Odour	Not applicable	Colours	Not applicable
FIRE AND EXPLOSION DATA			
Flash point (deg C) (Method used)	Not applicable		FLAMMABLE LIMIT
Extinguishing media	Use medium appropriate to primary cause of fire		LEL Not applicable
			UEL Not applicable
Special fire-fighting procedures	Not applicable		
Unusual fire and explosion hazards	Batteries might explode due to excessive pressure build-up which might not be self-venting. Toxic fumes might be generated.		
HEALTH HAZARD DATA			
Threshold limit value	Not applicable		
LD 50 Oral	Not applicable	LD 50 Dermal	Not applicable
Skin and eye irritation	Should cells leak, the leak material will be a caustic solution. Avoid contact.		
Over-exposure effects	Not applicable		
Chemical nature	See above. There are no risks in normal use.		
FIRST AID PROCEDURES			
Eyes and skin	If leakage occurs, wash the affected area with plenty of water and cover with dry gauze. If eyes are affected, wash with plenty of water. Seek medical assistance.		
Ingestion	If ingestion of leak material occurs, DO NOT induce vomiting. Give plenty of milk to drink. Obtain immediate medical assistance, stating 'NiMH battery'. If battery ingested, seek medical assistance.		
Inhalation	Not applicable		
REACTIVITY DATA			
STABILITY		CONDITIONS TO AVOID	
Stable	Yes	Unstable	Mechanical damage, Overcharging Short circuiting terminals Charging temperatures outside the range 0 to 65 C
Hazardous decomposition products	None		
Hazardous polymerisation	Will not occur		
SPILL OR LEAK PROCEDURES			
In normal use there is no risk of leakage. If batteries are abused, this may lead to the leaking of a caustic alkaline solution which will corrode aluminium and copper. The leak material should be neutralised using a weak acidic solution such as vinegar, or washed away with copious amounts of water.			
Contact should be avoided			
DISPOSAL			
Batteries must be disposed of in accordance with current local regulations. Batteries should not be discarded with normal refuse.			
SPECIAL PROTECTION INFORMATION			
Respiratory	Not applicable		
Ventilation	Not applicable		
Protective clothing	Not applicable		
Other			

14.2 ERROR MESSAGES

14.2.1 Invalid configuration

This message can appear under a number of circumstances, but is normally the result of the operation of the 'Enter' key before configuration is complete. For example if you have set input type to T/C, but operate the Enter key before you set a suitable Linearization type, the message will appear, and the attempted 'Enter' will be ignored.

14.2.2 Failure to adjust channel (Adj fail on ch NN)

Appears during the input adjust procedure (section 4.13) if the channel is in error or if there is a hardware or internal communications fault.

14.2.3 Input adjust not available (I/P Adj n/a on ch NN)

Appears if an attempt is made to adjust an input channel which is not an analogue input.

14.2.4 Printer must be off line

Certain functions require that the chart be off line before they can take place. Op:Chart must be accessed, and the chart drive switched off.

14.3 LIST OF EFFECTIVE PAGES

This (issue 6) manual consists of the following pages at their stated issue number and date

Page 1	Issue 7 Nov 06	Page 46	Issue 7 Nov 06	Page 91	Issue 7 Nov 06
Page 2	Issue 7 Nov 06	Page 47	Issue 7 Nov 06	Page 92	Issue 7 Nov 06
Page 3	Issue 7 Nov 06	Page 48	Issue 7 Nov 06	Page 93	Issue 7 Nov 06
Page 4	Issue 7 Nov 06	Page 49	Issue 7 Nov 06	Page 94	Issue 7 Nov 06
Page 5	Issue 7 Nov 06	Page 50	Issue 7 Nov 06	Page 95	Issue 7 Nov 06
Page 6	Issue 7 Nov 06	Page 51	Issue 7 Nov 06	Page 96	Issue 7 Nov 06
Page 7	Issue 7 Nov 06	Page 52	Issue 7 Nov 06	Page 97	Issue 7 Nov 06
Page 8	Issue 7 Nov 06	Page 53	Issue 7 Nov 06	Page 98	Issue 7 Nov 06
Page 9	Issue 7 Nov 06	Page 54	Issue 7 Nov 06	Page 99	Issue 7 Nov 06
Page 10	Issue 7 Nov 06	Page 55	Issue 7 Nov 06	Page 100	Issue 7 Nov 06
Page 11	Issue 7 Nov 06	Page 56	Issue 7 Nov 06	Page 101	Issue 7 Nov 06
Page 12	Issue 7 Nov 06	Page 57	Issue 7 Nov 06	Page 102	Issue 7 Nov 06
Page 13	Issue 7 Nov 06	Page 58	Issue 7 Nov 06	Page 103	Issue 7 Nov 06
Page 14	Issue 7 Nov 06	Page 59	Issue 7 Nov 06	Page 104	Issue 7 Nov 06
Page 15	Issue 7 Nov 06	Page 60	Issue 7 Nov 06	Page 105	Issue 7 Nov 06
Page 16	Issue 7 Nov 06	Page 61	Issue 7 Nov 06	Page 106	Issue 7 Nov 06
Page 17	Issue 7 Nov 06	Page 62	Issue 7 Nov 06	Page 107	Issue 7 Nov 06
Page 18	Issue 7 Nov 06	Page 63	Issue 7 Nov 06	Page 108	Issue 7 Nov 06
Page 19	Issue 7 Nov 06	Page 64	Issue 7 Nov 06	Page 109	Issue 7 Nov 06
Page 20	Issue 7 Nov 06	Page 65	Issue 7 Nov 06	Page 110	Issue 7 Nov 06
Page 21	Issue 7 Nov 06	Page 66	Issue 7 Nov 06	Page 111	Issue 7 Nov 06
Page 22	Issue 7 Nov 06	Page 67	Issue 7 Nov 06	Page 112	Issue 7 Nov 06
Page 23	Issue 7 Nov 06	Page 68	Issue 7 Nov 06	Page 113	Issue 7 Nov 06
Page 24	Issue 7 Nov 06	Page 69	Issue 7 Nov 06	Page 114	Issue 7 Nov 06
Page 25	Issue 7 Nov 06	Page 70	Issue 7 Nov 06	Page 115	Issue 7 Nov 06
Page 26	Issue 7 Nov 06	Page 71	Issue 7 Nov 06	Page 116	Issue 7 Nov 06
Page 27	Issue 7 Nov 06	Page 72	Issue 7 Nov 06	Page 117	Issue 7 Nov 06
Page 28	Issue 7 Nov 06	Page 73	Issue 7 Nov 06	Page 118	Issue 7 Nov 06
Page 29	Issue 7 Nov 06	Page 74	Issue 7 Nov 06	Page 119	Issue 7 Nov 06
Page 30	Issue 7 Nov 06	Page 75	Issue 7 Nov 06	Page 120	Issue 7 Nov 06
Page 31	Issue 7 Nov 06	Page 76	Issue 7 Nov 06	Page 121	Issue 7 Nov 06
Page 32	Issue 7 Nov 06	Page 77	Issue 7 Nov 06	Page 122	Issue 7 Nov 06
Page 33	Issue 7 Nov 06	Page 78	Issue 7 Nov 06	Page 123	Issue 7 Nov 06
Page 34	Issue 7 Nov 06	Page 79	Issue 7 Nov 06	Page 124	Issue 7 Nov 06
Page 35	Issue 7 Nov 06	Page 80	Issue 7 Nov 06	Page 125	Issue 7 Nov 06
Page 36	Issue 7 Nov 06	Page 81	Issue 7 Nov 06	Page 126	Issue 7 Nov 06
Page 37	Issue 7 Nov 06	Page 82	Issue 7 Nov 06	Page 127	Issue 7 Nov 06
Page 38	Issue 7 Nov 06	Page 83	Issue 7 Nov 06	Page 128	Issue 7 Nov 06
Page 39	Issue 7 Nov 06	Page 84	Issue 7 Nov 06	Page 129	Issue 7 Nov 06
Page 40	Issue 7 Nov 06	Page 85	Issue 7 Nov 06	Page 130	Issue 7 Nov 06
Page 41	Issue 7 Nov 06	Page 86	Issue 7 Nov 06	Page 131	Issue 7 Nov 06
Page 42	Issue 7 Nov 06	Page 87	Issue 7 Nov 06	Page 132	Issue 7 Nov 06
Page 43	Issue 7 Nov 06	Page 88	Issue 7 Nov 06	Page 133	Issue 7 Nov 06
Page 44	Issue 7 Nov 06	Page 89	Issue 7 Nov 06	Page 134	Issue 7 Nov 06
Page 45	Issue 7 Nov 06	Page 90	Issue 7 Nov 06		

14.4 GLOSSARY OF TERMS

The following glossary is general to all the manufacturer's products and may thus contain terms which are not applicable to your particular unit. In particular, many of the terms are relevant only to configurable recorders.

Alarm	A function which is triggered when an <i>input signal</i> or a signal derived from it reaches a certain value (absolute or deviation alarms) or changes faster than a specified rate (rate-of-change alarms) or changes state (digital alarms). Once triggered, the alarm can initiate a <i>job list</i> , such as causing a <i>relay output</i> to change state, sounding a buzzer, changing chart speed etc.
Analogue input	An input which changes in a smooth (non-stepped) way (e.g. thermocouples, resistance thermometers).
Analogue output	An output from the recorder which is a scaled and linearized copy of an <i>analogue input</i> or <i>derived channel</i> . Also called retransmission output.
Attenuator	A resistive device which reduces the signal voltage by a known ratio (usually 100:1)
Break response	The recorder can detect an open circuit at its input terminals. As a part of the channel configuration, the instrument's response to an open circuit can be defined as 'None', 'Drive high' or 'Drive low'. If 'none' is selected the trace is allowed to drift according to what the input wiring is picking up (acting as an aerial). Drive high (low) causes the trace to be drawn at the extreme right (left) side of the chart.
Chart drive	A mechanical paper rotation. Includes chart hold-down tabs and a means for gripping the center of the chart to turn in at a specified rate..
Cold Junction Compensation	Also known by the abbreviation CJC. The current generated by a <i>thermocouple</i> (TC) junction depends on the temperature difference between the actual bonded junction (the hot junction), and the other (non-bonded) end of the conductors (the cold junction (CJ)). Thus, for any reading from a TC to be accurate, the temperature of the CJ must be taken into account. This can be done in three ways: Internal, External or Remote. <u>Internal</u> . The recorder has integral temperature detectors measuring the temperature near the terminal blocks (the cold junction for directly connected TCs). <u>External</u> . For remote TCs, the cold junction can be held at a known temperature. This temperature is entered (in degrees) as a part of the CJC configuration. <u>Remote</u> . For remote TCs, an auxiliary temperature detector can be used to measure the cold junction temperature. This detector is then connected to a separate input channel. This input channel number is entered as a part of the CJC configuration.
Communications	Most recorders now offer a 'Serial Communications' option to allow a computer (PC) to communicate directly with one or more recorders in order to <i>configure</i> them, or to read information from them regarding the <i>process variables</i> being measured.
Configuration	This is used as a verb to mean 'the process of telling your recorder what you want it to do', and as a noun to mean 'the way in which the recorder has been set up (or configured)'. Recorders fitted with <i>memory card</i> or <i>communications</i> options can save their configuration to the memory card or to the host computer. This ensures against loss, and also allows configurations to be copied from one recorder to another.
Counters	Counters can be incremented or decremented by digital/discrete inputs or by <i>job list</i> action. Counters can be preset. Each counter can have a set point which triggers a <i>job list</i> when the counter value passes through the set point either incrementing (High) or decrementing (Low).
Data acquisition	A general term describing the successful reading of an input signal. The term Data Acquisition Unit describes those units which are able to read input signals and act upon them (<i>alarms retransmission</i> maths functions etc) without necessarily having the facility of displaying or recording them.

14.4 GLOSSARY OF TERMS (Cont.)

Derived channel	A 'pseudo' channel which contains the results of maths pack operations so they can be traced on the chart, logged, used in other calculations etc.
Derived Variable (DV)	The result of one or more <i>input channel</i> or <i>derived channel</i> being acted upon by a <i>mathematical function</i> (e.g. Channel average).
Digital (discrete) input	An input which has only two states (on or off). Examples are switch inputs or voltage pulse inputs.
Event input	A discrete (switch) or digital (voltage level) input. When active, an event input can initiate a <i>job list</i> .
Hysteresis	When an <i>input signal</i> is 'hovering' near a <i>setpoint</i> , then an annoying and potentially damaging series of <i>alarms</i> can be generated, instead of just one alarm which can be acknowledged and the cause dealt with if necessary. To avoid this, a 'hysteresis' value can be entered in the alarm configuration, which effectively puts a dead band round the set point. For example an absolute high alarm with a set point of 100 and a hysteresis value of 10, would be triggered when the input signal value rose above 100, but would not re-trigger again until after the alarm had been 'cleared' by the process value falling below 90. An attempt to depict this example is given in the figure below.

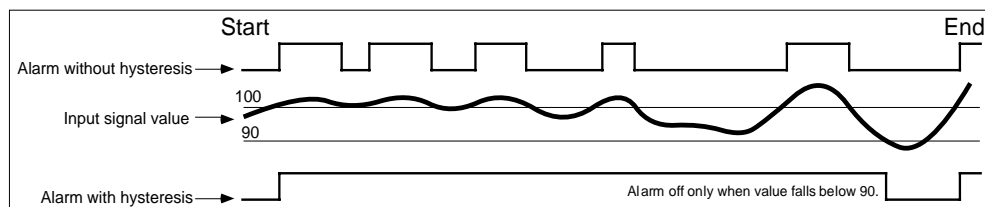

Input channel	An input circuit which accepts voltage, current or digital <i>input signals</i> from the user.
Input signal	A voltage, current or digital input applied to the recorder input circuits. See also Analogue input and Digital (discrete) input.
Job list	A set of actions to be carried out by the recorder, when the job list becomes active. Typical 'jobs' are to activate a <i>relay</i> , display a message, change chart speed etc.
Linearization table	Most <i>transducers</i> produce an output which is not directly proportional to the input. For example, the voltage output from a <i>thermocouple</i> does not vary linearly with the temperature it is exposed to. The recorder uses a 'look-up' table to find a temperature value for any mV input from a specified thermocouple type. Similar tables exist for other transducers such as <i>resistance thermometers</i> . In most modern instruments, the user can enter one or more tables of his/her own.
Log	Logging allows <i>process variable</i> values to be printed numerically in tabular form on the chart. Alternatively, logs can be sent to the <i>memory card</i> (if fitted).
Mathematical function	With the maths pack option(s) fitted, a number of mathematical functions become available to the user. For example, you may want to look at the difference between two <i>input signals</i> , in which case a simple Subtract function would be used. The resulting <i>Derived Variable</i> can be traced, using a <i>derived channel</i> , or could be used to trigger a <i>job list</i> if the difference between the two input signal became too great or too small, and so on. A complete list of functions is given below, but not all are available on all instruments.

14.4 GLOSSARY OF TERMS (Cont.)

Maths functions (Cont.)

Constant	Square root	Log base 10	Latching maximum	Switch
Copy	Channel average	Rate of change	Continuous maximum	High select
Add	Group average	Sample and hold	Polynomial	Low select
Subtract	Rolling average	Channel minimum	Relative humidity	Trace generator
Multiply	Exponent	Latching minimum	Linear mass flow	Stopwatch
Divide	Natural log	Continuous minimum	Square root mass flow	Time stamp
Modulus	10 ^X	Channel maximum	Zirconia probe	F value

Measured value	An umbrella term which means: the value of an <i>input channel</i> , <i>derived channel</i> , <i>totaliser</i> , <i>counter</i> , <i>timer</i> etc. measured in mathematical units as a proportion of the <i>span</i> . See also Process variable.
Memory card	Used to describe SRAM (Static Random Access Memory) solid state memory cards, or portable hard or floppy disks, used to record <i>configurations</i> , data etc. which can then be taken to a remote PC for further analysis, if required.
Multipoint recorder	This is used to describe recorders which have multiple pen <i>printheads</i> rather than individual pens to produce the <i>trace</i> on the chart. Each trace is made up of dots, produced by the printhead as it traverses across the chart at regular intervals. Advantages are that many more traces can be laid down on the chart, the traces can be annotated for identification and messages can be printed on the chart. Disadvantages are that fast transients may be missed at low chart speeds.
Operator interface	A term used to describe the controls (e.g. pushbuttons, keypads) and visual feedback (display) that are used to operate and configure the unit.
Paper transport system	This includes the <i>chart cassette</i> and the mechanical system, motors etc. needed to move the chart through the cassette. The paper transport system is often considered to be an integral part of the <i>writing system</i> .
Pen	A fiber-tipped disposable stylus with an integral ink reservoir. Used to draw (trace) the value of a single process variable on the chart in <i>continuous trace</i> recorders.
Printhead	This is a device which, together with a disposable multi-colour cartridge, allows multi-point recorders to mark the chart.
Process variable	An umbrella term which means: the value of an <i>input channel</i> , <i>derived channel</i> , <i>totaliser</i> , <i>counter</i> , <i>timer</i> etc. measured in engineering units (e.g. Degrees Celsius). See also Measured value.
Relay output	A set of contacts which changes state as a result of a <i>job list</i> being run. Relays are energised continuously except when 'in alarm', so that if power to the recorder fails they go into their 'alarm' state.
Resistance thermometer	Also known as a resistance temperature detector (RTD), a resistance thermometer is constructed of a material whose resistance varies in a known way on the temperature it is exposed to. The resistance variation is non-linear, but for any given type, this non-linearity is well known and invariable and is compensated for by <i>linearisation tables</i> in the recorder memory.
Retransmission output	See Analogue output.
Setpoint	Also known as 'threshold', this is the point at which an <i>alarm</i> becomes active or inactive. See also <i>hysteresis</i> .
Shunt	The input circuit of each recorder channel measures voltage signals. If current signals are connected to the recorder, a low value resistor must be placed across the inputs, to convert the current signal to Volts, according to Ohms law (Volts = Amps x Ohms). Thus, a 0 to 20 mA (0.02 Amps) signal applied across a 250 Ω resistor produces a voltage range of 0 to (0.02 x 250) Volts = 5 Volts. Such resistors are called 'Shunt resistors' or 'Shunts' for short, and are usually of very close tolerance.

14.4 GLOSSARY OF TERMS (Cont.)

Span	Span has two common meanings: the highest (or outer) grid of the chart, or the value given by (maximum value - minimum value). The two meanings are identical where the minimum value is zero.
Trace	The line produced on the chart or display screen showing the value of the <i>process variable</i> being measured.
Thermocouple	A junction of two dissimilar metals which produces a small voltage, the value of which depends on the temperature of the junction. The voltage varies in a non-linear way with temperature, but for any given type, this non-linearity is well known and invariable and is compensated for by <i>linearisation tables</i> in the recorder memory.
Threshold	See setpoint.
Timer	Timers carry out general timing functions, and can initiate <i>job lists</i> .
Totalizer	A mathematical function which allows flow rates (e.g. cubic feet per second) to be converted to actual quantities (e.g. cubic feet).
Transducer	A device which produces an electrical output proportional to temperature, flow rate, pressure, speed, position etc. Common transducers are potentiometers, <i>thermocouples</i> , <i>resistance thermometers (RTDs)</i> and flow meters.
Transmitter	Thermocouple wire (compensation wire) is expensive, and if the thermocouple is a long way from the measuring device, it is often cheaper to instal a 'transmitter' local to the thermocouple. This device converts the mV signal from the thermocouple to a mA signal which can then be wired to the recorder using normal copper wire. Transmitters can be self powered, or they may need power generated for them. Most recorders can be fitted with Transmitter Power Supplies as an option.
Writing system	A general term used to describe the mechanical means of moving <i>pens/printheads</i> across the chart width. The term often includes the paper transport system used to drive the chart.
Zero	Zero is generally taken to mean the value associated with the lowest (or center) grid line on the chart. Its actual value need not be zero, as long as it is less than the Span value.

ANNEX A TECHNICAL SPECIFICATION

INSTALLATION CATEGORY AND POLLUTION DEGREE

This product has been designed to conform to BS EN61010 installation category II and pollution degree 2. These are defined as follows:

INSTALLATION CATEGORY II

The rated impulse voltage for equipment on nominal 230V or lower ac line voltage is 2500V. I.E. The equipment is supplied from the fixed installation (IEC664)

POLLUTION DEGREE 2

Normally, only non-conductive pollution occurs. Occasionally, however, a temporary conductivity caused by condensation shall be expected.

A1 TECHNICAL SPECIFICATION (Recorder)

Board types (I/O)

Universal input board, 6-Changeover relay output board, 4-Channel analog output (retransmission) board

Options (See options manual)

Host Communications
 Memory Card
 Transmitter Power Supply
 Controllers (see also separate controller manual)
 Also Case Heater (not described)

Environmental Performance

Temperature limits 0 to 50°C operating (-20 to 50°C with case heater)
 With control, 0 to =40°C (depends on exact hardware configuration)
 Humidity limits 10 to 90% non-condensing
 Protection door and bezel - IP54 (optional IP65)
 Shock BS EN61010, corner drop test & BS EN60873 edge drop test
 Vibration BS EN60873 (10 to 60 Hz @ .07 mm displacement; 60 to 150 Hz @ 1g)
 Altitude (max) < 2000 metres

Physical

Bezel size 360 High by 380mm wide (Bezel centreline offset 5 mm right with respect to cutout centreline - see fig 1.2.1)
 Panel cutout dimensions 340.5 High by 345.5 wide (both - 0 + 2 mm)
 Depth behind bezel rear face 150 mm
 Weight average 7 Kg (15 lbs)
 Panel mounting Vertical + 5/- 30 degrees (where + means top or recorder towards operator - see figure 1.2.1)

Printing system

Pen type Four-nib cartridge
 Print resolution 0.2 mm
 Default trace colours
 (can be changed during configuration)

Channel	Colour	Channel	Colour
1	blue	4	black
2	red	5	blue/red
3	green	6	green/black

Printhead life 1.0 x 10⁶ dots per color - black has extra 50%
 Update rate 2 Hz (1 Hz when supplied with derived channels, timers, archiving or retransmission)
 Trace rate (maximum) 1 pass every 5 seconds
 Characters per line 39

Electromagnetic compatibility (EMC)

Emissions: BS EN50081-2
 Immunity: BS EN50082-2
 Electrical safety BS EN61010. Installation category II; Pollution degree 2

Paper transport

Type Stepper motor
 Chart speeds 1 to 960 hours per rev.
 Chart type 12 hour; 24 hour; 7-day, not timed
 Transport accuracy 0.25% single turn time accuracy

Power requirements

Line voltage Standard: 90 to 264V; 45 to 65 Hz
 Low voltage option: 20 to 53V ac (45 to 400 Hz) or dc (dc inrush-15A for 10ms @ 20V dc)
 Power (Max) 100VA, ac; 60W, dc
 Fuse type None
 Interrupt protection Standard: 40ms at 75% max. instrument load
 Enhanced: 120msec at 75% max. instrument load

A2 TECHNICAL SPECIFICATION (Input board)

General

Termination	Terminal block
Maximum number of inputs	Six.
Input ranges	$\pm 38\text{mV}$, $\pm 150\text{mV}$, $\pm 1\text{V}$, $\pm 10\text{V}$
Input types	DC Volts, dc millivolts, dc milliamps (with external shunt), thermocouple, 2 / 3-wire resistance temperature detector (RTD), Ohms, Contact closure (not channel 1) (Minimum contact closure = 500msec)
Input type mix	Freely configurable
Noise rejection (48 to 62 Hz)	Common mode: >130dB (channel - channel and channel - to - ground). Series mode: >60dB.
Maximum common mode voltage	250 Volts continuous
Maximum series mode voltage	45 mV peak at lowest range; 12 Volts peak at highest range.
Isolation (dc to 65 Hz; BS EN61010)	Installation category II; Pollution degree 2 300 V RMS or dc channel - to - channel (double insulation) and channel - to - ground (basic insulation)
Dielectric strength (BS EN61010)	Channel - to ground = 1350 Vac; Channel - to - channel = 2300 Vac (both 1 minute type tests).
Insulation resistance	>10 M Ω at 500 V dc
Input resistance	>10M Ω (38mV, 150mV, 1V); 68K Ω on 10V (always use mA input type for current inputs with shunts as it corrects for the 68K)
Overvoltage protection	42 V rms (terminal I to terminal V), 50 V rms (terminal V+ to terminals V- or I)
Sensor break detection	± 57 nA max.
Recognition time	500 msec.
Minimum break resistance	10 M Ω

DC Input ranges

Shunt/Attenuator	Resistor or voltage divider for terminal board mounting
Additional error due to shunt	0.1% of input
Additional error due to attenuator	0.2% of input

Performance @ 20 °C, $\pm 2^\circ\text{C}$

Range	Res- olution	Error at 20 °C		Temperature coefficient (per °C)
		Typical	Max	
± 38 mV	1.4 μV	Typical	0.035% input + 0.030% range	37 ppm input + 1.03 ppm range
		Max	0.085% input + 0.051% range	80 ppm input + 18.6 ppm range
± 150 mV	5.5 μV	Typical	0.035% input + 0.027% range	35 ppm input + 0.52 ppm range
		Max	0.084% input + 0.038% range	80 ppm input + 7.8 ppm range
± 1 V	37 μV	Typical	0.035% input + 0.024% range	35 ppm input + 0.16 ppm range
		Max	0.084% input + 0.029% range	80 ppm input + 1.6 ppm range
± 10 V	370 μV	Typical	0.076% input + 0.024% range	76 ppm input + 0.35 ppm range
		Max	0.275% input + 0.030% range	272 ppm input + 3.5 ppm range

(Continued)

A2 TECHNICAL SPECIFICATION (Input board) (Cont.)

Resistance/RTD inputs

Ranges (including lead resistance)	0 to 150 Ω, 0 to 600 Ω, 0 to 6kΩ
Influence of lead resistance	Error = negligible (3-wire); Mismatch = 1 Ω/Ω (3-wire)
Temperature scale	ITS90
Resolution and accuracy @ 20 °C, ±2 °C	

Range (Ω)	Res-olution	Error at 20 °C		Temperature coefficient (per °C)
		Typical	Max	
0 to 150	5mΩ	Typical	0.030% input + 0.047% range	20 ppm input + 2.04 ppm range
		Max	0.045% input + 0.141% range	35 ppm input + 36.6 ppm range
0 to 600	22mΩ	Typical	0.030% input + 0.036% range	20 ppm input + 0.97 ppm range
		Max	0.045% input + 0.069% range	35 ppm input + 14.6 ppm range
0 to 6k	148mΩ	Typical	0.034% input + 0.026% range	20 ppm input + 0.19 ppm range
		Max	0.049% input + 0.032% range	35 ppm input + 1.9 ppm range

RTD types, ranges and accuracies

RTD Type	Overall range (°C)	Standard	Max linearisation error
Cu10	-20 to + 400	General Electric Co.	0.02 °C
JPT100	-220 to + 630	JIS C1604:1989	0.01 °C
Ni100	- 60 to + 250	DIN43760:1987	0.01 °C
Ni120	-50 to + 170	DIN43760:1987	0.01 °C
Pt100	-200 to + 850	IEC 751	0.01 °C
Pt100A	-200 to + 600	Eurotherm Recorders SA	0.09 °C
Pt1000	-200 to + 850	IEC 751	0.01 °C

Thermocouple data

Temperature scale	ITS90
Bias current	1.7nA on ±38mV range, 8nA on all other ranges
Cold junction types	Off, internal, external, remote
CJ error	1°C max; instrument at 25 °C
CJ rejection ratio	50:1 minimum
Remote CJ	Via any user-defined input channel
Upscale / downscale drive	Set on a PER RECORDER basis. All channels must be set (high or off) OR (low or off)
Types and ranges	See table

T/C Type	Overall range (°C)	Standard	Max linearisation error
B	0 to + 1820	IEC 584.1	0 to 400°C: 1.7°C 400 to 1820°C: 0.03°C
C	0 to + 2300	Hoskins	0.12°C
D	0 to + 2495	Hoskins	0.08°C
E	- 270 to + 1000	IEC 584.1	0.03°C
G2	0 to + 2315	Hoskins	0.07°C
J	- 210 to + 1200	IEC 584.1	0.02°C
K	- 270 to + 1372	IEC 584.1	0.04°C
L	- 200 to + 900	DIN43700:1985 (To IPTS68)	0.20°C
N	- 270 to + 1300	IEC 584.1	0.04°C
R	- 50 to + 1768	IEC 584.1	0.04°C
S	- 50 to + 1768	IEC 584.1	0.04°C
T	- 270 to + 400	IEC 584.1	0.02°C
U	- 200 to + 600	DIN 43710:1985	0.08°C
Ni/NiMo	0 to + 1406	Ipsen	0.14°C
Platinel	0 to + 1370	Engelhard	0.02°C

INDEX

Symbols

10 to the power (Maths function) 71

A

Absolute alarms 48
 Adaptive recording 42
 Add (Maths function) 70
 Adjust
 Chart 32
 Input 59
 Alarm
 Average 49
 Change value 49
 Deviation value entry 49
 Dwell 49
 Enable 47
 Hysteresis 49
 Indication 19
 Jobs 49
 Latched 47
 Off/On 47
 Operator setup page 30
 Reference value entry 49
 Summary page 29
 Threshold (setpoint) entry 49
 Trigger 47
 Types 48 to 49
 Unlatched 47
 Alarms
 Relay option 63
 Analog output option 65
 Archive configuration 108
 Archive file names 112
 Archive to memory card 107
 Average (Rate of Change alarms) 49

B

Break Response 45

C

Chanel minimum (maths function) 72
 Change value (Rate of Change alarms) 49
 Changing
 Chart 16
 Print cartridge 17
 Channel
 Basic configuration 22 to 27
 Break Response 45
 CJC type selection 45
 Damping 45
 Display 18
 Hold 19
 Input range 43
 Input type 43
 Input units 43
 Line thickening 50

Channel (Cont.)

Linearisation types 44
 N° of decimal places 45
 Open/closed text 46
 Scaling 45
 Selection for display 53
 Shunt value 43
 Span A/B setting 50
 Tag 46
 Test waveforms 46
 Trace colour selection 50
 Trace on/off 50
 Value format 45
 Channel average (Maths function) 71
 Channel maximum (maths function) 72
 Character set 35
 Chart
 Adjust 32
 Align with time datum 28
 Calibration 32
 Configuration 41
 Replacement 16
 Span setting 50
 Speed
 Printing on the chart 42
 User 41
 CJC
 Remote channel N° 40
 Type selection 45
 Clock configuration 53
 Colour of traces 50
 Configuration
 Alarms 47 to 49
 Channel 43 to 51
 Chart 41 to 42
 Clock 53
 Entry to 21, 31
 Error messages 121
 Example 21 to 27
 Group 52
 Instrument 40
 Internal events 55
 Log interval 42
 Password 40
 Return to default 60
 Save/Restore 106
 Techniques 39
 Transfer
 Configuration 57
 Constant (maths function) 70
 Controller option 92
 Copy (maths function) 70
 COSHH data
 Batteries 120
 Printheads 120
 Counters 88
 Custom Linearisation 95

D

Damping 45
 Data logging 107
 Date
 Format 53
 Inclusion in messages 54
 Printing on the chart 42
 Setting 53
 View 30
 Decimal place position 45
 Default Configuration 60
 Derived variables 69
 Deviation alarms 48
 Deviation value entry 49
 Display
 Group 53
 Interpretation 18
 Divide (Maths function) 70
 Drive hi/lo 45
 Dump scales 29
 DV Group cont max (maths function) 72
 DV Group cont min (maths function) 72
 DV Group latch max (maths function) 72
 DV Group latch min (maths function) 72
 Dwell (alarms) 49

E

e to the power (maths function) 71
 Embedded sequences 54
 Entering
 Configuration menus 21
 Numeric values 22
 Text 35
 Error messages 121
 Events 55

F

F Value (maths function) 73
 Factory settings (return to) 60

G

Group
 Configuration 52
 Display 53
 Log 52
 Group average (Maths function) 71

H

High select (maths function) 78
 How to
 Change the chart 16
 Change the print cartridge 17
 Hysteresis 49

I

Input
 Adjust 59
 Range entry 43
 Type selection 43
 Units selection 43
 Input board
 Specification 129 to 130
 Installation
 Chart 16
 Instrument tag 40
 Internal Events 55
 Invalid configuration message 121

J

Jobs 37
 Maths pack 69
 Memory card 108

L

Language selection 40
 Line thickening 50
 Linearisation tables 44
 Log
 Contents 52
 Group 52
 Initiation 29
 Interval 42
 Log base 10 (Maths function) 71
 Low select (maths function) 78

M

Mass Flow (maths function)
 Linear 74
 Square root 76
 Maths pack
 Menu overview 83
 Option 69
 Memory card option 103
 Message
 Configuration 54
 Printing 42
 Modbus protocol 99
 Modulus (Maths function) 70
 Multiply (Maths function) 70

N

Natural log (Maths function) 71

O

Open/closed text	46
Operation	
Detailed	27 to 32
Operator	
Access to configuration	58
Menus	
Alarm setup page	30
Chart	27
Clock	30
Configuration	31
Dump scales	29
Log	29
System error	30
Top level	27
Oxygen concentration	77
Oxygen correction (maths function)	79
Oxygen potential	78

P

Password	
Default	22, 31
Entry of new	40
Percentile maths function	80
Power-up message	18
Print cartridge replacement	17
Printhead	
Park	17
Printing	
Logs	29
Scales	29
Process value	
Display	18
Inclusion in messages	54
PV formats (maths functions)	81

Q

Quick scale print	29
-------------------------	----

R

Rate of change (maths function)	72
Rate-of-change alarms	49
Recorder	
Installation	
Mechanical	11
Labelling symbols	10
Specification	128 to 130
Reference value entry	49
Relative humidity (maths function)	73
Relay option	63
Remote CJ channel	40
Replacing	
Chart	16
Retransmission option	65
Rolling average (Maths function)	71

S

Safety notes	10
Sample and hold (maths function)	72
Scale	
Printing on the chart	42
Scaling	45
Serial communications option	96
Shunt value entry	43
Span setting	50
Specification	
Analogue outputs	65
Controllers	94
Input board	129 to 130
Recorder	128 to 130
Relay	63
Serial Communications board	96
Transmitter power supply	116
Square root (Maths function)	71
Static precautions	9
Stopwatch (maths function)	78
Subtract (Maths function)	70
Switch (maths function)	78
Symbols (Recorder labelling)	10
System error	31

T

Tag	
Channel	46
Instrument	40
Termination and biasing	96 to 97
Test waveform selection	46
Text entry	35
Third order polynomial (maths function)	72
Time	
Inclusion in messages	54
Printing on the chart	42
Setting	53
View	30
Time stamp (maths function)	79
Timers	90
Totalisers	85
Trace	
Colour	50
On/off	50
Transfer configuration	57
Transmitter power supply	116

U

User chart speed	41
------------------------	----

V

Value format	45
--------------------	----

X

XMODEM transfer	102
-----------------------	-----

Z

Zirconia probe maths function	77
-------------------------------------	----

This page is deliberately left blank

Inter-Company sales and service locations

AUSTRALIA Sydney

Eurotherm Pty. Ltd.
Telephone (+61 2) 9838 0099
Fax (+61 2) 9838 9288
E-mail info.au@eurotherm.com

AUSTRIA Vienna

Eurotherm GmbH
Telephone (+43 1) 7987601
Fax (+43 1) 7987605
E-mail info.at@eurotherm.com

BELGIUM & LUXEMBURG Moha

Eurotherm S.A./N.V.
Telephone (+32) 85 274080
Fax (+32) 85 274081
E-mail info.be@eurotherm.com

BRAZIL Campinas-SP

Eurotherm Ltda.
Telephone (+5519) 3707 5333
Fax (+5519) 3707 5345
E-mail info.br@eurotherm.com

DENMARK Copenhagen

Eurotherm Danmark AS
Telephone (+45 70) 234670
Fax (+45 70) 234660
E-mail info.dk@eurotherm.com

FINLAND Abo

Eurotherm Finland
Telephone (+358) 22506030
Fax (+358) 22503201
E-mail info.fi@eurotherm.com

FRANCE Lyon

Eurotherm Automation SA
Telephone (+33 478) 664500
Fax (+33 478) 352490
E-mail info.fr@eurotherm.com

GERMANY Limburg

Eurotherm Deutschland GmbH
Telephone (+49 6431) 2980
Fax (+49 6431) 298119
E-mail info.de@eurotherm.com

HONG KONG & CHINA

Eurotherm Limited North Point
Telephone (+85 2) 28733826
Fax (+85 2) 28700148
E-mail info.hk@eurotherm.com

Guangzhou Office

Telephone (+86 20) 8755 5099
Fax (+86 20) 8755 5831
E-mail info.cn@eurotherm.com

Beijing Office

Telephone (+86 10) 6567 8506
Fax (+86 10) 6567 8509
E-mail info.cn@eurotherm.com

Shanghai Office

Telephone (+86 21) 6145 1188
Fax (+86 21) 6145 1187
E-mail info.cn@eurotherm.com

INDIA Chennai

Eurotherm India Limited
Telephone (+9144) 2496 1129
Fax (+9144) 2496 1831
E-mail info.in@eurotherm.com

IRELAND Dublin

Eurotherm Ireland Limited
Telephone (+353 1) 4691800
Fax (+353 1) 4691300
E-mail info.ie@eurotherm.com

ITALY Como

Eurotherm S.r.l.
Telephone (+39 31) 975111
Fax (+39 31) 977512
E-mail info.it@eurotherm.com

KOREA Seoul

Eurotherm Korea Limited
Telephone (+82 31) 2738507
Fax (+82 31) 2738508
E-mail info.kr@eurotherm.com

NETHERLANDS Alphen a/d Rijn

Eurotherm B.V.
Telephone (+31 172) 411752
Fax (+31 172) 417260
E-mail info.nl@eurotherm.com

NORWAY Oslo

Eurotherm A/S
Telephone (+47 67) 592170
Fax (+47 67) 118301
E-mail info.no@eurotherm.com

POLAND Katowice

Invensys Eurotherm Sp z o.o
Telephone (+48 32) 218 5100
Fax (+48 32) 217 7171
E-mail info.pl@eurotherm.com

SPAIN Madrid

Eurotherm España SA
Telephone (+34 91) 661 6001
Fax (+34 91) 661 9093
E-mail info.es@eurotherm.com

SWEDEN Malmo

Eurotherm AB
Telephone (+46 40) 384500
Fax (+46 40) 384545
E-mail info.se@eurotherm.com

SWITZERLAND Wollerau

Eurotherm Produkte (Schweiz) AG
Telephone (+41 44) 787 1040
Fax (+41 44) 787 1044
E-mail info.ch@eurotherm.com

UNITED KINGDOM Worthing

Eurotherm Limited
Telephone (+44 1903) 268500
Fax (+44 1903) 265982
E-mail info.uk@eurotherm.com
Web www.eurotherm.co.uk

U.S.A Leesburg VA

Eurotherm Inc.
Telephone (+1 703) 443 0000
Fax (+1 703) 669 1300
E-mail info.us@eurotherm.com
Web www.eurotherm.com

ED52



Invensys

EUROTHERM

EUROTHERM LIMITED

Faraday Close, Durrington, Worthing, West Sussex, BN13 3PL
Telephone: +44 (0)1903 268500 Facsimile: +44 (0)1903 265982

e-mail: info.uk@eurotherm.com

Website: <http://www.eurotherm.co.uk>

